

T310



DTSD1352

Installation and operation instruction V2.00

ACREL Co.,Ltd

Declare

The copyright is the property of Acrel. Any information in any paragraph or section cannot be extracted, copied or otherwise reproduced or propagated. Otherwise offenders shall take all consequences.

All rights are reserved.

Acrel reserves the right to modify the product specifications herein without notification. Please consult the local agent about the latest specifications before placing a purchase order.

Content

1	General	1
2	Type description	1
3	Function description	1
4	Technical parameter	2
5	Outline	3
6	Wiring and installing	3
7	Function description	8
8	Operation and display	9
9	Communication description	12

1 General

DTSD1352 is a smart meter designed for power supply system, industrial and mining enterprises and utilities to calculate the electricity consumption and manage the electric demand. It features the high precision, small size and simple installation. It integrates the measurement of all electrical parameters with the comprehensive electricity metering and management provides various data on previous 12 months, checks the 31st harmonic content and the total harmonic content, realizes the remote communication and the remote control with switching input and relay output and boasts the alarm output. It is fitted with RS485 communication port and adapted to MODBUS-RTU. DTSD1352 can be used in all kinds of control systems, SCADA systems and energy management systems.

2 Type description

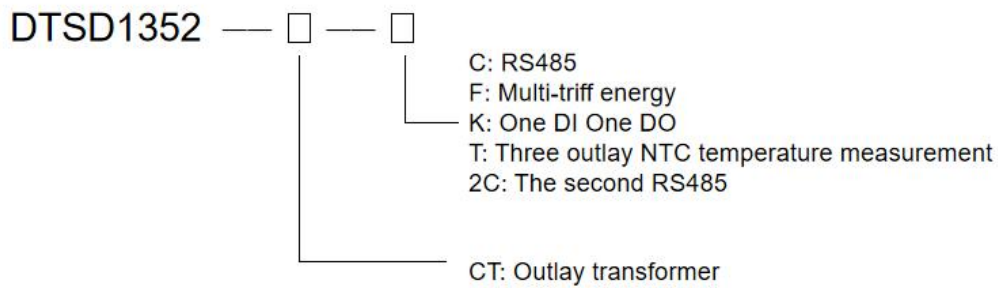

3 Function description

Function	Function description	Function provide
Measurement of kWh	Active kWh (positive and negative)	■
	Reactive kWh (positive and negative)	■
	A, B, C phase positive active kWh	■
Measurement of electrical parameters	U、IP、Q、S、PF、F	■
		■
Measurement of	2~31 ST Voltage and current harmonic	■
LCD Display	8 bits section LCD display, background light	■
Key programming	4 keys to communication and set parameters	■
Pulse output	Active pulse output	■
	Reactive pulse output	<input type="checkbox"/> Note 1
	Clock pulse output	<input type="checkbox"/> Note 1
Multi-tariff and functions	Active switch input	<input type="checkbox"/> Note2
	Switch output	<input type="checkbox"/> Note 2
	Adapt 4 time zones, 4 time interval lists, 14 time interval by day and 4 tariff rates	<input type="checkbox"/>

	Max demanded kWh and time happened	<input type="checkbox"/>
	Frozen data on last 48 months, last 90days	<input type="checkbox"/>
	Date, time	<input type="checkbox"/>
Communication	Infrared communication	■
	The first communication path: Communication interface: RS485, Communication protocol: MODBUS-RTU	<input type="checkbox"/>
	The second communication path: Communication interface: RS485, Communication protocol: MODBUS-RTU	<input type="checkbox"/> Note 2
Temperature measurement	Support 3 outlay NTC temperature	<input type="checkbox"/> Note 3

“■” means standard, “□” means optional.

Note:

1: Reactive pulse output, clock pulse output and switching output: Choose one of these three.

2: Active switching, the second communication path: Choose one of these two.

3: Both 1 and 2 cannot be chosen while choosing temperature measurement.

4 Technical parameter

Specification		3 phase 3 wires	3 phase 4 wires
Voltage	Reference voltage	3×100V、 3×380V	3×57.7/100V、 3×220/380V
	Input voltage range	U _{max} : 1.3U _N	
	Consumption	<10VA(Single phase)	
	Impedance	>2MΩ	
	Accuracy class	Error±0.2%	
Current	Input current	3×1(6)A, 3×1(6)A(Outlay transformer), 3×10(80)A, 3×10(100)A(Outlay transformer)	
	Consumption	<1VA(Single phase rated current)	
	Accuracy class	Error±0.2%	
Power		Active, reactive, apparent power, error±0.5%	
Frequency		45~65Hz, Error±0.2%	
Temperature		-40℃~99℃	
Energy		Active energy(Accuracy class:0.5, 1), reactive energy(Accuracy class 2)	
Clock		≤0.5s/d	
Energy pulse output		1 active optocoupler output, 1 reactive optocoupler output	
Switching output		1 Switching output, Maximum allowed voltage: DC/AC 220V	
Switching input		1 optocoupler input,Maximum allowed voltage: DC/AC 220V	
Width of pulse		80±20ms	
Pulse constant		6400imp/kWh,400imp/kWh(Correspond with the basic current)	
Interface and communication		RS485: Modbus RTU	
Range of communication address		Modbus RTU:1~ 247;	

Baud rate	1200bps~19200bps
Relative temperature	-25°C~+55°C
Relative humidity	≤95%(No condensation)

5 Dimension drawings

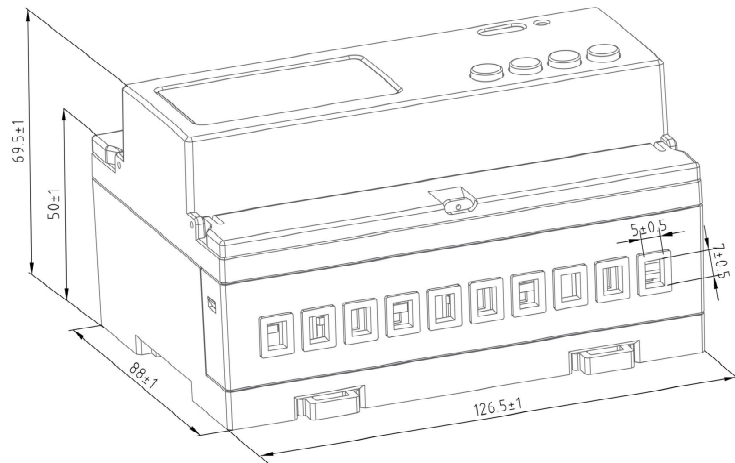

Fig1 connect via CT

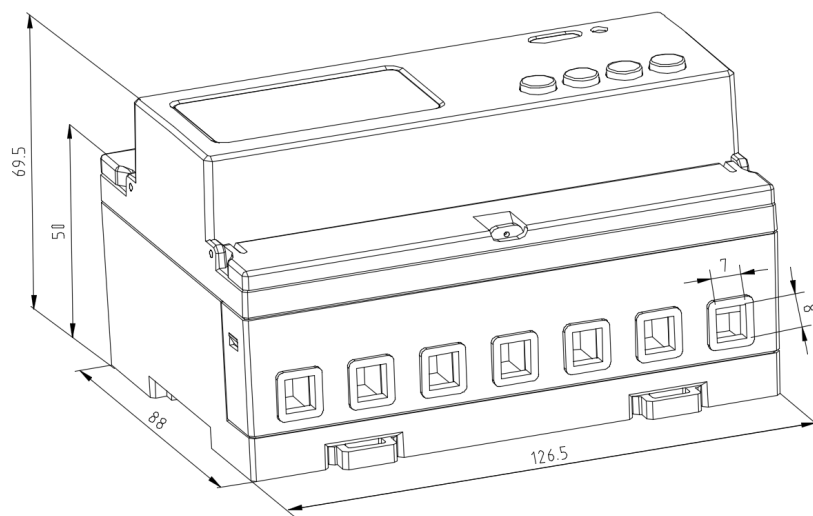

Fig2 direct connect

Note: The torque of direct connect should not be greater than 4.0N·m, and the torque of connect via CT should not be greater than 2.0N·m.

6 Wiring and installing

6.1 Wiring instructions

The DTSD1352-CT uses three-phase four-wire transcurrent transformer access,

three-phase three-wire transcurrent transformer access, three-phase four-wire via voltage and current transformer access, and three-phase three-wire transcurrent voltage transformer access. When using three-phase and three-wire access, the instrument needs to be modified by pressing the button or the corresponding debugging software.

Remark:

1. DTSD1352-CT external transformer is red and white two wires, red instrument IA*, IB*, IC*, white instrument IA, IB, ;

2. The DTSD1352-CT uses its own mA class transformer, and it is strictly forbidden to access ordinary 5A or 1A output transformers, otherwise it will cause damage to the instrument;

3. DTSD1352-CT When wiring, the transformer terminals are prohibited from shorting and grounding, otherwise it will lead to inaccurate metering or instrument damage;

4. When the DTSD1352-CT is used to measure the secondary line of the field transformer, the instrument's own transformer should be kept at a distance (greater than 30cm) from the field primary side transformer to avoid interference.

6.2 Wiring sample of voltage and current

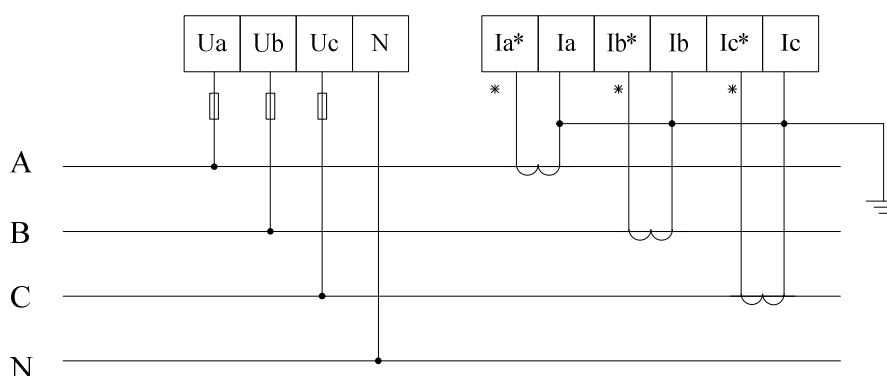

Fig 3 Three phase four lines connect via CT

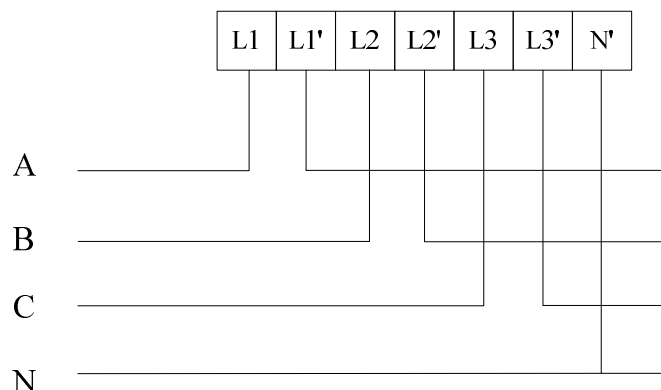

Fig 4 Three phase four lines direct connect

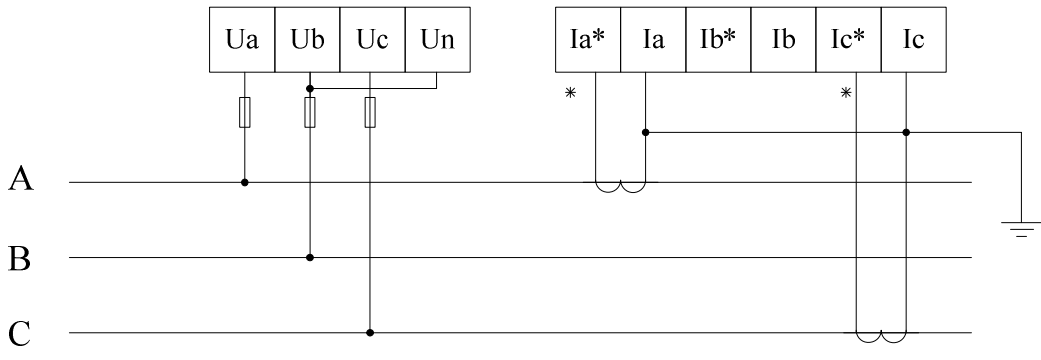

Fig 5 Three phase three lines connect via CT

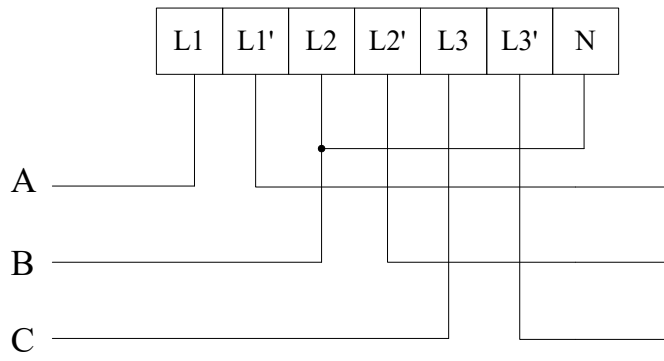

Fig 6 Three phase three lines direct connect

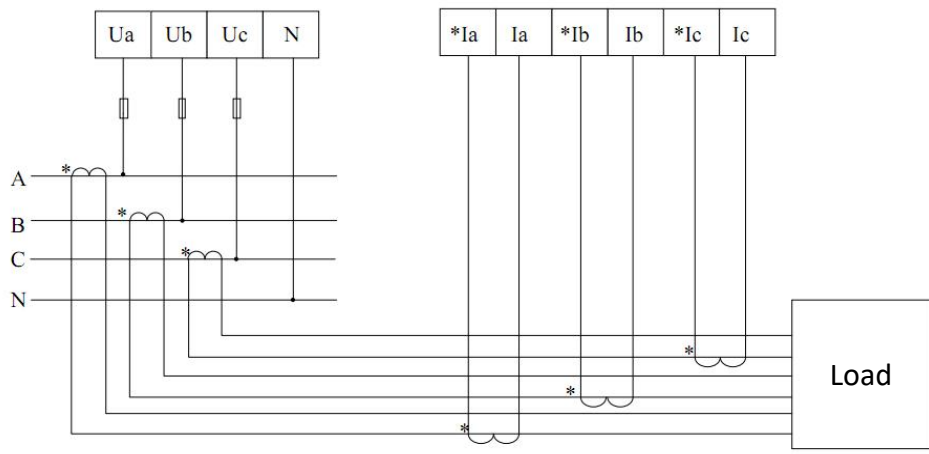

Fig 7 Three phase four lines, 3CT

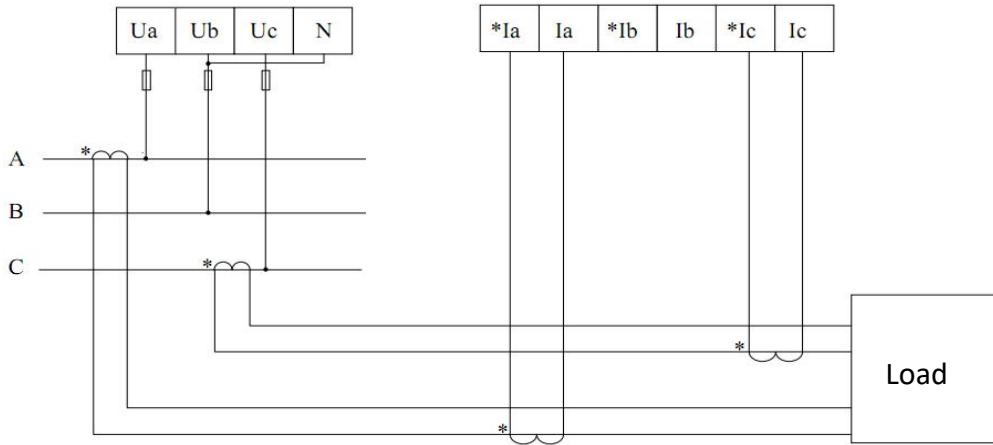

Fig 8 Three phase three lines, 2CT

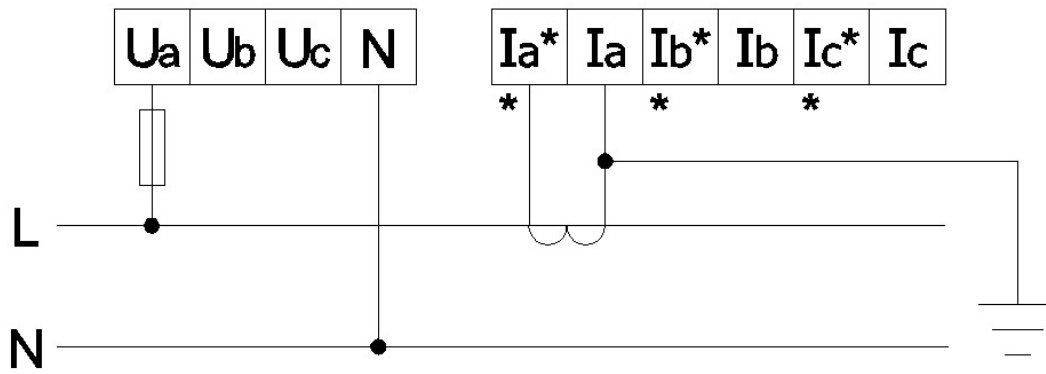

Fig 9 Single phase connect via CT

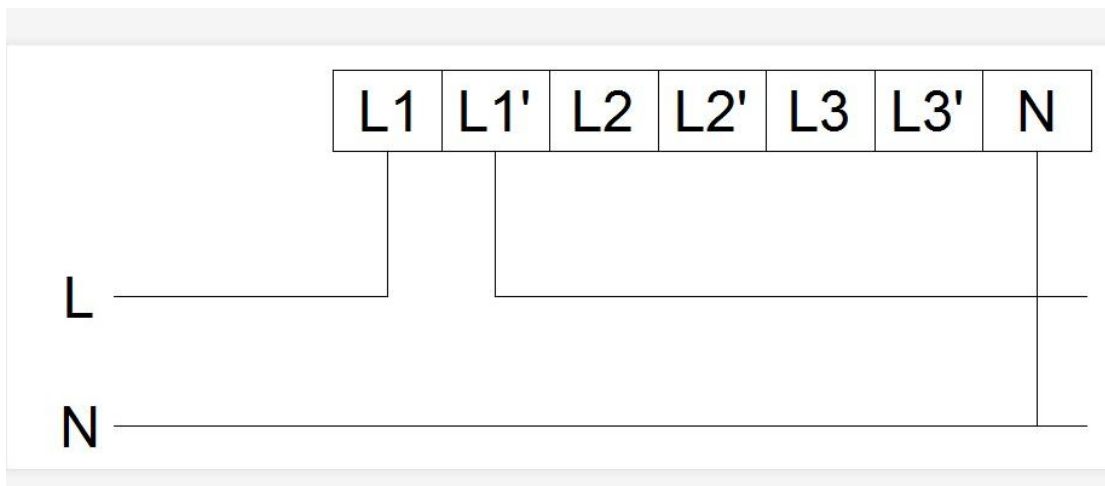

Fig 10 Single phase direct connect

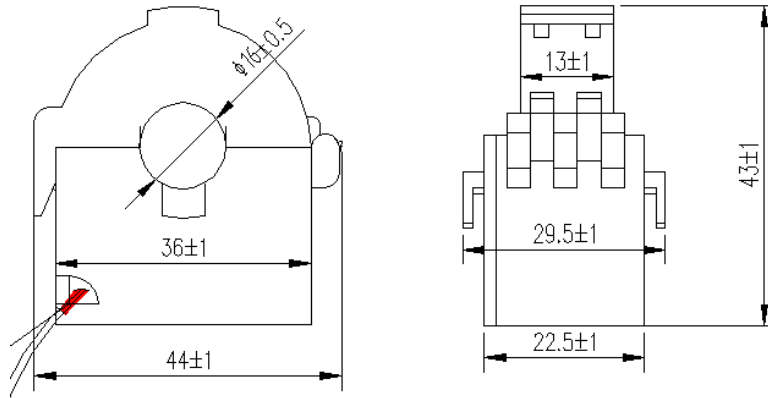

Fig 11 Outline of transformer

Note: The method of wiring is: input downward and output downward.

6.3 Switching input, output, NTC temperature terminals

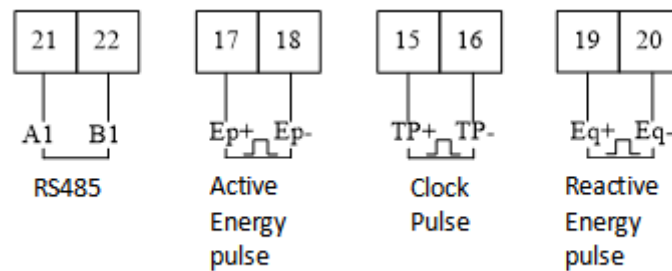

Fig 12 Communication, pulse connection

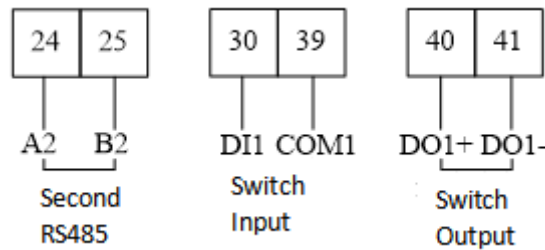

Fig 13 Communication, pulse connection

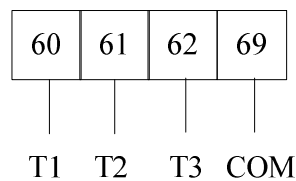

Fig 12 Outlay NTC temperature measurement

Switching output is relay output, can achieve the remote-control and alarm output.

The switch input adapts the method of on-off signal input and powered by outer power supply. It can be gotten by meter when there is a change of on or off via a switching input module. The parameter of switching input can not only get and show the state of local switching information but also achieve the communication via RS485, which called “remote information” function.

Note: (17-18) are active energy pulse, (60,61,62,69) are NTC temperature measurement port,

(15,16) are clock pulse, (19,20) are reactive energy pulse, (40,41) are switch output and multiplex with (60,61), (24,25) are 2 path of communication, (30, 39) are switch input and multiplex with (62,69).

7 Function description

7.1 Measurement

The meter can measure all electrical parameters such as voltage, current, active power, reactive power, apparent power, power factor, frequency, 31st harmonic and total harmonic. The value format of voltage, current, frequency and power are listed as below.

Example: $U = 220.1V$, $f = 49.98Hz$, $I = 1.99A$, $P = 0.439kW$

7.2 Calculating

The meter can calculate the current active energy, forward active energy, reversing active energy, forward reactive energy and reversing reactive energy.

7.3 Timing

The meter has 2 time lists, and can be divided into 4 time zones per year. Each time list can be divided into 8 time periods and 4 tariff (F1、F2、F3、F4). The main purpose of multi-tariff is promote the energy efficiency and economic benefits.

7.4 Demand

There are some definitions on demand:

Demand	The average power in the demand cycle.
Maximum demand	The maximum value of demand in a period of time.
Slip time	A recurrence method to measure the demand from any time point during a period shorter than the demand period. The demand measured by this means is called sliding demand. The recurrence time is sliding window time.
Demand cycle	The time period between two same average value of demand.

The default demand cycle is 15 minutes, slip time is 1 minute.

The meter can measure 4 kinds of maximum demand: forward active, reversing active, inductance performance reactive, capacitance performance reactive maximum demand and the occur time.

7.5 History data statistics

The meter can record last 48 months or last 90 days history energy in each tariff.

7.6 Switching input and output

The switch input adapts the method of on-off signal input and powered by outer power supply. It can be gotten by meter when there is a change of on or off via a switching input module. The parameter of switching input can not only get and show the state of local switching information





but also achieve the communication via RS485, which called “remote information” function.

7.7 Temperature measurement

The meter support three path of outlay NTC temperature measurement, the range of temperature is -40°C~99°C.



8 Operation and display

8.1 Key function description

Key symbol	Key name	Function
	Menu	Enter/quit menu
	Voltage and current, up	Check the voltage and current Leftward and change flash in programming menu
	Power, down	Check the power Rightward and change the value on flash
	Energy, enter	Check the energy Enter in programming menu

8.2 Display menu

The meter will show the forward active energy after powering. The customers can change the information showing by pressing the keys. The menu description is listed as below:

	Voltage on A, B, C phase, Current on A, B, C phase, Frequency, Date, Time, Address, Version, Test on display
	Total active/reactive/apparent power and on A, B, C phase, Total power factor and on A, B, C phase, Forward/reversing active/reactive maximum demand
	Total forward/reserving active/reactive energy, forward/reserving active/reactive spike/peak/flat/valley energy, forward active energy on A, B, C phase.

Note:

1 All the display menus above are in the model of ADL3000-EF three phases four lines with multi-tariff rate function and can be changed by the keys.

2 There will not be power or power factor on each phase and will only show total power and power factor (Active, reactive, apparent) under the three phase three lines.

3 There will not be date, time, maximum demand and energy by time without the function of multi-tariff rate.



Current forward active energy 12.34kWh



Current reversing active energy 12.34kWh



Current forward reactive energy 12.34kWh



Current forward active spike energy 12.34kWh



Current total power is 1.234kW



Current forward active demand is 1.234kW



Voltage on A phase is 123.4V



Current on A phase is 12.34A



Temperature on T1 is 25.5 cent degree







Temperature on T2 is 25.5 cent degree



Temperature on T3 is 25.5 cent degree

Note: There are parts of the display function, and other menus are familiar with the example above. The customers can understand the meaning refer to the above examples.

8.3 Key Menu

Press  at any main menu and get in “PASS” interface, and then press  show “0000”, and enter the code. If you enter a wrong code, it will show “fail” and back to main menu; and if you enter a right code, you can set the parameter. After setting the parameter and press , it will show “save” and save the change by pressing  in “yes” interface and quit without save by pressing  in “no” interface.

8.4 Data settings

Num	First menu		Second menu		
	Symbol	Mean	Symbol	Mean	Range
1	BUS	Communicati on settings	ADDR	Address setting	1-247
			Baud	Baud rate	19200、 9600、 4800、 2400、 1200
			Parity	Parity	None、 Even
2	SyS	System settings	PL	Network	3P4L: 3 phase 4 lines 3P3L: 3 phase 3 lines

			EF.E	Multi-tariff rate	EF: Multi-tariff rate E: No multi-tariff rate
			Code	Code setting	1-9999
			LED	Time of light	1-9999
3	In.	Transformer settings	Pt	Voltage transformer	1-9999
			Ct	Current transformer	1-9999

Note: Customers can choose None or Even under Modbus protocol.

9 Communication description

The meter adapts MODBUS-RTU protocol, and the baud rate can be chosen from 1200bps、2400 bps、 4800 bps、 9600bps and 19200 bps. The parity is None.

The meter needs shielded twisted pair conductors to connect. Customers should consider the whole network's parameters such like communication wire's length, the direction, communication transformer and network cover range, etc.

Note:

Wiring should follow the wiring requirements;

Connect all the meter in the RS485 net work even some do not need to communication, which is benefit for error checking and testing;

Use two color wires in connecting wires and all the A port use the same color.

No longer than 1200 meters of RS485 bus line.

9.1 ADDR list

MODBUS-RTU protocol has 03H and 10H command to read and write registers respectively. The following chart is registers' address list:

Address	Variable	Length	R/W	Notes
0000H	Current total active energy	4	R	E=data*PT*CT*0.01 Data: data read in the communication, Pt: voltage ratio CT: current ratio Unit:kWh (active) kVarh(reactive) This formula is applicable to all electric energy values.
0002H	Current spike total active energy	4	R	
0004H	Current peak total active energy	4	R	
0006H	Current flat total active energy	4	R	
0008H	Current valley total active energy	4	R	
000AH	Current forward active total energy	4	R	

000CH	Current forward active spike energy	4	R
000EH	Current forward active peak energy	4	R
0010H	Current forward active flat energy	4	R
0012H	Current forward active valley energy	4	R
0014H	Current reversing active total energy	4	R
0016H	Current reversing active spike energy	4	R
0018H	Current reversing Active peak energy	4	R
001AH	Current reversing active flat energy	4	R
001CH	Current reversing Active valley energy	4	R
001EH	Current total reactive energy	4	R
0020H	Current total reactive spike energy	4	R
0022H	Current total reactive peak energy	4	R
0024H	Current total reactive flat energy	4	R
0026H	Current total reactive valley energy	4	R
0028H	Current forward reactive total energy	4	R
002AH	Current forward reactive spike energy	4	R
002CH	Current forward reactive peak energy	4	R
002EH	Current forward reactive flat energy	4	R
0030H	Current forward reactive valley energy	4	R
0032H	Current reversing reactive total energy	4	R
0034H	Current reversing reactive spike energy	4	R

0036H	Current reversing reactive peak energy	4	R	
0038H	Current reversing reactive flat energy	4	R	
003AH	Current reversing reactive valley energy	4	R	
003CH	Time: second, minute	2	R/W	
003DH	Time: hour, day	2	R/W	
003EH	Time: month, year	2	R/W	
003FH high byte	First communication path: Address	1	R/W	1~247
003FH low byte	First communication path: Baud rate	1	R/W	1: 9600pbs 2: 4800pbs 3: 2400pbs 4: 1200pbs
0040H	Pulse constant	2	R	
0041H	Time table number of the first time zone Time zone 1 start date: day	2	R/W	Time table No.: 1: the first time table 2: the second time table
0042H	Time zone 1 start date: month Time table number of the second time zone	2	R/W	
0043H	Time zone 2 start date: day Time zone 2 start date: month	2	R/W	
0044H	Time table number of the third time zone Time zone 3 start date: day	2	R/W	
0045H	Time zone 3 start date: month Time table number of the fourth time zone	2	R/W	
0046H	Time zone 4 start date: day Time zone 4 start date: month	2	R/W	
0047H	Rate no. of period 1 Start of period 1: minute	2	R/W	
0048H	Start of period 1: hour Rate no. of period 2	2	R/W	
0049H	Start of period 2: minute Start of period 2: hour	2	R/W	The first time list: Rate No.: 1: sharp 2: peak 3: flat 4: Valley

004AH	Rate no. of period 3 Start of period 3: minute	2	R/W	0: no rate	
004BH	Start of period 3: hour Rate no. of period 4	2	R/W		
004CH	Start of period 4: minute Start of period 4: hour	2	R/W		
004DH	Rate no. of period 5 Start of period 5: minute	2	R/W		
004EH	Start of period 5: hour Rate no. of period 6	2	R/W		
004FH	Start of period 6: minute Start of period 6: hour	2	R/W		
0050H	Rate no. of period 7 Start of period 7: minute	2	R/W		
0051H	Start of period 7: hour Rate no. of period 8	2	R/W		
0052H	Start of period 8: minute Start of period 8: hour	2	R/W		
0053H	Rate no. of period 1 Start of period 1: minute	2	R/W		The second time list Rate No.: 1: sharp 2: peak 3: flat 4: Valley 0: no rate
0054H	Start of period 1: hour Rate no. of period 2	2	R/W		
0055H	Start of period 2: minute Start of period 2: hour	2	R/W		
0056H	Rate no. of period 3 Start of period 3: minute	2	R/W		
0057H	Start of period 3: hour Rate no. of period 4	2	R/W		
0058H	Start of period 4: minute Start of period 4: hour	2	R/W		
0059H	Rate no. of period 5 Start of period 5: minute	2	R/W		
005AH	Start of period 5: hour Rate no. of period 6	2	R/W		
005BH	Start of period 6: minute Start of period 6: hour	2	R/W		
005CH	Rate no. of period 7 Start of period 7: minute	2	R/W		
005DH	Start of period 7: hour Rate no. of period 8	2	R/W		
005EH	Start of period 8: minute Start of period 8: hour	2	R/W		

005FH	Rate no. of period 9 Start of period 9: minute	2	R/W	
0060H	Start of period 9: hour	2	R/W	
0061H	Voltage of A phase	2	R	U=data*PT*0.1 Unit:V
0062H	Voltage of B phase	2	R	
0063H	Voltage of C phase	2	R	
0064H	Current of A phase	2	R	I=data*CT*0.01 Unit:A
0065H	Current of B phase	2	R	
0066H	Current of C phase	2	R	
0067H- 0076H	Reserve			
0077H	Frequency	2	R	F= data*0.01 Unit:Hz
0078H	Voltage between A-B	2	R	U=data*PT*0.1 Unit:V
0079H	Voltage between C-B	2	R	
007AH	Voltage between A-C	2	R	
007BH	Forward active maximum demand	2	R	Keep 3 decimal places for the maximum demand;
007CH	Time of occurrence :minute,hour	2	R	
007DH	Time of occurrence :day,month	2	R	
007EH	Reversing active maximum demand	2	R	
007FH	Time of occurrence :minute,hour	2	R	
0080H	Time of occurrence :day,month	2	R	
0081H	Maximum forward demand for reactive power	2	R	
0082H	Time of occurrence :minute,hour	2	R	

0083H	Time of occurrence :day,month	2	R	
0084H	Maximum reversing demand for reactive power	2	R	
0085H	Time of occurrence :minute,hour	2	R	
0086H	Time of occurrence :day,month	2	R	
0087H	Forward active energy of A phase	4	R	
0089H	Forward active energy of B phase	4	R	
008BH	Forward active energy of C phase	4	R	
008DH	Voltage transfer(PT)	2	R/W	
008EH	Current transfer(CT)	2	R/W	
008FH	State of DIDO, over-voltage, loss-voltage	2	R	
0090H	Reserve	2	R	
0091H high byte	Running state 1	1	R/W	
0091H low byte	Running state 2	1	R/W	
0092H	Zero sequence current	2	R	
0093H	Voltage imbalance	2	R	unit 0.1%
0094H	Current imbalance	2	R	
0095H	First communication path: Testing byte (High 8 bytes) Stop byte (Low 8 bytes)	2	R/W	testing byte: 0: none 2: even stop byte: 0: 1 stop byte 1: 2 stop bytes
0096H	Second communication path: Address (High 8 bytes) Baud rate (Low 8 bytes)	2	R/W	Same as the first communication path
0097H	Second communication path: Testing byte (High 8 bytes)	2	R/W	Same as the first communication

	Stop byte (Low 8 bytes)			path
0098H-00B1H	Reserved			
00B2H	Rate no. of period 9 Start of period 9: minute	2	R/W	The first time list: Rate No.: 1: sharp 2: peak 3: flat 4: Valley 0: no rate
00B3H	Start of period 9: hour Rate no. of period 10	2	R/W	
00B4H	Start of period 10: minute Start of period 10: hour	2	R/W	
00B5H	Rate no. of period 11 Start of period 11: minute	2	R/W	
00B6H	Start of period 11: hour Rate no. of period 12	2	R/W	
00B7H	Start of period 12: minute Start of period 12: hour	2	R/W	
00B8H	Rate no. of period 13 Start of period 13: minute	2	R/W	
00B9H	Start of period 13: hour Rate no. of period 14	2	R/W	
00BAH	Start of period 14: minute Start of period 14: hour	2	R/W	
00BBH	Rate no. of period 9 Start of period 9: minute	2	R/W	
00BCH	Start of period 9: hour Rate no. of period 10	2	R/W	
00BDH	Start of period 10: minute Start of period 10: hour	2	R/W	
00BEH	Rate no. of period 11 Start of period 11: minute	2	R/W	
00BFH	Start of period 11: hour Rate no. of period 12	2	R/W	
00C0H	Start of period 12: minute Start of period 12: hour	2	R/W	
00C1H	Rate no. of period 13 Start of period 13: minute	2	R/W	
00C2H	Start of period 13: hour Rate no. of period 14	2	R/W	
00C3H	Start of period 14: minute Start of period 14: hour	2	R/W	
00C4H ... 0163H	Reserved			

0164H	Active power of A phase	4	R	$PQS=data*PT*CT*0.001$ Unit:KW(active) kVar(reactive) kVA(apparent) Active power and reactive power are signed data, please set them as signed variables.
0166H	Active power of B phase	4	R	
0168H	Active power of C phase	4	R	
016AH	Total active power	4	R	
016CH	Reactive power of A phase	4	R	
016EH	Reactive power of B phase	4	R	
0170H	Reactive power of C phase	4	R	
0172H	Total reactive power	4	R	
0174H	Apparent power of A phase	4	R	
0176H	Apparent power of b phase	4	R	
0178H	Apparent power of c phase	4	R	
017AH	Total apparent power	4	R	
017CH	Power factor of A phase	2	R	$PF=data*0.001$ Data is signed data, please set them as signed variables.
017DH	Power factor of B phase	2	R	
017EH	Power factor of C phase	2	R	
017FH	Total power factor	2	R	
0180H	Maximum forward active demand a day	2	R	Keep three decimal places
0181H	Occur time:minute,hour	2	R	
0182H	Maximum reversing active demand a day	2	R	
0183H	Occur time:minute,hour	2	R	
0184H	Maximum forward reactive demand a day	2	R	

0185H	Occur time:minute,hour	2	R
0186H	Maximum reversing reactive demand a day	2	R
0187H	Occur time:minute,hour	2	R
0188H	Maximum forward active demand last day	2	R
0189H	Occur time:minute,hour	2	R
018AH	Maximum reversing active demand last day	2	R
018BH	Occur time:minute,hour	2	R
018CH	Maximum forward reactive demand last day	2	R
018DH	Occur time:minute,hour	2	R
018EH	Maximum reversing reactive demand last day	2	R
018FH	Occur time:minute,hour	2	R
0190H	Maximum forward active demand last 2 days	2	R
0191H	Occur time:minute,hour	2	R
0192H	Maximum reversing active demand last 2 days	2	R
0193H	Occur time:minute,hour	2	R
0194H	Maximum forward reactive demand last 2 days	2	R
0195H	Occur time:minute,hour	2	R
0196H	Maximum reversing reactive demand last 2 days	2	R
0197H	Occur time:minute,hour	2	R
0198H	Current forward active demand	2	R
0199H	Current reversing active demand	2	R

019AH	Current forward reactive demand	2	R	
019BH	Current reversing reactive demand	2	R	
019BH-01FFH	Reserved			
0200H	Maximum voltage on A phase	2	R	
0201H	Occur time:month,day	2	R	
0202H	Occur time:hour,minute	2	R	
0203H	Maximum voltage on B phase and occur time	6	R	
0206H	Maximum voltage on C phase and occur time	6	R	
0209H	Maximum current on A phase and occur time	6	R	
020CH	Maximum current on B phase and occur time	6	R	
020FH	Maximum current on C phase and occur time	6	R	
0212H	Maximum active power on A phase	4	R	
0214H	Occur time:month,day	2	R	
0215H	Occur time:hour,minute	2	R	
0216H	Maximum active power on B phase and occur time	8	R	
021AH	Maximum active power on C phase and occur time	8	R	
021EH	Maximum total active power and occur time	8	R	
0222H	Maximum reactive power on A phase and occur time	8	R	
0226H	Maximum reactive power on B phase and occur time	8	R	
022AH	Maximum reactive power on C phase and occur time	8	R	
022EH	Maximum total reactive power and occur time	8	R	
0232H	Maximum apparent power on A phase and occur time	8	R	
0236H	Maximum apparent power on B phase and occur time	8	R	
023AH	Maximum apparent power on C phase and occur time	8	R	
023EH	Maximum total apparent power and	8	R	

	occur time			
0242H	Minimum voltage on A phase and occur time	6	R	
0245H	Minimum voltage on B phase and occur time	6	R	
0248H	Minimum voltage on C phase and occur time	6	R	
024BH	Minimum current on A phase and occur time	6	R	
024EH	Minimum current on B phase and occur time	6	R	
0251H	Minimum current on C phase and occur time	6	R	
0254H	Minimum active power on A phase and occur time	8	R	
0258H	Minimum active power on B phase and occur time	8	R	
025CH	Minimum active power on C phase and occur time	8	R	
0260H	Minimum active power and occur time	8	R	
0264H	Minimum reactive power on A phase and occur time	8	R	
0268H	Minimum reactive power on B phase and occur time	8	R	
026CH	Minimum reactive power on C phase and occur time	8	R	
0270H	Minimum reactive power and occur time	8	R	
0274H	Minimum apparent power on A phase and occur time	8	R	
0278H	Minimum apparent power on B phase and occur time	8	R	
027EH	Minimum apparent power on C phase and occur time	8	R	
0280H	Minimum apparent power and occur time	8	R	
0285H-06FFH	Reserve			
0700H	Rate no. of period 1 Start of period 1: minute	2	R/W	The third time list Rate No.: 1: sharp
0701H	Start of period 1: hour	2	R/W	

	Rate no. of period 2			2: peak 3: flat 4: Valley 0: no ratet
0702H	Start of period 2: minute Start of period 2: hour	2	R/W	
0703H	Rate no. of period 3 Start of period 3: minute	2	R/W	
0704H	Start of period 3: hour Rate no. of period 4	2	R/W	
0705H	Start of period 4: minute Start of period 4: hour	2	R/W	
0706H	Rate no. of period 5 Start of period 5: minute	2	R/W	
0707H	Start of period 5: hour Rate no. of period 6	2	R/W	
0708H	Start of period 6: minute Start of period 6: hour	2	R/W	
0709H	Rate no. of period 7 Start of period 7: minute	2	R/W	
070AH	Start of period 7: hour Rate no. of period 8	2	R/W	
070BH	Start of period 8: minute Start of period 8: hour	2	R/W	
070CH	Rate no. of period 9 Start of period 9: minute	2	R/W	
070DH	Start of period 9: hour Rate no. of period 10	2	R/W	
070EH	Start of period 10: minute Start of period 10: hour	2	R/W	
070FH	Rate no. of period 11 Start of period 11: minute	2	R/W	
0710H	Start of period 11: hour Rate no. of period 12	2	R/W	
0711H	Start of period 12: minute Start of period 12: hour	2	R/W	
0712H	Rate no. of period 13 Start of period 13: minute	2	R/W	
0713H	Start of period 13: hour Rate no. of period 14	2	R/W	
0714H	Start of period 14: minute Start of period 14: hour	2	R/W	
0715H	Rate no. of period 1 Start of period 1: minute	2	R/W	The fourth time list Rate No.: 1: sharp 2: peak
0716H	Start of period 1: hour Rate no. of period 2	2	R/W	

0717H	Start of period 2: minute Start of period 2: hour	2	R/W	3: flat 4: Valley 0: no ratet
0718H	Rate no. of period 3 Start of period 3: minute	2	R/W	
0719H	Start of period 3: hour Rate no. of period 4	2	R/W	
071AH	Start of period 4: minute Start of period 4: hour	2	R/W	
071BH	Rate no. of period 5 Start of period 5: minute	2	R/W	
071CH	Start of period 5: hour Rate no. of period 6	2	R/W	
071DH	Start of period 6: minute Start of period 6: hour	2	R/W	
071EH	Rate no. of period 7 Start of period 7: minute	2	R/W	
071FH	Start of period 7: hour Rate no. of period 8	2	R/W	
0720H	Start of period 8: minute Start of period 8: hour	2	R/W	
0721H	Rate no. of period 9 Start of period 9: minute	2	R/W	
0722H	Start of period 9: hour Rate no. of period 10	2	R/W	
0723H	Start of period 10: minute Start of period 10: hour	2	R/W	
0724H	Rate no. of period 11 Start of period 11: minute	2	R/W	
0725H	Start of period 11: hour Rate no. of period 12	2	R/W	
0726H	Start of period 12: minute Start of period 12: hour	2	R/W	
0727H	Rate no. of period 13 Start of period 13: minute	2	R/W	
0728H	Start of period 13: hour Rate no. of period 14	2	R/W	
0729H	Start of period 14: minute Start of period 14: hour	2	R/W	
072AH- 1FFFH	Reserve			
2000H	T1 temperature	2	R	
2001H	T2 temperature	2	R	
2002H	T3 temperature	2	R	

9.2 History energy frozen time and history energy energy date

ADL3000-EF's registers on frozen by day and by month.

Address	Name	R/W	Note
0121H	Frozen time by day	R/W	Null (High byte) Hour(Low byte)
0122H	Frozen time by month	R/W	Day(High byte) Hour(Low byte)

ADL3000-EF can achieve the history energy statistic in last 48 months and last 90days. (Each tariff rate of energy can be recorded.)The history energy record can only be read by assemblage and the length of whole part is 120 byte (60 registers), and list below is the registers' name:

Address	Name	Data list	Name
1001H	Assemblage of last 1 month demand and energy	0000H	Frozen time: YY-MM
1002H	Assemblage of last 2 months demand and energy	0001H	Frozen time: DD-hh
...	...	0002H	Total forward active energy
1030H	Assemblage of last 48 months demand and energy	0004H	Spike forward active energy
1101H	Assemblage of last 1 day demand and energy	0006H	Peak forward active energy
1102H	Assemblage of last 2days demand and energy	0008H	Flat forward active energy
...	...	000AH	Valley forward active energy
115AH	Assemblage of last 90days demand and energy	000CH	Total reversing active energy
		000EH	Spike reversing active energy
		0010H	Peak reversing active energy
		0012H	Flat reversing active energy
		0014H	Valley reversing active energy
		0016H	Total forward reactive energy
		0018H	Spike forward reactive energy
		001AH	Peak forward reactive energy
		001CH	Flat forward reactive energy
		001EH	Valley forward reactive energy
		0020H	Total reversing reactive energy
		0022H	Spike reversing reactive energy
		0024H	Peak reversing reactive energy
		0026H	Flat reversing reactive energy

0028H	Valley reversing reactive energy
002AH	Active energy on A phase
002CH	Active energy on B phase
002EH	Active energy on C phase
0030H	Maximum forward active demand
0031H	Occur time: mm-hh
0032H	Occur time : DD-MM
0033H	Maximum reversing active demand
0034H	Occur time: mm-hh
0035H	Occur time : DD-MM
0036H	Maximum forward reactive demand
0037H	Occur time: mm-hh
0038H	Occur time : DD-MM
0039H	Maximum reversing reactive demand
003AH	Occur time: mm-hh
003BH	Occur time : DD-MM

9.3 Sub harmonic data

ADL3000-EH has function of harmonic. The function include 31st harmonic statistics of voltage and current, harmonic voltage and current of each phase apparently, harmonic active/reactive power of each phase apparently, fundamental voltage and current of each phase apparently and fundamental active/reactive power of each phase apparently.

Addr	Name	Length	R/W	Note
05DDH	THDUa	2	R	Total distortion rate of voltage and current on each phase Int Keep 3 decimal places
05DEH	THDUb	2	R	
05DFH	THDUc	2	R	
05E0H	THDIa	2	R	
05E1H	THDIb	2	R	
05E2H	THDIc	2	R	
05E3H	THUa	2×30		Harmonic voltage on 2 nd -31 st Int Keep 3 decimal places
0601H	THUb	2×30		
061FH	THUc	2×30		
063DH	THIa	2×30		Harmonic current on 2 nd -31 st Int Keep 2 decimal places
065BH	THIb	2×30		
0679H	THIc	2×30		

0697H	Fundamental voltage on A phase	2		Int Keep 1 decimal places
0698H	Fundamental voltage on B phase	2		
0699H	Fundamental voltage on C phase	2		
069AH	Harmonic voltage on A phase	2		
069BH	Harmonic voltage on B phase	2		
069CH	Harmonic voltage on C phase	2		
069DH	Fundamental current on A phase	2		Int Keep 2 decimal places
069EH	Fundamental current on B phase	2		
069FH	Fundamental current on C phase	2		
06A0H	Harmonic current on A phase	2		
06A1H	Harmonic current on B phase	2		
06A2H	Harmonic current on C phase	2		
06A3H	Fundamental active power on A phase	2		Int Keep 3 decimal places
06A4H	Fundamental active power on B phase	2		
06A5H	Fundamental active power on C phase	2		
06A6H	Total fundamental active power	2		
06A7H	Fundamental reactive power on A phase	2		
06A8H	Fundamental reactive power on B phase	2		
06A9H	Fundamental reactive power on C phase	2		
06AAH	Total fundamental reactive power	2		
06ABH	Harmonic active power on A phase	2		
06ACH	Harmonic active power on B phase	2		
06ADH	Harmonic active power on C phase	2		
06AEH	Total harmonic active power	2		
06AFH	Harmonic reactive power on A phase	2		
06B0H	Harmonic reactive power on B phase	2		
06B1H	Harmonic reactive power on C phase	2		
06B2H	Total harmonic reactive power	2		

9.4 SOE record

Address	Name	Data list	Name
3001H	Last event record	0000H	Occur date: YY-MM
3002H	Last 2 event record	0001H	Occur time: DD-hh
...	...	0002H	Occur time: mm-ss

3064H	Last 100 event record
-------	-----------------------

0004H	Event number
0005H	Event details
0006H	Reserve

Event num	Name	Details	Note
0100/0101	Power on/off		
0200	Clear	0001	Clear current energy
		0002	Clear history energy on Flash
		0003	Clear maximum demand
		0004	Clear history energy
		0005	Clear maximum value on a period
		0006	Clear out
0300	DO action	0000	DO off
		0001	DO on
0400	UI record	UI	Bit0: Over-voltage on A phase Bit1: Over-voltage on B phase Bit2; Over-voltage on C phase Bit3: Lose-voltage on A phase Bit4: Lose-voltage on B phase Bit5: Lose-voltage on C phase Bit6: Reversing on A phase Bit7: Reversing on B phase Bit8: Reversing on C phase Bit9: Over current on A phase Bit10: Over current on B phase Bit11: Over current on C phase Bit12: Low current on A phase Bit13:

			Low current on B phase Bit14: Low current on C phase
0700	Time calibration		

Example: The address is 001 at present, and we send the code: 01 03 30 01 00 06 9B 08 to get the last event record, and the slave station will give back: 01 03 0C 12 01 08 0A 01 01 (2018/1/8 10:1:1) 01 00(powered) 00 00(no details) 00 00(reserved) 80 23

Headquarters: Acrel Co., Ltd.

Trade Company: Acrel E-Business(Shanghai)Co., Ltd.

Address: No.253 Yulv Road, Jiading District, Shanghai, China

TEL.: 0086-21-69156352

Web-site: www.acrel-electric.com

E-mail: sales@acrel-electric.com

Postcode: 201801

Manufacturer: Jiangsu Acrel Electrical Manufacturing Co., Ltd.

Address: No.5 Dongmeng Road, Dongmeng industrial Park, Nanzha Street, Jiangyin City, Jiangsu
Province, China

TEL./Fax: 0086-510-86179970

Web-site: www.jsacrel.com

E-mail: sales@email.acrel.cn

Postcode: 214405

E-mail: sales@email.acrel.cn