

# ARTM-24 温度巡检仪

## ARTM-24 temperature measuring instrument

安装使用说明书 V1.2  
Installation & Operation Manual V1.2

# 申 明

## DECLARATION

版权所有，未经本公司之书面许可，此手册中任何段落，章节内容均不得被摘抄、拷贝或以任何形式复制、传播，否则一切后果由违者自负。

本公司保留一切法律权利。

All rights reserved. No part of this publication may be reproduced, stored in a retrieval system, or transmitted in any form by any means, electronic, mechanical photocopying, recording, or otherwise without prior permission of our company. The violator will bear the dependent legal responsibility.

We reserve all the rights.

本公司保留对本手册所描述之产品规格进行修改的权利，恕不另行通知。

订货前，请垂询当地代理商以获悉本产品的最新规格。

We reserve all the rights to revise product specification without notice. Please consult local agent to get the latest information of our products specification.

# 目 录

## Content

1. 安装使用指南 .....	1
1. Installation Guide .....	1
1.1 概述 .....	1
1.1 Overview .....	1
1.2 技术指标 .....	1
1.2 Technical Features .....	1
1.3 产品安装及尺寸 .....	3
1.3 Product Installation and size .....	3
1.4 接线方法 .....	4
1.4 Wiring method .....	4
1.5 传感器类型设置和通道投退说明 .....	6
1.5 Sensor type settings and channel switching instructions .....	6
1.5.1 调试软件传感器类型设置和通道投退设置 .....	6
1.5.1 Debug software sensor type settings and channel switching settings .....	6
1.6 告警说明 .....	8
1.6 Alarm description .....	8
1.6.1 调试软件告警设置 .....	8
1.6.1 Debug software alarm settings .....	8
1.7 传感器介绍 .....	11
1.7 Sensor introduction .....	11
1.7.1 PT100 参数 .....	11
1.7.1 PT100 parameter .....	11
1.7.1.1 PT100 规格 .....	11
1.7.1.1 PT100 Specifications .....	11
1.7.1.2 PT100 外形尺寸：（单位：mm） .....	11
1.7.1.2 PT100 dimensions: (unit: mm) .....	11
1.7.2 NTC 参数 .....	11
1.7.2 NTC parameters .....	11
1.7.2.1 NTC 规格 .....	11
1.7.2.1 NTC Specifications .....	11
1.7.2.2 NTC 外形尺寸：（单位：mm） .....	12
1.7.2.2 NTC dimensions: (unit: mm) .....	12
2. 通讯 .....	12
2.communication .....	12
2.1 通讯口通讯指南 .....	14
2.1 Communication port communication guide .....	14
2.2 通讯格式详解 .....	14
2.2Communication Examples .....	14

2.2.1 读取数据（功能码 03H/04H） .....	14
2.2.1 Read Data（Function code 03H/04H） .....	14
2.2.2 预置单个寄存器（功能码 06H） .....	15
2.2.2 Preset Single Register（Function code 06H） .....	15
2.2.3 预置多个寄存器（功能码 10H） .....	15
2.2.3 Preset Multi Registers（Function code 10H） .....	15
2.3 通讯地址表 .....	16
2.3 Parameter Address Table .....	16

## 1. 安装使用指南

### 1. Installation Guide

#### 1.1 概述

##### 1.1 Overview

ARTM-24 温度巡检仪可接入 NTC、PT100/PT1000、热电偶传感器，主要应用于低压电气节点、变压器绕组、电机绕组等场所测温。

ARTM-24 temperature measuring instrument can be connected to NTC, PT100/PT1000, thermocouple sensors, mainly used in low-voltage electrical nodes, transformer windings, motor windings and other places to measure temperature.



图 1.1 ARTM-24  
Figure1.1 ARTM-24

#### 1.2 技术指标

##### 1.2 Technical Features

技术指标 Technical Features	指标 Features
功能 Function	ARTM-24
测量通道数 Number of measurement channels	24

输入信号 Input signal		<p>NTC: R25=10.00k<math>\Omega</math>; B25/50=3380K;          NTC: R25=50.00k<math>\Omega</math>; B25/50=4150K;          NTC: R25=100.00k<math>\Omega</math>; B25/50=3950K;          PT100/PT1000: 三线制;          PT100/PT1000: Three-wire system;          热电偶支持 K、T、J、E、N 型。          Thermocouple supports K, T, J, E, N types.</p>
测温范围 Measurement Range		<p>NTC: -40<math>^{\circ}</math>C~140<math>^{\circ}</math>C;          PT100: 最大支持-200<math>^{\circ}</math>C~850<math>^{\circ}</math>C, 实际范围视 PT100 定;          PT100: Maximum support -200<math>^{\circ}</math>C~850<math>^{\circ}</math>C, the actual range depends on PT100;          PT1000: 最大支持-200<math>^{\circ}</math>C~850<math>^{\circ}</math>C, 实际范围视 PT1000 定;          PT1000: Maximum support -200<math>^{\circ}</math>C~850<math>^{\circ}</math>C, the actual range depends on PT1000;          热电偶: 最大支持-200<math>^{\circ}</math>C~1372<math>^{\circ}</math>C, 实际范围视热电偶型号定。          Thermocouple: maximum support -200<math>^{\circ}</math>C~1372<math>^{\circ}</math>C, the actual range depends on the thermocouple model.</p>
精度等级 (标准信号) Accuracy class (standard signal)		<p>NTC: <math>\pm 1^{\circ}</math>C;          PT100/PT1000: -200<math>^{\circ}</math>C~200<math>^{\circ}</math>C, <math>\pm 1^{\circ}</math>C; +200<math>^{\circ}</math>C~850<math>^{\circ}</math>C, <math>\pm 1\%</math>;          热电偶: 1%。          Thermocouple: 1%.</p>
辅助电源 Auxiliary power	电压范围 voltage range	AC85~265V/DC100-350V,DC12~30V
	功耗 Power	$\leq 2$ W
报警输出 Alarm Output	路数 Channel	2 组常开 2 groups of normally open
	容量 Capacity	AC250V/5A,DC30V/5A
温湿度输入 Temperature and humidity input	路数 Channel	1 (选配) 1 (optional)
	环境温度 Temp	$\pm 1^{\circ}$ C
	环境湿度	$\pm 3\%$

	HUM	
通讯 Communication	协议 Protocol	MODBUS-RTU
	接口 Interface	RS485
	波特率 Baud rate	2400,4800,9600,19200
环境要求 Environment	工作温度 TEMP	-20°C~55°C
	工作湿度 HUM	<=95%

### 1.3 产品安装及尺寸

#### 1.3 Product Installation and size

ARTM-24 温度巡检仪，采用导轨（DIN35mm）安装方式。

ARTM-24 temperature measuring instrument, using guide rail (DIN35mm) installation method.



图 1.2 ARTM-24 尺寸图

Figure1.2 ARTM-24 Dimensions

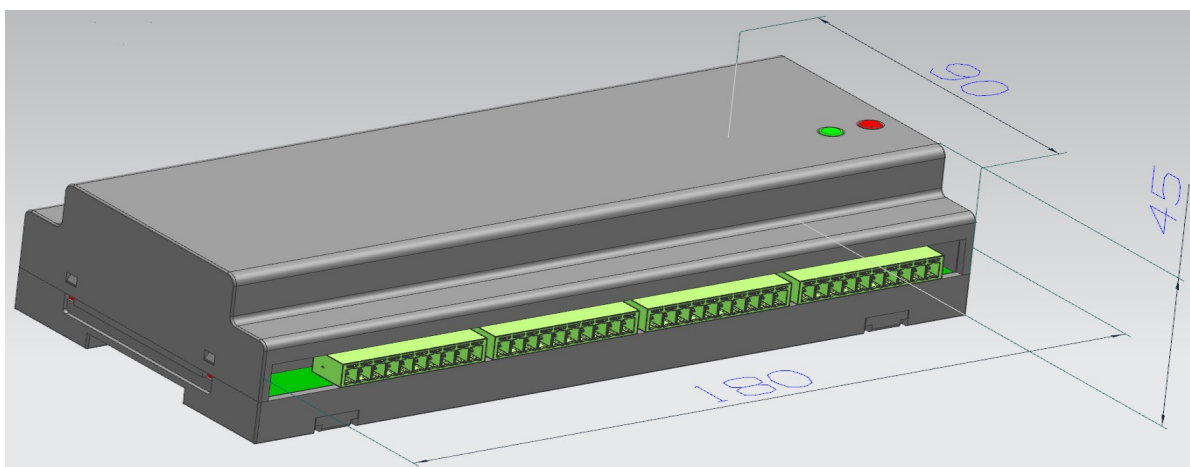

图 1.3 ARTM-24 安装图  
Figure 1.3 ARTM-24 installation diagram

## 1.4 接线方法

### 1.4 Wiring method

1、2 号为辅助电源端子，3、4 号为 DO1 输出，5、6 号为 DO2 输出，7、8 号为 RS485 接口的 B、A 端子，71、72、73、74 号为为温湿度的 V+、CLK、DATA、V- 端子。

No. 1 and 2 are auxiliary power terminals, No. 3 and 4 are DO1 output, No. 5 and 6 are DO2 output, No. 7 and 8 are terminals B and A of RS485 interface, No. 71~74 are V+, CLK, DATA, V- terminals for temperature and humidity.

PT100/PT1000 接线参考图 1.4。11~13 号为 PT100/PT1000 的第 1 路接线端子，13~15 号为 PT100/PT1000 的第 2 路接线端子，以此类推。PT100/PT1000 为一根 A 线，两根 B 线，将 PT100/PT1000 的 A 线接入端子标号为 A 的端子号，两根 B 线接入标号为 B 和 C 标号的端子号。

Refer to Figure 1.4 for wiring of PT100/PT1000. No. 11~13 are the first terminal of PT100/PT1000, No. 13~15 are the second terminal of PT100/PT1000, and so on. PT100/PT1000 has one A line and two B lines. Connect the A line of the PT100/PT1000 to the terminal number labeled A, and connect the two B lines to the terminal numbers labeled B and C.

NTC 接线参考图 1.5。12~13 号为 NTC 的第 1 路接线端子，13~14 号为 NTC 的第 2 路接线端子，以此类推。

Refer to Figure 1.5 for NTC wiring. No. 12~13 are the terminals of the NTC's channel 1, No. 13~14 are the terminals of the NTC's channel 2, and so on.

热电偶接线参考图 1.6。11~12 号为热电偶的第 1 路接线端子，11 号接 TC-，12 接 TC+，14~15 号为热电偶的第 2 路接线端子，14 号接 TC+，15 号接 TC-，以此类推。

Refer to Figure 1.6 for thermocouple wiring. No. 11~12 are the first terminal of thermocouple, No. 11 is connected to TC-, No. 12 is connected to TC+, No. 14~15 is the second terminal of thermocouple, No. 14 is connected to TC+, The 15th is connected to TC-, and so on.





图 1.4 ARTM-24 PT100 接线图

Figure 1.4 ARTM-24 PT100 wiring diagram

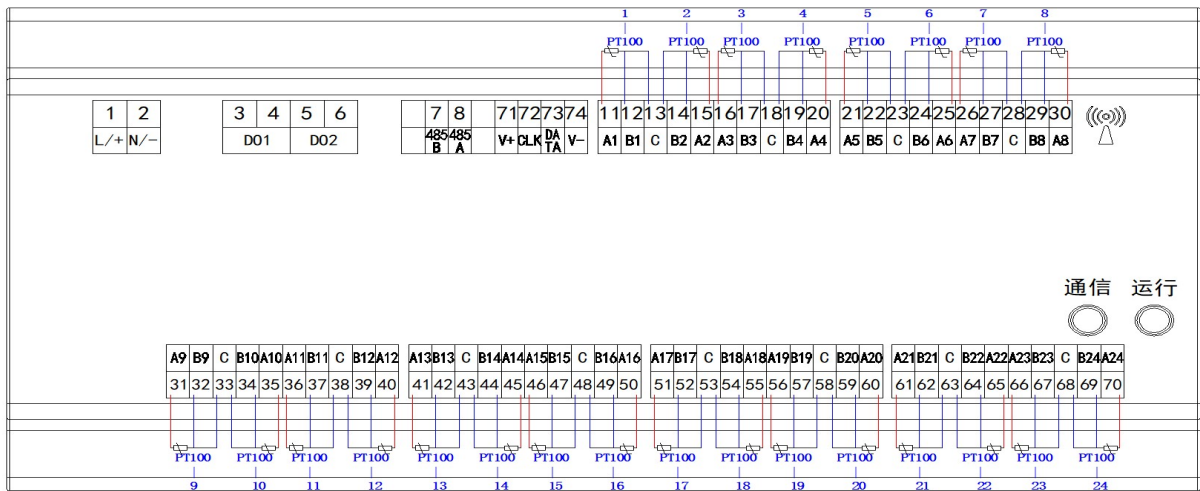

图 1.5 ARTM-24 NTC 接线图 Figure

Figure 1.5 ARTM-24 NTC wiring diagram

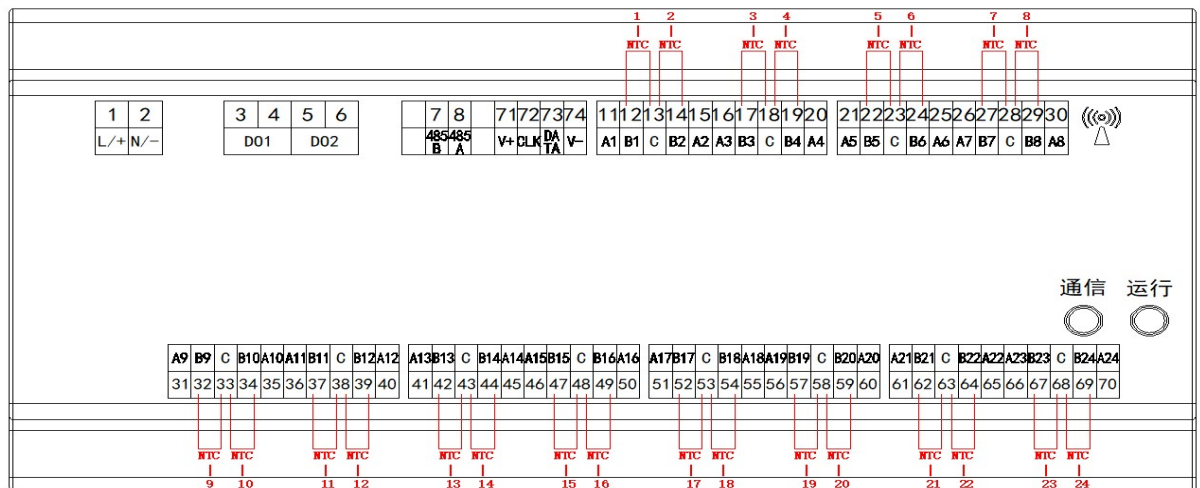

图 1.6 ARTM-24 热电偶接线图

Figure 1.6 ARTM-24 Thermocouple Wiring Diagram

## 1.5 传感器类型设置和通道投退说明

### 1.5 Sensor type settings and channel switching instructions

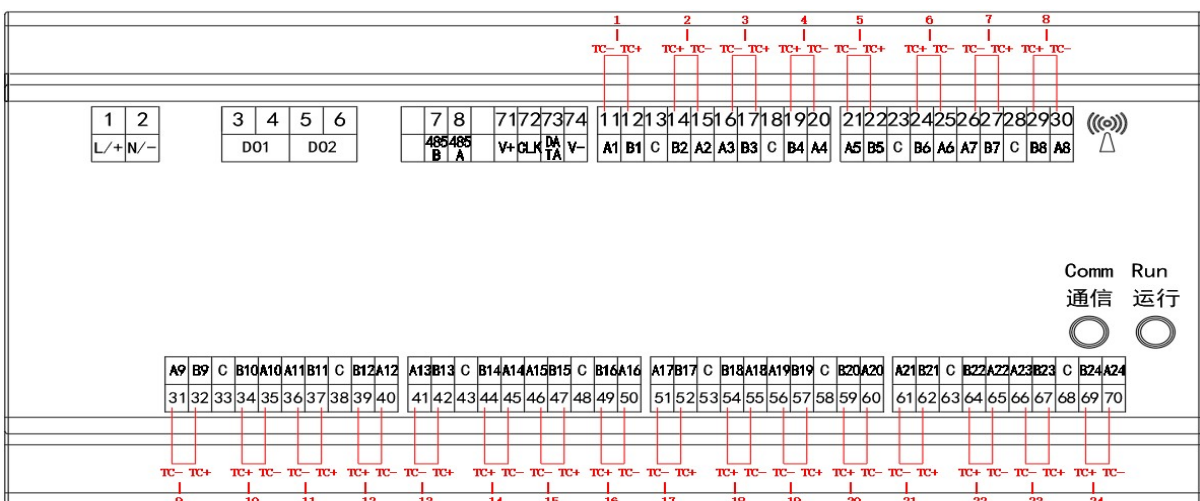
#### 1.5.1 调试软件传感器类型设置和通道投退设置

#### 1.5.1 Debug software sensor type settings and channel switching settings

打开“ARTM-24 调试软件”，点击“通讯”按钮，端口选择电脑中对应设备端口（可通过右击我的电脑-属性-设备管理器-端口，查看对应的端口）。如图 1.7 所示。

Open "ARTM-24 debugging software", click "Communication" button, and select the corresponding device port in your computer (you can check the corresponding port by right-clicking My Computer - Properties - Device Manager - Port). As shown in Figure 1.7.



图 1.7 设备端口

Figure 1.7 Device Ports

选择波特率，默认 9600，点击“连接”，设备类型一栏显示型号和版本，表示装置已经连接成功，可以通讯。如图 1.8 所示。

Select the baud rate, the default is 9600, click "Connect", the model and version will be displayed in the device type column, indicating that the device has been successfully connected and can communicate. As shown in Figure 1.8.

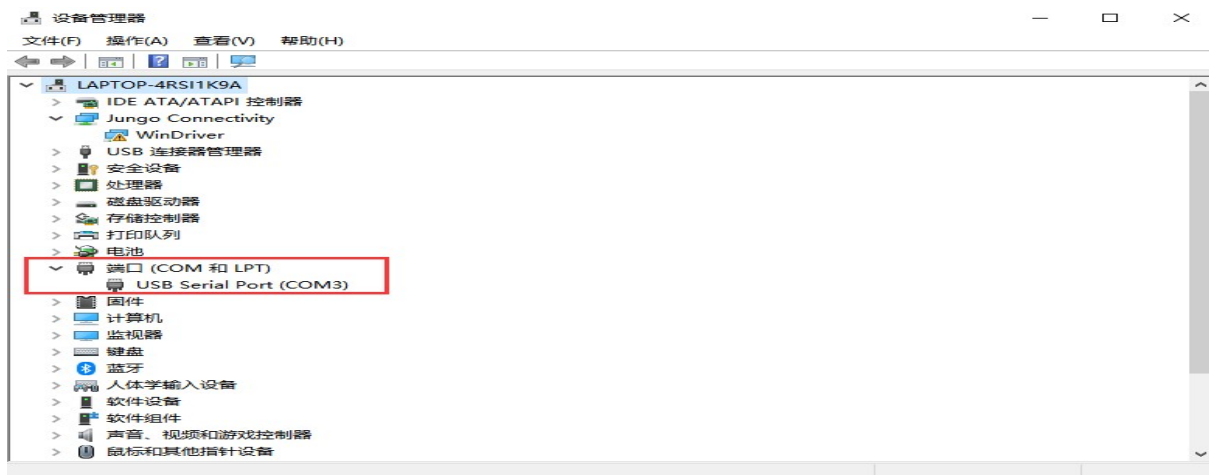
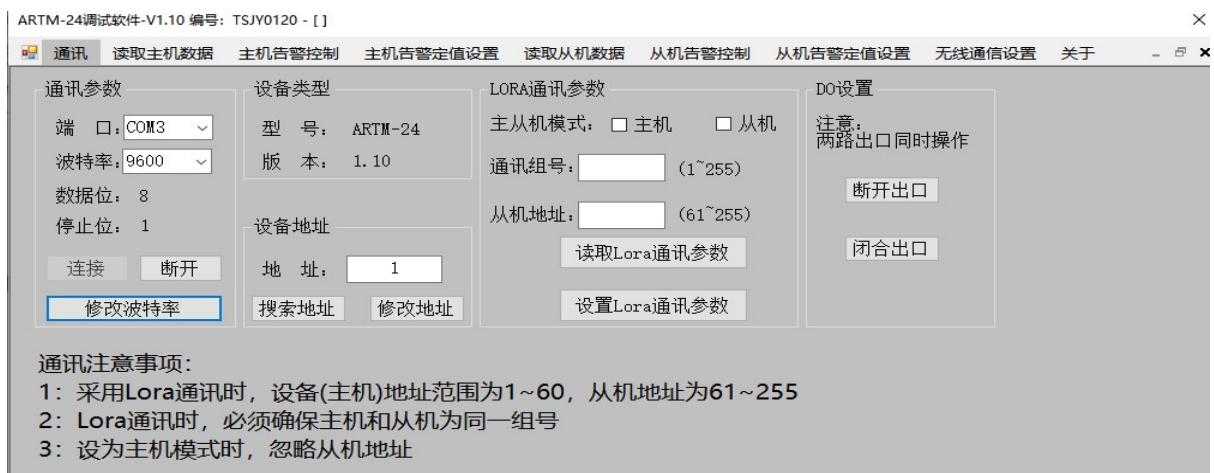



图 1.8 ARTM-24 调试软件通讯界面

Figure 1.8 ARTM-24 debugging software communication interface

在“主机参数设置”界面，按照装置所接的传感器类型进行选择，点击“配置传感器”按钮，根据装置接入的传感器路数勾选接线通道，并点击“写入通道控制字”按钮即可完成设置。如图 1.9 所示。

In the "Host Set" interface, select according to the type of sensor connected to the device, click the "Configure the sensor" button, Check the wiring channel according to the number of sensors connected to the device, and click the "Write Channel Control Word" button to complete the setting. As shown in Figure 1.9.

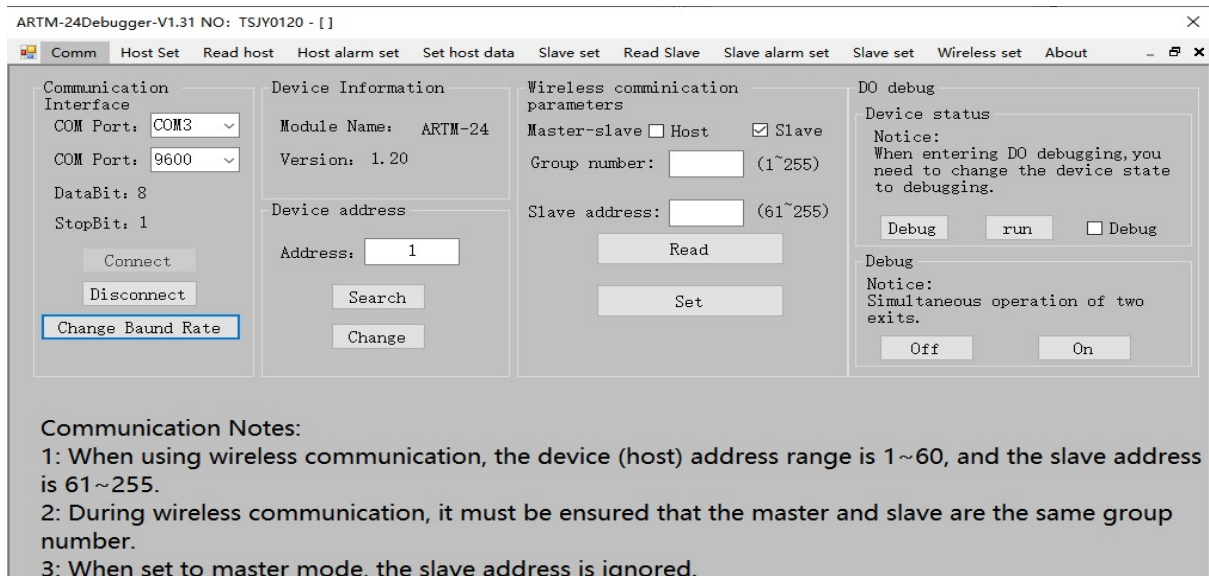
**注：**如果将传感器类型设置为热电偶类型，设置完成后，请将装置重新上电。

**NOTE:** If the sensor type is set to thermocouple type, power cycle the unit after the setting is complete.





图 1.9 ARTM-24 调试软件主机参数设置界面

Figure 1.9 ARTM-24 debugging software host parameter setting interface

## 1.6 告警说明

### 1.6 Alarm description

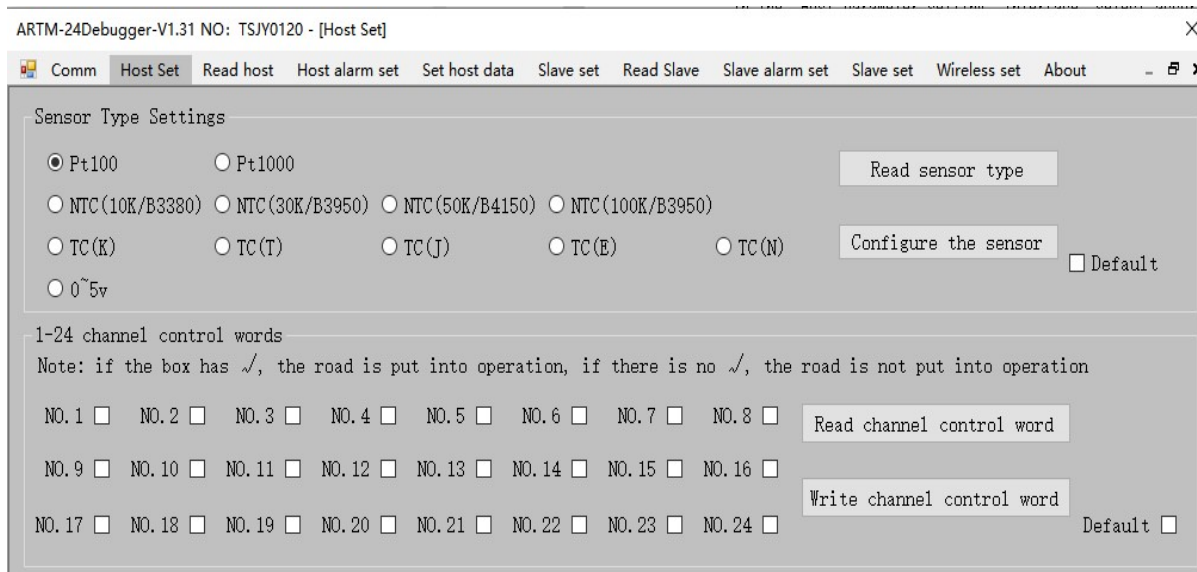
ARTM-24 温度巡检仪每一路可分别投入或退出告警功能，默认为 24 路全部投入。

Each channel of the ARTM-24 temperature measuring instrument can be turned on or off the alarm function separately, and all 24 channels are turned on by default.

装置告警功能有两种越限告警机制，分别为 AL1 越限告警和 AL2 越限告警，且告警方向均可设为高温或低温告警。AL1 默认告警方向为高温告警，告警值为 60°C，回滞量默认为 0；AL2 默认告警方向为高温告警，告警值为 80°C，回滞量默认为 0。

The device alarm function has two alarm mechanisms for exceeding the limit, namely AL1 exceeding the limit alarm and AL2 exceeding the limit alarm, and the alarm direction can be set to high temperature or low temperature alarm. The default alarm direction of AL1 is high temperature alarm, the alarm value is 60°C, and the default hysteresis value is 0; the default alarm direction of AL2 is high temperature alarm, the alarm value is 80°C, and the default hysteresis value is 0.

DO1 出口对应 24 路的 AL1 告警功能，当 AL1 设为高温告警，测量值>告警值，DO1 闭合；测量值<告警值-回滞量，DO1 断开；AL1 告警设为低温告警，测量值<告警值，DO1 闭合；测量值>告警值+回滞量，DO1 断开；DO2 出口对应 24 路的 AL2 告警功能，告警逻辑同 DO1 出口。

The DO1 outlet corresponds to the AL1 alarm function of 24 channels. When AL1 is set to high temperature alarm, the measured value > alarm value, DO1 is closed; the measured value < alarm value - hysteresis, DO1 is disconnected; AL1 alarm is set to low temperature alarm, and the measured value < Alarm value, DO1 is closed; measured value > alarm value + hysteresis, DO1 is open; DO2 outlet corresponds to the 24-channel AL2 alarm function, and the alarm logic is the same as DO1 outlet.

#### 1.6.1 调试软件告警设置

##### 1.6.1 Debug software alarm settings

在“主机告警控制”界面，点击“读取告警控制字”按钮，可查看 24 路告警控制字投退状态；只需对 24 路选择为投入或不投入后点击“写入告警控制字”按钮，即可更改告警投退。如图 1.10 所示。

In the "Host Alarm Control" interface, click the "Read Alarm Control Word" button to view the

24-way alarm control word throwback status; just select "Put in" or "No Put in" for the 24-way and then click the "Write Alarm Control Word" button. "button, you can change the alarm throwback. As shown in Figure 1.10.

点击“读取 AL1 告警设置”按钮，可查看 24 路 AL1 告警方向；对 24 路的 AL1 告警设置选择为高温或低温告警后点击“写入 AL1 告警设置”按钮即可完成设置；AL2 告警设置同 AL1 告警设置。如图 1.10 所示。

Click the "Host alarm set" button to view the direction of the 24-channel AL1 alarms; select the high temperature or low temperature alarm for the 24-channel AL1 alarm settings, and click the "Write AL1" button to complete the settings; AL2 alarm settings are the same as AL1 alarm settings. As shown in Figure 1.10.



图 1.10 ARTM-24 调试软件主机告警设置界面

Figure 1.10 ARTM-24 debugging software host alarm setting interface

在“主机告警定值控制”界面，点击“刷新 1-24 路告警定值”按钮，可查看 24 路 AL1 和 AL2 告警温度定值；如需更改 1-8 路 AL1 和 AL2 告警温度定值，只需输入所需 1-8 路 AL1 和 AL2 温度告警定值后点击“写入 1-8 路告警定值”即可完成设置；9-16 路、17-24 路告警定值设置同 1-8 路告警定值设置。如图 1.11 所示。

In the interface of "Set host data", click the "Refresh 1-24" button to view the 24-way AL1 and AL2 alarm temperature setting; if you need to change the 1-8 AL1 and AL2 alarm temperature setting, Just enter the required AL1 and AL2 temperature alarm settings for 1-8 channels and click "Write 1-8" to complete the setting; 9-16 channels, 17-24 channels alarm settings are the same as 1- 8-way alarm setting. As shown in Figure 1.11.

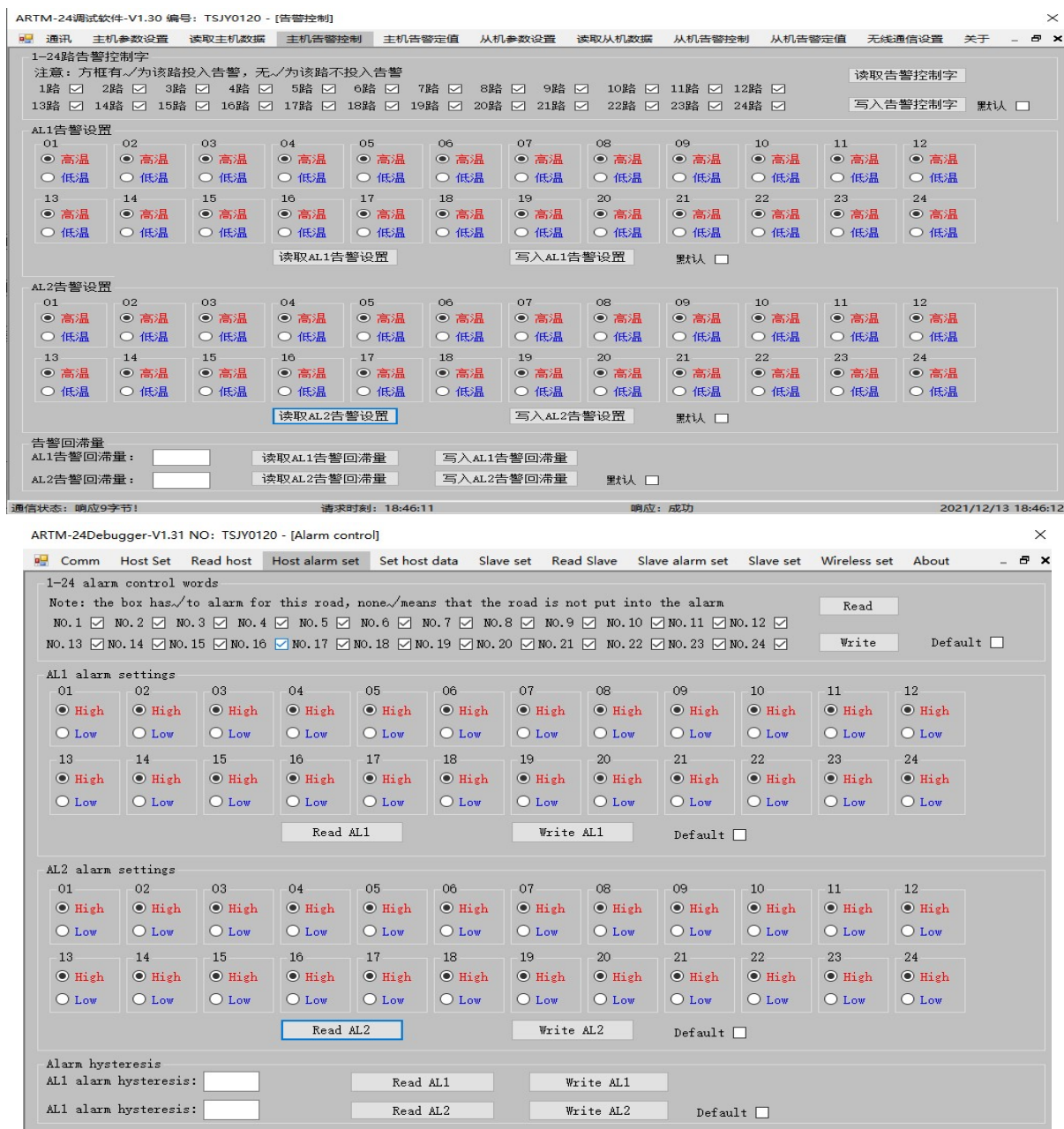

图 1.11 ARTM-24 调试软件主机告警定值设置

Figure 1.11 ARTM-24 debugging software host alarm settings

## 1.7 传感器介绍

### 1.7 Sensor introduction

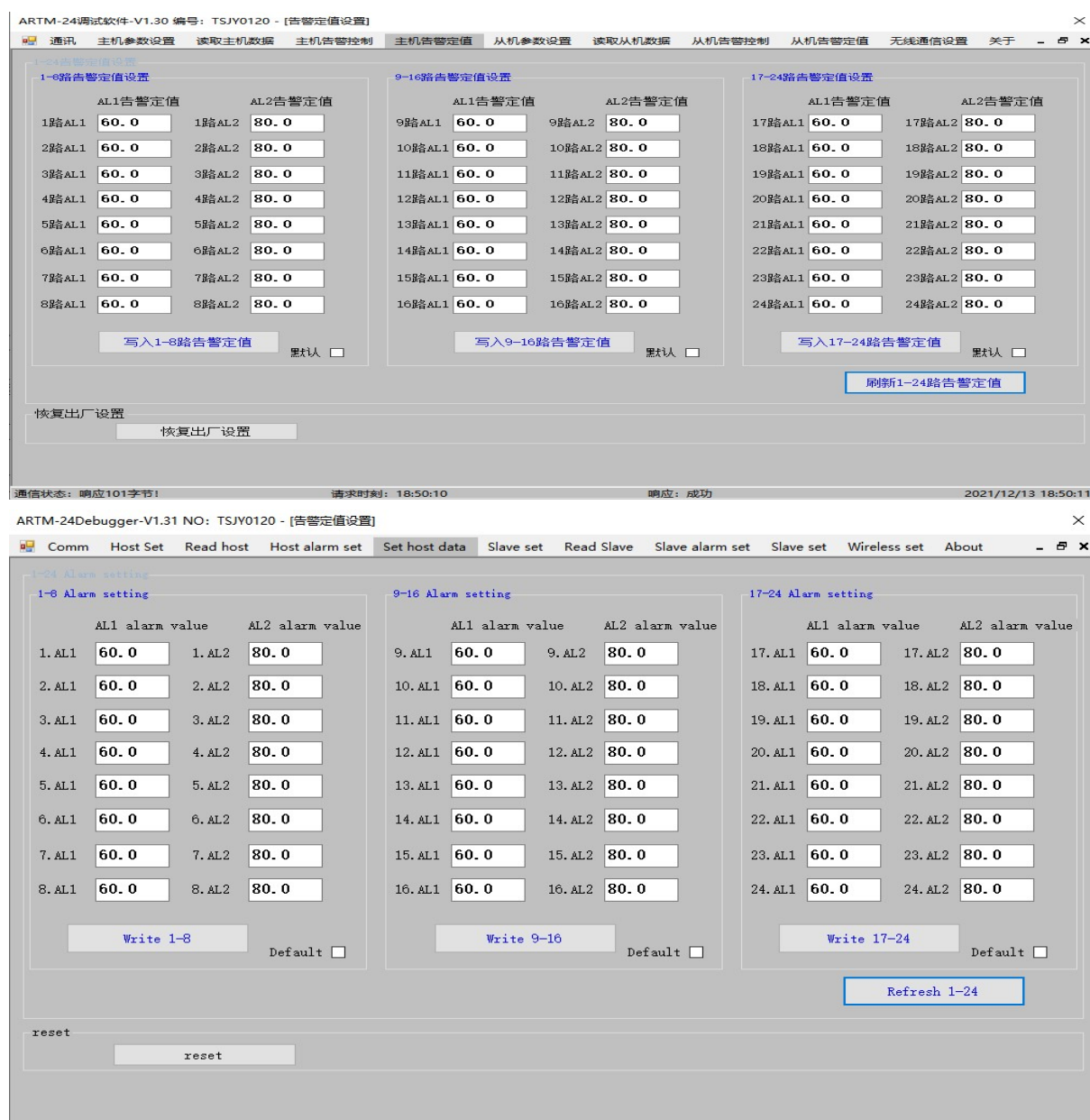
#### 1.7.1 PT100 参数

#### 1.7.1 PT100 parameter

##### 1.7.1.1 PT100 规格

##### 1.7.1.1 PT100 Specifications

名称/型号 name/model	TPS01TP100-2000
测温范围 Measurement Range	-50~200°C
接线方式 Wiring	三线制 three-wire system
长度 length	2 米 2 meters

##### 1.7.1.2 PT100 外形尺寸：（单位：mm）

##### 1.7.1.2 PT100 dimensions: (unit: mm)



图 1.12 ARTM-24 PT100 尺寸图

Figure 1.12 ARTM-24 PT100 dimension drawing

#### 1.7.2 NTC 参数

#### 1.7.2 NTC parameters

##### 1.7.2.1 NTC 规格

##### 1.7.2.1 NTC Specifications

名称/型号 name/model	NTC-B150B/YT $\varnothing$ 12-V01-2M NTC-B150B/YT $\varnothing$ 12-V01-4M NTC-B150B/YT $\varnothing$ 8-V01-2M NTC-B150B/YT $\varnothing$ 8-V01-4M
测温范围 Measurement Range	-40~140°C

阻值 Resistance	R25=50.00k $\Omega$ $\pm$ 1%; B25/50=4150K $\pm$ 1%
长度 length	2 米或 4 米 2 meters or 4 meters

1.7.2.2 NTC 外形尺寸：（单位：mm）

1.7.2.2 NTC dimensions: (unit: mm)



图 1.13 ARTM-24 NTC(φ8)尺寸图

Figure 1.13 ARTM-24 NTC (φ8) dimension drawing

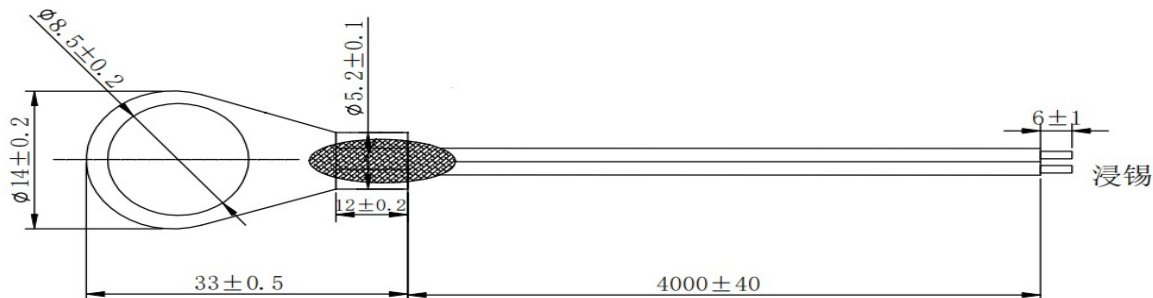

图 1.14 ARTM-24 NTC(φ12)尺寸图

Figure 1.14 ARTM-24 NTC (φ12) dimension drawing

## 2. 通讯

### 2.communication

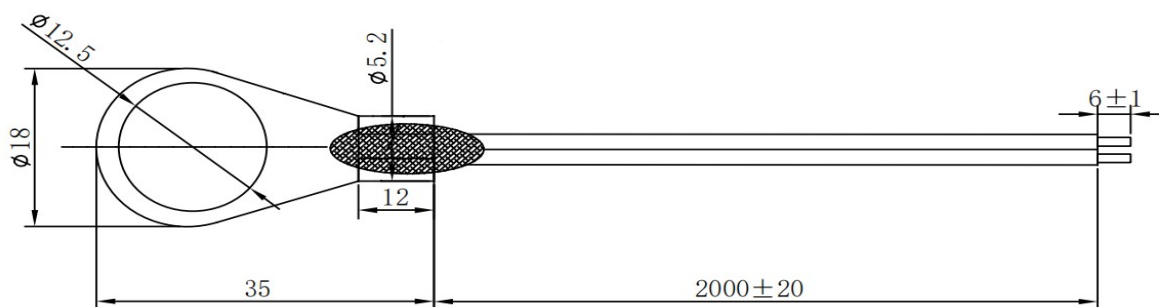
ARTM-24 通讯共有两种方式，分别为 485 通讯口通讯和无线通讯。

无线通讯时需设置三个无线通讯参数。

- 1: 无线通讯主从机模式
- 2: 无线通讯通讯组号
- 3: 无线通讯从机地址

无线通讯分为主从机模式，主从机需设置为相同的组号，组号范围为 1~255；无线通信主机，需根据实际使用需求设置 485 通讯地址，范围为 1-60。无线通信从机只需设置从机无线通信地址，范围 61~255。上位机通过 485 与主机相连，即可通过无线的方式对从机的数据进行查询与更改。

ARTM-24 communication has two ways, namely 485 communication port communication and wireless communication.

Three wireless communication parameters need to be set during wireless communication.



1: wireless communication master-slave mode

2: Wireless communication group number

3: Wireless communication slave address

The wireless communication is divided into master-slave mode, the master-slave should be set to the same group number, the group number range is 1~255; the wireless communication host needs to set the 485 communication address according to the actual use requirements, the range is 1-60. The wireless communication slave only needs to set the wireless communication address of the slave, ranging from 61 to 255. The host computer is connected to the host computer through 485, and the data of the slave computer can be inquired and changed wirelessly.

例：主机 485 通讯口通讯地址为 1，主机无线通讯组号为 1；从机无线通讯组号为 1，从机无线通讯地址为 61(0x3D)。如图 2.1 所示。

For example: the communication address of the host's 485 communication port is 1, the host's wireless communication group number is 1; the slave's wireless communication group number is 1, and the slave's wireless communication address is 61 (0x3D). As shown in Figure 2.1.

1.查询主机数据

上位机发：01 03 00 00 00 03 05 CB

主机回：01 03 06 00 01 25 80 00 00 16 51

2.查询从机数据

上位机发：3D 03 00 00 00 03 00 F7

从机回：3D 03 06 00 01 25 80 00 00 17 50

两种通讯方式的通讯地址均参考 2.3 通讯地址表。

1. Host query local data

The upper computer sends: 01 03 00 00 00 03 05 CB

Master back: 01 03 06 00 01 25 80 00 00 16 51

2. The host queries the slave data

The upper computer sends: 3D 03 00 00 00 03 00 F7

Slave back: 3D 03 06 00 01 25 80 00 00 17 50

Refer to 2.3 Communication Address Table for the communication addresses of the two communication methods.



图 2.1 通信拓扑图  
Figure 2.1 Communication topology diagram

## 2.1 通讯口通讯指南

### 2.1 Communication port communication guide

在本章主要讲述如何利用软件通过通讯口来操控 24 路温度巡检仪。本章内容的掌握需要您具有 MODBUS 协议的知识储备并且通读了本册其他章节所有内容，对本产品功能和应用概念有较全面的了解。本章内容包括：通讯应用格式详解，本机的参量地址表。

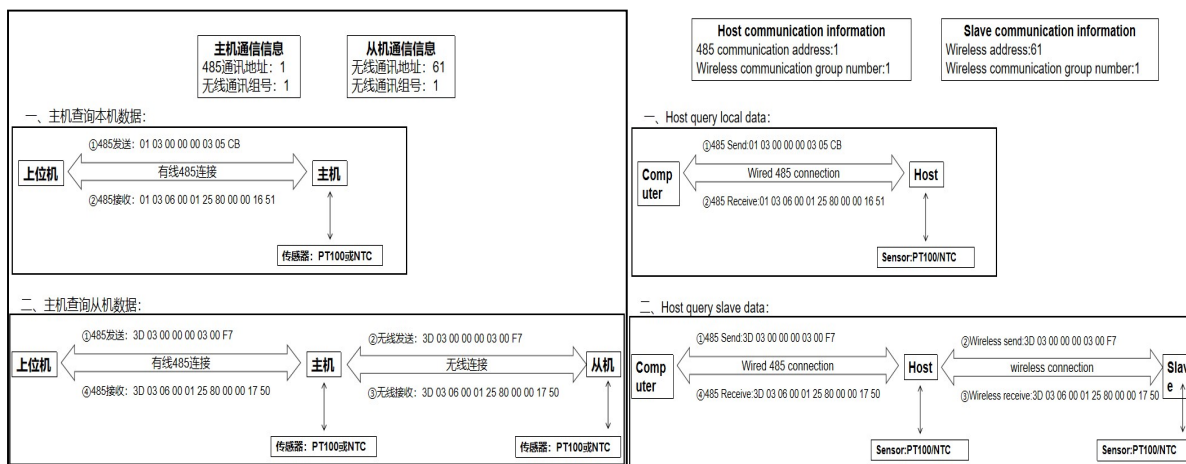
This chapter mainly describes how to use the software to control the 24-channel temperature inspection instrument through the communication port. To master the contents of this chapter, you need to have the knowledge reserve of MODBUS protocol and read all the contents of other chapters in this book thoroughly, and have a more comprehensive understanding of the functions and application concepts of this product. This chapter includes: detailed explanation of communication application format, parameter address table of this machine.

## 2.2 通讯格式详解

### 2.2 Communication Examples

本节所举实例将尽可能的使用如下表所示的格式，数据为十六进制。

The examples in this section will use the format shown in the following table as much as possible, and the data is in hexadecimal.

#### 2.2.1 读取数据（功能码 03H/04H）

#### 2.2.1 Read Data (Function code 03H/04H)

此功能允许用户获得设备采集与记录的数据及系统参数。主机一次请求的数据个数没有限制，但不能超出定义的地址范围。

This function allows the user to get the data measured and system parameters recorded by slave. There is no limit of data length for asking data, but it cannot exceed the range of defined address.

例如，主机发送查询数据帧：

For example, master send data frame:

地址 Addr	功能码 Fun	起始地址		寄存器数量		CRC16 校验码	
		Register Addr		Register Count		CRC16	
		高 Hi	低 Lo	高 Hi	低 Lo	低 Lo	高 Hi
01H	03H	00H	00H	00H	03H	05H	CBH

装置返回响应数据帧：

Slave answer data frame:

地址 Addr	功能码 Fun	字节数 Byte count	数据 1		数据 2		数据 3		CRC16 校验码	
			Data 1		Data 2		Data 3		CRC16	
			高 Hi	低 Lo	高 Hi	低 Lo	高 Hi	低 Lo	低 Lo	高 Hi
01H	03H	06H	00H	01H	25H	80H	00H	00H	16H	51H

### 2.2.2 预置单个寄存器（功能码 06H）

#### 2.2.2 Preset Single Register（Function code 06H）

此功能码允许用户改变单个寄存器的内容，可通过此功能码将工作参数写入装置。

User can write active parameter into the single register with this function code.

例如，主机发送：

For example, master send data frame:

地址	功能码	寄存器地址		预置值		CRC16 校验码	
		高	低	高	低	高	低
01H	06H	00H	00H	00H	02H	08H	0BH

装置返回响应数据帧：

Slave answer data frame:

地址 Addr	功能码 Fun	寄存器地址		预置值		CRC16 校验码	
		Register Addr		Value		CRC16	
		高 Hi	低 Lo	高 Hi	低 Lo	低 Lo	高 Hi
01H	06H	00H	00H	00H	02H	08H	0BH

### 2.2.3 预置多个寄存器（功能码 10H）

#### 2.2.3 Preset Multi Registers（Function code 10H）

此功能码允许用户改变多个寄存器的内容，可通过此功能码将工作参数写入装置。

User can write active parameter into the multi registers with this function code.

例如，主机发送：

For example, master send data frame:

地址 Addr	功能 码 Fun	起始地址 Register Addr		寄存器数 Register Count		字节 数 Byte Coun t	预置值 1 Value 1		预置值 2 Value 2		CRC16 校验码 CRC16	
		高 Hi	低 Lo	高 Hi	低 Lo		高 Hi	低 Lo	高 Hi	低 Lo		
01H	10H	00H	00H	00H	02H	04H	00H	02H	25H	80H	49H	5FH

装置返回响应数据帧:

Slave answer data frame:

地址 Addr	功能码 Fun	起始地址 Register Addr		寄存器数量 Register Count		CRC16 校验码 CRC16	
		高字节 Hi	低字节 Lo	高字节 Hi	低字节 Lo	低字节 Hi	高字节 Lo
01H	10H	00H	00H	00H	02H	41H	C8H

## 2.3 通讯地址表

### 2.3 Parameter Address Table

地址 Address	参数 Address	属性 <sup>1)</sup> Attribute	数值范围 Range	数据类型 Data type
0000H	通讯地址 Address	R/W	无线模式为主机模式，地址范围：1-60，默认为 1；无线模式为从机模式，地址范围：1-247，默认为 1 Wireless mode is master mode, address range: 1-60, the default is 1; wireless mode is slave mode, address range: 1-247, default is 1	UWord
0001H	通讯波特率 Baud rate	R/W	2400, 4800, 9600, 19200; 默认为 9600	UWord
0002H	继电器输出状态 Relay Output	R/W	bit0~bit1: AL1 告警, AL2 告警 bit0~bit1: high temperature alarm, over temperature alarm	UWord
0003H	1-16 路 AL1 告警 设置 1-16 AL1 alarm settings	R/W	bit0~bit15: 每一位对应一个路 AL1 的告警设置, 0-低告警, 1-高告警 Bit0~bit15: Each bit corresponds to the alarm setting of one channel AL1, 0-low alarm, 1-high alarm	UWord
0004H	17-24 路 AL1 告警 设置 17-24 AL1 alarm settings	R/W	bit0~bit7: 每一位对应一个路 AL1 的告警设置, 0-低告警, 1-高告警 Bit0~bit7: Each bit corresponds to the alarm setting of one channel AL1, 0-low alarm, 1-high alarm	UWord

0005H	1-16 路 AL2 告警设置 1-16 AL2 alarm settings	R/W	bit0~bit15: 每一位对应一个路 AL2 的告警设置, 0-低告警, 1-高告警 Bit0~bit15: Each bit corresponds to the alarm setting of one channel of AL2, 0-low alarm, 1-high alarm	UWord
0006H	17-24 路 AL2 告警设置 17-24 AL2 alarm settings	R/W	bit0~bit7: 每一位对应一个路 AL2 的告警设置, 0-低告警, 1-高告警 Bit0~bit7: Each bit corresponds to the alarm setting of AL2, 0-low alarm, 1-high alarm	UWord
0007H	环境温度 Ambient temperature	R	环境温度范围: $-50\sim 85.0 (\times 10)^{[2]}$ Ambient temperature range: $-50\sim 85.0 (\times 10)^{[2]}$	Word
0008H	环境湿度 Environment humidity	R	环境湿度范围: $0\sim 100.0 (\times 10)^{[2]}$ Environmental humidity range: $0\sim 100.0 (\times 10)^{[2]}$	Word
0009H	1-16 路 AL1 告警状态 1-16 AL1 alarm status	R	0-正常, 1-告警。bit0~bit15: 1 路~16 路 AL1 告警状态 1-0-normal, 1-alarm. bit0~bit15: 1 to 16 AL1 alarm status	UWord
000AH	17-24 路 AL1 告警状态 17-24 AL1 alarm status	R	0-正常, 1-告警。bit0~bit7: 17 路~24 路 AL1 告警状态 0-normal, 1-alarm. bit0~bit7: 17 to 24 AL1 alarm status	UWord
000BH	1-16 路 AL2 告警状态 1-16 AL2 alarm status	R	0-正常, 1-告警。bit0~bit15: 1 路~16 路 AL2 告警状态 0-normal, 1-alarm. bit0~bit15: 1 to 16 AL2 alarm status	UWord
000CH	17-24 路 AL2 告警状态 17-24 AL2 alarm status	R	0-正常, 1-告警。bit0~bit7: 17 路~24 路 AL2 告警状态 0-normal, 1-alarm. bit0~bit7: 17 to 24 AL2 alarm status	UWord
000DH	1~16 路告警控制字 1~16 Alarm control words	R/W	0-退出, 1-投入; bit0~bit15: 1~16 路 0-exit, 1-input; bit0~bit15: 1~16 channels	UWord
000EH	17~24 路告警控制字 17~24 Alarm control words	R/W	0-退出, 1-投入; bit0~bit7: 17~24 路 0-exit, 1-input; bit0~bit7: 17~24 channels	UWord
000FH-03EH	传感器温度告警定值 Sensor temperature alarm setting	R/W	告警温度定值: 第 1 路 AL1 告警设定值, 第 1 路 AL2 告警设定值~第 24 路 AL1 告警设定值, 第 24 路 AL2 告警设定值; 范围: $-200^{\circ}\text{C}\sim 1372^{\circ}\text{C} (\times 10)^{[2]}$ Alarm temperature setting value: 1st channel	Word * 48

			AL1 alarm setting value, 1st channel AL2 alarm setting value ~ 24th channel AL1 alarm setting value, 24th channel AL2 alarm setting value; range: -200°C~1372°C (x10) <sup>[2]</sup>	
003FH-0056H	温度传感器温度值 Temperature sensor temperature value	R	1~24 路温度值; NTC 范围: -40°C~140°C (X10) <sup>[2]</sup> ; PT100/PT1000 范围: -200°C~850°C (X10) <sup>[2]</sup> ; 热电偶范围: -200°C~1372°C(X10) <sup>[2]</sup> 1~24 temperature values; NTC range: -40°C~140°C(X10) <sup>[2]</sup> ; PT100/PT1000 range: -200°C~850°C(X10) <sup>[2]</sup> ; Thermocouple range: -200°C~1372 °C (X10) <sup>[2]</sup>	Word * 24
0057H	AL1 告警回滞量 AL1 alarm hysteresis	R/W	告警回滞量范围: 0~100 Alarm hysteresis range: 0~100	UWord
0058H	AL2 告警回滞量 AL2 alarm hysteresis	R/W	告警回滞量范围: 0~100 Alarm hysteresis range: 0~100	UWord
0059H	预留 Reserved	R/W		UWord
005AH	预留 Reserved	R/W		UWord
005BH	无线通信运行模式 Wireless communication operating mode	R/W	0-主机模式, 1-从机模式, 默认为 1 0-Master mode, 1-Slave mode, the default is 1	UWord
005CH	无线通信通讯组号 Wireless communication group number	R/W	1-255, 默认为 1 1-255, the default is 1	UWord
005DH	无线通信从机地址 Wireless communication slave address	R/W	61-255, 默认为 61, 主机模式时忽略从机地址 61-255, the default is 61, the slave address is ignored in the master mode	UWord
005EH-0075H	传感器温升值 Sensor temperature rise	R	1~24 路温升值,范围-200°C~1372°C (X10) <sup>[2]</sup> 1~24 way temperature rise, range -200°C~1372°C (X10) <sup>[2]</sup>	Word*24
0076H-008DH	温度校准 Temperature calibration	W	1-24 路温度校准, 范围: -200°C~1372°C(X10) <sup>[2]</sup> 1-24 channels temperature calibration, range: -200°C~1372°C (X10) <sup>[2]</sup>	Word*24

008EH-00A5H	温度极值 Temperature extremes	R	1-24 路温度极值,范围:-200°C~1372°C(X10) <sup>[2]</sup> 1-24 way temperature extreme value, range: -200°C~1372°C (X10) <sup>[2]</sup>	Word*24
00A6H	传感器类型 Sensor type	R/W	0-PT100, 1-PT1000, 2-K 型热电偶, 3-T 型热电偶, 4-J 型热电偶, 5-E 型热电偶, 6-N 型热电偶, 7-预留, 8-NTC(10K_B3380), 9-NTC(50K_B4150), 10-NTC(100K_B3950) 0-PT100, 1-PT1000, 2-K type thermocouple, 3-T type thermocouple, 4-J type thermocouple, 5-E type thermocouple, 6-N type thermocouple, 7-reserved,8-NTC(10K_B3380),9-NTC(50K_B 4150), 10-NTC(100K_B3950)	UWord
00A7H	1~16 路通道控制 字 1~16 Channel control words	R/W	bit0~bit15: 每一位对应一个通道投退, 0-关闭, 1-开启 bit0~bit15: Each bit corresponds to a channel switching, 0-off, 1-on	UWord
00A8H	17-24 路通道控制 字 17-24 Channel control words	R/W	bit0~bit7: 每一位对应一个通道投退, 0-关闭, 1-开启 bit0~bit7: Each bit corresponds to a channel switching, 0-off, 1-on	UWord

注: [1] R—只读; W—只写; R/W—读/写。[2] ×10—读取时实际值乘以相应的倍数上传, 写入时应乘以相应的倍数写入。

Note: [1] R—read only; W—write only; R/W—read/write. [2] ×10—The communication value is 10 times the actual value.

总部：安科瑞电气股份有限公司

地址：上海市嘉定区育绿路 253 号

电话：0086-021-69158161

网址：www.acrel.cn

邮箱：acrelsh@email.acrel.cn

邮编：201801

生产基地：江苏安科瑞电器制造有限公司

地址：江苏省江阴市南闸街道东盟工业园区东盟路 5 号

电话：0086-510-86179966

网址：www.jsacrel.cn

邮箱：jyacrel001@email.acrel.cn

邮编：214405

Headquarters: Acrel Co., Ltd.

Trade Company: Acrel E-Business(Shanghai)Co., Ltd.

Address: No.253 Yulv Road, Jiading District, Shanghai, China

TEL.: 0086-21-69156352

Web-site: www.acrel-electric.com

E-mail: sales@acrel-electric.com

Postcode: 201801

Manufacturer: Jiangsu Acrel Electrical Manufacturing Co., Ltd.

Address: No.5 Dongmeng Road, Dongmeng industrial Park, Nanzha Street, Jiangyin City,

Jiangsu Province, China

TEL./Fax: 0086-510-86179970

Web-site: www.jsacrel.com

E-mail: sales@email.acrel.cn

Postcode: 214405