

472



ARD2M

电动机保护器使用说明书
Motor Protector Operating Manual

V1.7

安科瑞电气股份有限公司

ACREL Co., Ltd

申 明

Declaration

版权所有，未经本公司之书面许可，此手册中任何段落，章节内容均不得被摘抄、拷贝或以任何形式复制、传播，否则一切后果由违者自负。

All rights reserved. Without the written permission of the Company, the contents of any paragraph or section in this manual shall not be copied, copied or disseminated in any form. Otherwise, all consequences shall be borne by the violator.

本公司保留一切法律权利

Our company reserves all legal rights.

本公司保留对本手册所描述之产品规格进行修改的权利，恕不另行通知。订货前，请垂询当地代理商以获悉本产品的最新规格。

Our company reserves the right to modify the product specifications described in this manual without prior notice. Before placing an order, please consult your local agent for new specifications of this product.

目录

Catalog

1、概述 Overview.....	- 1 -
2、产品特点 Product Features.....	- 1 -
3、型号说明 Model Description.....	- 2 -
4、主要参数 Main parameters.....	- 4 -
5、外形尺寸及安装 Overall dimensions and installation.....	- 6 -
6、保护功能说明 Protection function description.....	- 11 -
7、功能设置与说明 Display module introduction.....	- 28 -
8、通讯设置与说明 Communication Settings and instructions.....	- 43 -
9、特色功能简介 Features and Functions.....	- 76 -
10、订货范例 Examples of ordering.....	- 78 -

1、概述 Overview

ARD2M 电动机保护器（以下简称保护器）适用于额定电压至 380V 的低压电动机回路，集保护、测量、控制、通讯、运维于一体。其完善的保护功能确保电动机安全运行，带有逻辑可编程功能，可以满足多种控制方式。The ARD2M motor protector (hereinafter referred to as the protector) is suitable for low-voltage motor circuits with rated voltage up to 380V and integrates protection, measurement, control, communication, operation and maintenance. Its perfect protection function ensures the safe operation of the motor, with logic programmable function, can meet a variety of control methods.

该产品有一体式和分体式两种结构选择，由主体、互感器组成，可适应各种柜体的安装。

The product adopts split structure, which is composed of main body, panel, mutual inductor and optional communication module, and can adapt to the installation of various cabinets.

产品执行标准 Product Implementation standards:

——**GB/T14048.4-2020** 低压开关设备和控制设备第 4-1 部分：接触器和电动机起动器机电式接触器和电动机起动器(含电动机保护器)；

——**GB/T14048.4-2020** Low-voltage switchgear and control gear -- Part 4-1: Contactors and motor starters -- Electromechanical contactors and motor starters (including motor protectors);

——JBT 10736-2007 低压电动机保护器。

——JB/T 10736-2007 Low voltage motor protector.

2、产品特点 Product Features

- 支持电力参数测量 (U、I、P、Q、S、PF、F、EP、EQ) ， 电流及电流不平衡度、电流正序、负序、零序分量、电压、三相电压相角、剩余电流。
- Support power parameter measurement (U, I, P, Q, S, PF, F, EP, EQ), voltage and current imbalance degree, voltage and current positive sequence, negative sequence, zero sequence component, three-phase voltage phase Angle, residual current.
- 保护功能包括过载反时限、过载定时限、接地、起动超时、漏电、欠载、断相、堵转、阻塞、短路、溢出、不平衡(电流、电压)、过功率、欠功率、过压、欠压、相序、温度、tE 时间、外部故障、起动次数限制、运行时间报警、故障次数报警。
- Protection functions include overload inverse time, overload definite time, grounding, starting timeout, leakage, underload, locked-rotor, obstruction, short circuit, phase, overflow, imbalance (current, voltage, power, less power, over voltage, under voltage, phase sequence, temperature, external fault, tE time, running time alarm, fault alarm.
- 8 路可编程 DI 输入，默认采用内置 DC24V 电源，也可选择外部有源湿接点。
- 8 channels programmable DI input, the default use of DC24V power supply, or external active wet contact can be selected (see the selection table).
- 5 路可编程 DO 输出，满足直接起动，星—三角起动，自耦变压器起动，等多种起动方式，可通过通讯总线实现主站对电动机的遥控“起/停”。
- 5 programmable DO output, to meet the direct starting, star - triangle starting, auto-transformer starting, and other starting modes, can be through the communication bus to achieve the master station to the motor remote control "start/stop".
- 可选抗晃电功能：支持晃电立即再启动、失压重起动。
- Optional anti-shaking function: support immediate restart of shaking power and restart of voltage loss.
- 标配 MODBUS_RTU 通讯，可选配 PROFIBUS DP 通讯，支持最多 2 路通讯接口。
- MODBUS_RTU and PROFIBUS DPV1 communication modules are available for selection. 2 MODBUS_RTU communication channels or MODBUS_RTU+PROFIBUS DPV1 communication modules can be chosen.

- 可选配 1 路 4-20mA 模拟量输出接口，与 DCS 系统相接，可实现对现场设备的监控。
- Optional 1 channels DC4-20MA analog output interface, connected with DCS system, can realize the monitoring of field equipment.
- 具有故障记录、起动记录、停车记录、DI 变位记录和再起动力记录等各类事件记录。
- With fault record, start record, stop record, DI displacement record, restart record and other records of various events, you can view a number of motor operation and maintenance information.
- 显示界面液晶显示，支持中/英文切换。
- The display interface supports Chinese/English LIQUID crystal display

3、型号说明 Model Description

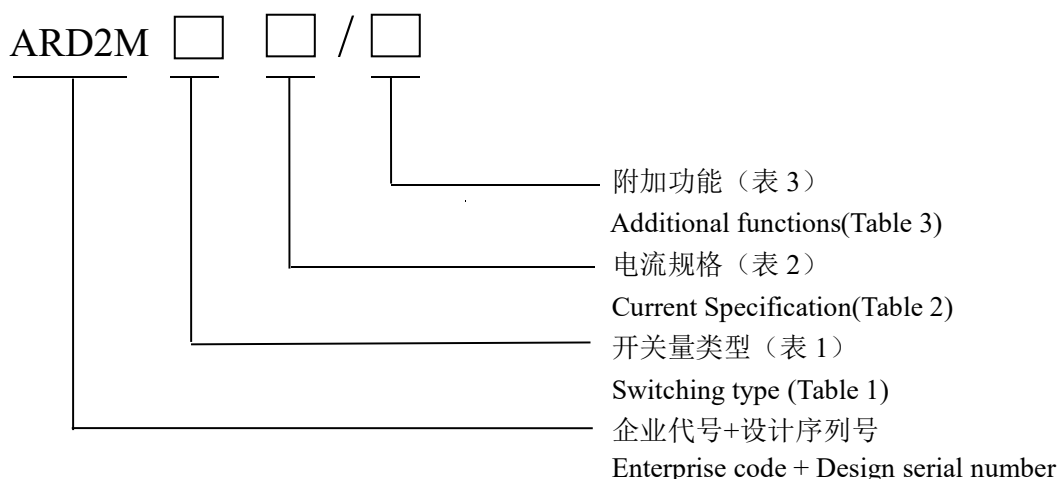

ARD2M 标配开关量数量为 8DI、5DO，开关量类型见表 1：

The standard switch quantity of ARD2M is 8DI and 5DO, and the switch quantity type is shown in Table 1:

表 1 Table 1

主体开关量分类 Main switch classification	代号 Code
DI 为干结点，DO 外部电源为 AC220V DI is the dry contact, and the external power supply of DO is AC220V	K1
DI 为湿结点，DC110V 输入，DO 外部电源为 AC220V DI is the wet contact, the input is DC110V, and the external power supply of DO is AC220V	K2
DI 为湿结点，DC220V 输入，DO 外部电源为 AC220V DI is the wet contact, the input is DC220V, and the external power supply of DO is AC220V	K3
DI 为湿结点，AC220V 输入，DO 外部电源为 AC220V DI is the wet contact, AC220V input, and DO external power supply is AC220V	K4

ARD2M 电流规格与适用电机额定电流、功率对应关系见表 2:

The corresponding relation between ARD2M current specification and the rated current and power of the applicable motor is shown in Table 2:

表 2 Table 2

保护器电流规格 Protector current specification (A)	变比设置 Ratio setting	互感器一次侧圈数 Primary side coil number of transformer	适用电机范围 Applicable scope of motor(kW)	适用电机额定电流范围 Suitable for motor Rated current range(A)
1	支持	1 圈 1circle	0.12-999	0.1-5000
5	Support	1 圈 1circle	0.12-999	0.5-5000
25	不支持 Does not support	1 圈 1circle	3-11	6.3-25
100		1 圈 1circle	15-45	25-100
250		1 圈 1circle	55-132	63-250
800		1 圈 1circle	160-250	250-800

ARD2M 附加功能见表 3:

Additional function of ARD2M are shown in Table 3:

表 3 Table 3

附加功能 Additional function		代号 code	附加功能 Additional function		代号 code
电能 Energy metering		Ep	事件记录 SOE Event record		SR
4-20mA 变送输出 4-20mA analog output		M	温度保护 Temperature protection		T
单通讯 1channel communication	1 路 Modbus_RTU 通讯 Modbus-RTU	C	双通讯 2channel communication	2 路 Modbus_RTU 通讯 Modbus-RTU	2C
	1 路 PROFIBUS_DP V0 通讯 Profibus-DP	CP		1 路 Modbus_RTU+1 路 PROFIBUS_DP V0 通讯 Modbus-RTU+ Profibus-DP	CCP
抗晃电功能 Anti - electric shock function		SU	漏电保护 Leakage protection		L

备注 Remarks:

(1)额定电流在 0.4A-1.6A 范围的电动机可选择 1A 规格的电动机保护器，互感器穿芯 1 匝使用；电流范围在 1.6-6.3A 的电动机选择 5A 规格的保护器，穿芯 1 匝使用。

(1)The motor with rated current of 0.4-1.6A can choose the 1A specification motor protector,and the transformer is wound 1 times.The motor with rated current of 1.6-6.3A can choose the 5A specification motor protector,and the transformer is wound 1 time.

(2)100A 及以下电流规格的一体式保护器使用一体式电流互感器；

100A 及以下电流规格的分体式保护器使用分体式电流互感器；

250A、800A 电流规格使用另外一种分体式电流互感器。互感器外观尺寸详见“外形尺寸及安装”部分。

(2) Integrated current transformer is used for integrated protector with current specification of 100A and below;

The split current transformer is used for the current specification of 100A and below;

250A and 800A current specifications use another type of split current transformer. For the external dimensions of the

transformer, please refer to the "external dimensions and installation".

(3)温度测量支持传感器类型为 PTC 或者 NTC 或者 PT100。

(3)The temperature measurement support sensor type is PTC or NTC or PT100.

(4)选配漏电功能 (L) 后, 每台保护器自配一只漏电互感器, 漏电互感器尺寸详见“外形尺寸及安装”部分。漏电互感器标配 2m±10cm 二次线, 如需其它长度可同厂家联系。

(4)After the leakage function (L) is selected, each protector is equipped with a leakage transformer. The dimensions of the leakage transformer are shown in the section "overall dimensions and installation". Leakage transformer is equipped with 2m ± 10cm secondary line as standard. If you need other length, please contact the manufacturer.

4、主要参数 Main parameters

4.1 技术指标 Technical indicators

ARD2M 技术指标见表 4:

ARD2M technical indicators are shown in Table 4:

表 4 Table 4

技术参数 Technical parameters	技术指标 Technical indicators	
保护器辅助电源 Protector auxiliary power supply	AC85-265V/DC100-350V	
电机额定工作电压 Rated working voltage of the motor	AC220V / 380V, 50Hz / 60Hz	
电动机额定工作电流 Rated operation current of the motor	1 (0.1A-1.6A)	一体式/分体式互感器 Integrated/Split current transformer
	5 (1.6A-6.3A)	
	25(6.3A-25A)	
	100(25A-100A)	
	250(63A-250A)	分体式互感器 Split current transformer
800(250A-800A)		
继电器输出触点容量 Relay output contact capacity	阻性负载 Impedance load	AC250V、10A
开关量输入 Switching input	8 路无源干结点 (可选配有源 DC110V、DC220V、AC220V 输入) 8 channels of passive dry contact (active DC110V, DC220V, AC220V input can be optional)	
通讯 Communication	RS485 Modbus_RTU, Profibus_DP 协议 RS485 Modbus_RTU, Profibus_DP Protocol	
环境 Environment	工作温度 Working temperature	-10°C~55°C
	贮存温度 Storage temperature	-25°C~70°C
	相对湿度 Relative temperature	≤95% 不结露, 无腐蚀性气体 ≤95% No condensation, no corrosive gas
	海拔	≤2000m

	Altitude	
污染等级 Pollution levels	3 级 3 level	
防护等级 Protection grade	IP65（安装在柜体面板时） IP65(installed on the cabinet panel)	
安装类别 Installation category	III 级 III level	

4.2 功能配置 Functional configuration

ARD2M 功能配置见表 5:

ARD2M Functional configuration shown in Table 5:

表 5 Table 5

功能 Function		型式 Type	功能配置 Functional configuration	
			标配功能 Standard function	选配功能 Optional function
保护功能 Protection function	定时限过载 Fixed time overload		√	
	反时限过载 Inverse time overload		√	
	起动超时 Starting timeout		√	
	断相 Phase loss		√	
	电压不平衡 Voltage unbalance		√	
	电流不平衡 Current unbalance		√	
	堵转 Locked-Rotor		√	
	欠载 underload		√	
	外部故障 External fault		√	
	阻塞 Block		√	
	温度保护（PTC/NTC） Temperature protection(PTC/NTC)			√
	剩余电流(二选一)		√	√（漏电）(leakage)
	Residual current(One only)			
	接地 grounding			
	漏电 leakage			
	相序 Phase sequence		√	
	欠压 Under voltage		√	
	过压 Over voltage		√	
	欠功率 Under power		√	
	过功率 Over power		√	
tE 时间保护 Te time protection		√		
溢出保护 Overflow protection		√		
起动次数报警 Alarm of starting times		√		
运行时间报警 Running time alarm		√		
故障次数报警 Fault frequency alarm		√		
控制方式 Control mode	保护模式 Protection mode		√	
	手动模式 Direct start mode		√	
	两步模式 Two-step mode			
	双速模式 Two-speed mode			

	晃电再启动 Voltage loss restart	√	
通讯功能 Communication function	1 路 Modbus-RTU 通讯 1 channel Modbus-RTU communication	√	
	2 路 Modbus-RTU 通讯 2 channels Modbus-RTU communication		√
	1 路 Profibus-DP 通讯 1 channel Profibus-DP communication		√
开关量输入 Switching input	8 路 DI 8 channel DI	√	
继电器输出 Relay output	5 路 DO 5 channel DO	√	
模拟量输出 Analog output	1 路 4-20mA 1 channel 4-20mA		√
事件记录 Event record	起动记录、停车记录、DI 变位记录、再起动记录、运行记录（支持通讯传输） Start record, stop record, DI displacement record, restart record, (support communication transmission)	√	

5、外形尺寸及安装 Overall dimensions and installation

5.1 产品组成 Composition

ARD2M 产品组成如图 1、图 2 所示：

The product composition of ARD2M is shown in Figure 1, Figure 2:



图 1 一体式保护器产品组成

Figure1 The composition of integrated protector

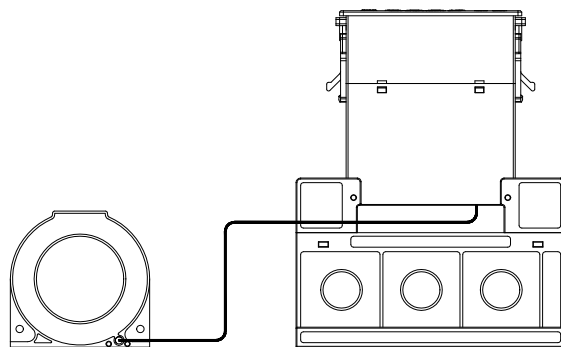
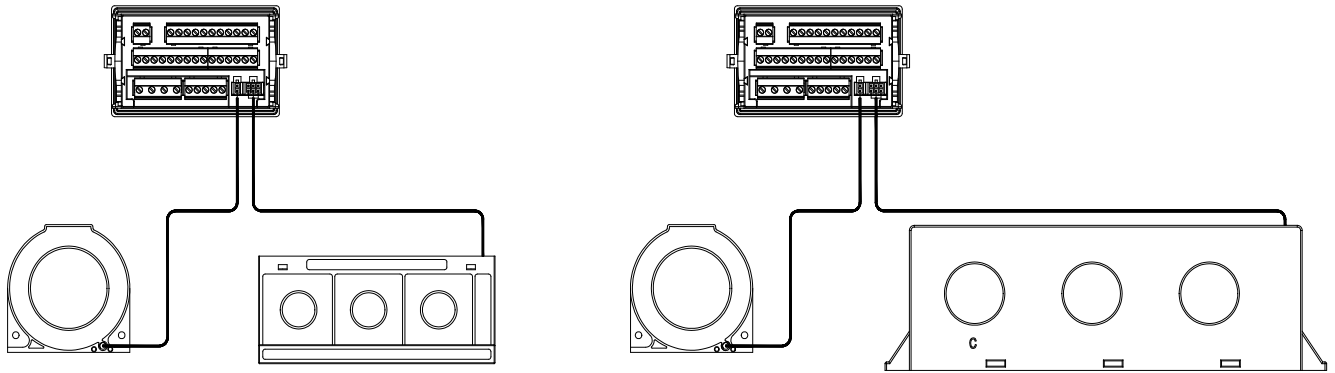

100A及以下电流规格

100A and below current spec

250A、800A电流规格

250A and 800A current spec

图2 分体式保护器产品组成

Figure2 The composition of split protector

5.2 外形与开孔尺寸 (单位: mm) Panel size and opening(Unit:mm)

外形与开孔尺寸如图3、4所示:

The shape and opening size are shown in Figure3,4:

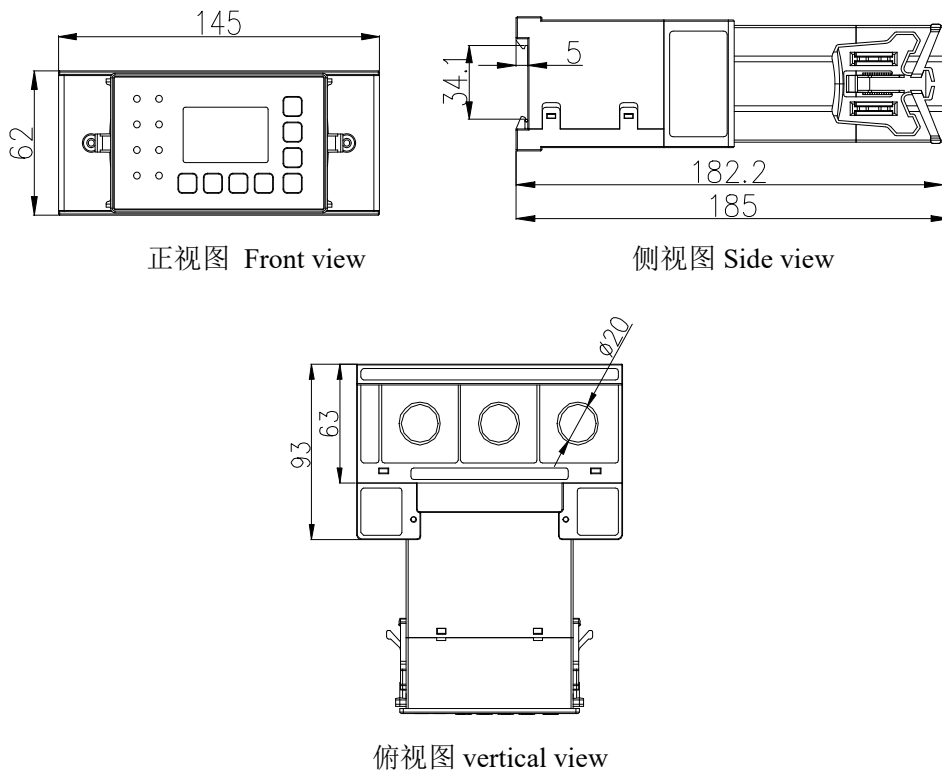

正视图 Front view

侧视图 Side view

俯视图 vertical view

图3 ARD2M 一体式电动机保护器外形尺寸

Figure 3 Panel size of integrated protector ARD2M



图 4 ARD2M 分体式电动机保护器外形与开孔尺寸

Figure 4 Panel size of split protector ARD2M

5.3 互感器安装尺寸 (单位: mm) Size of installation of current transformer(unit:mm)

5.3.1 一体式互感器/分体式互感器(100A 及以下电流规格用)外形尺寸如图 5 所示

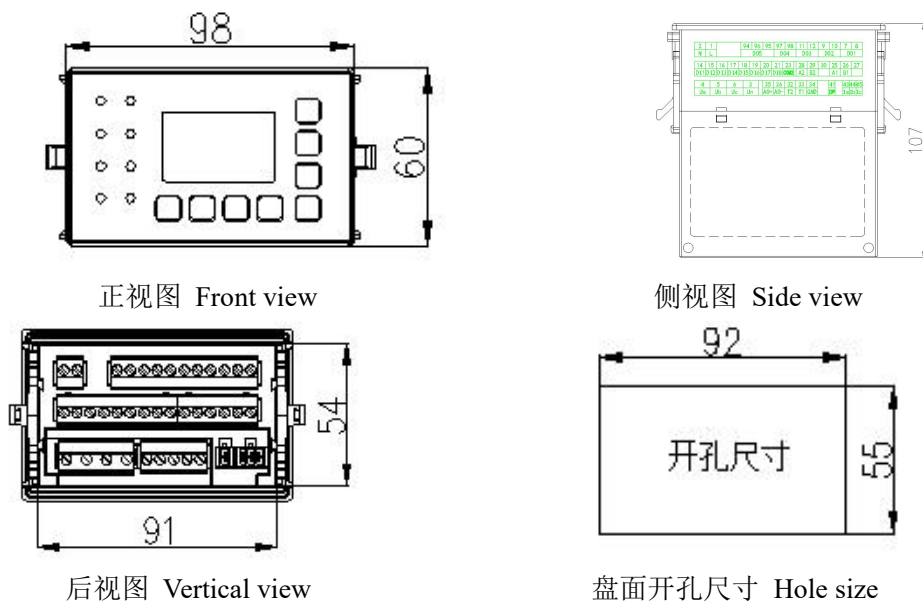
(单位: mm):

The external dimensions of Integrated/split current transformer(100A and below current specification)are shown in figure 5(Unit:mm):



图 5 一体式互感器/分体式互感器(100A 及以下电流规格用)外形尺寸

Figure 5 The external dimensions of Integrated/split current transformer(100A and below current specification)

5.3.2 分体式互感器(250A、800A 电流规格)外形尺寸如图 6 所示 (单位: m):

The external dimensions of split current transformer(250A and 800A current specification)are shown in figure

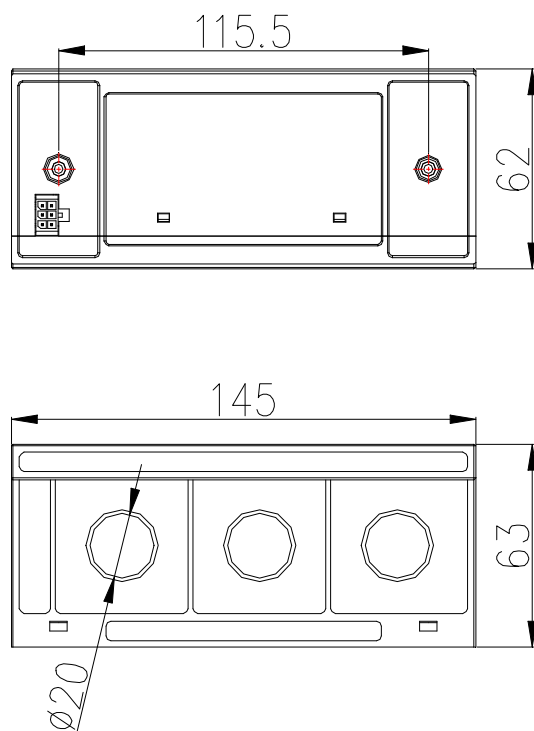
6(Unit:mm):



图 6 分体式互感器(250A、800A 电流规格用)外形尺寸

Figure 6 The external dimensions of split current transformer(250A and 800A current specification)

5.3.3 漏电流互感器外形尺寸如图 7、表 6 所示（单位：mm）：

The external dimensions of leakage current transformer are shown in figure 7 and table 6(Unit:mm):

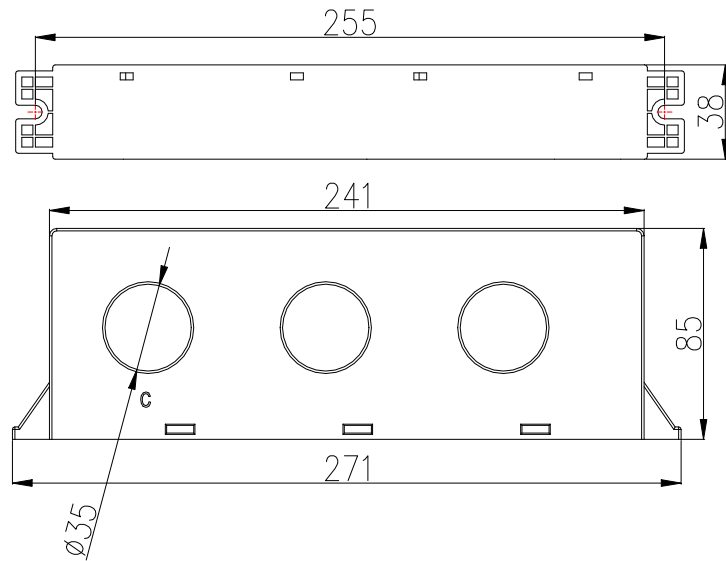

图 7 漏电流互感器外形尺寸

Figure 7 The external dimensions of leakage current transformer

漏电流互感器引出线为双芯屏蔽线，标配长度为 $2m \pm 10cm$ ，客户可根据需要定制。选配漏电(L)功能时，一台保护器配一只互感器。

The leakage transformer is equipped with a secondary wire of $2m \pm 10cm$. If other lengths are needed, please contact the manufacturer, one protector with one transformer.

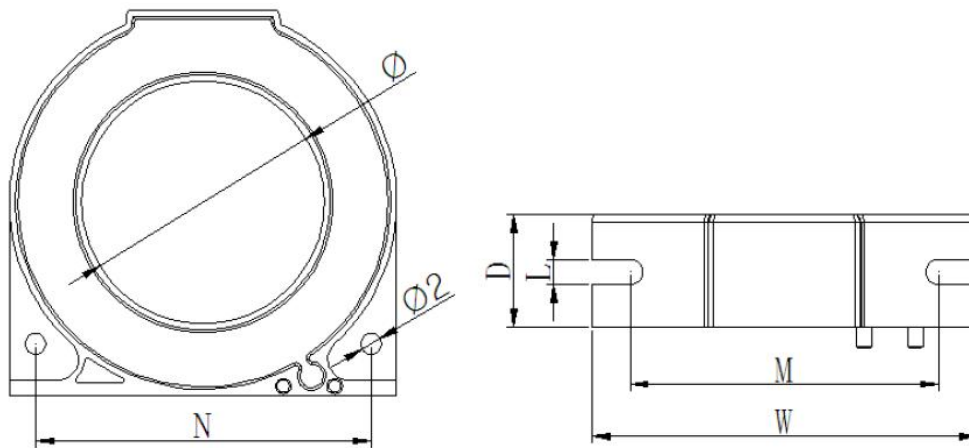
表 6 Table 6

规格 Spec	外形尺寸 Overall size (mm)			穿孔尺寸 Go through size(mm)	安装尺寸 Installation size(mm)				公差 Tolerance (mm)	重量 Weight (g)
	W	H	D	Φ	M	N	L	$\Phi 2$		
L-45	75	75	22	46	65	65	4.3	4	± 1	200 ± 10

L-80	120	120	23	81	105	105	4.4			380± 10
L-100	140	140	23	100	124	124	4.6			460± 10

5.4 接线端子 Wiring terminal

ARD2M 功能分布排列如图 8 所示:

The wiring terminal arrangement of the ARD2M main body is shown in Figure 8 and 9

2	1			94	96	95	97	98	11	12	9	10	7	8	
N	L			D05			D04		D03		D02		D01		
14	15	16	17	18	19	20	21	23	28	29	30	25	26	27	
DI1	DI2	DI3	DI4	DI5	DI6	DI7	DI8	COM2	A2	B2		A1	B1		
4	5	6	3		35	36	32	33	34		41		43	44	45
Ua	Ub	Uc	Un		A0+	A0-	T2	T1	GND		I0*		Ia	Ib	Ic

图 8 CP 端子排列图

Figure 8 The wiring terminal arrangement of ARD2M CP

2	1			94	96	95	97	98	11	12	9	10	7	8	
N	L			D05			D04		D03		D02		D01		
14	15	16	17	18	19	20	21	23	28	29	30	25	26	27	
DI1	DI2	DI3	DI4	DI5	DI6	DI7	DI8	COM2	B2	A2		A1	B1		
4	5	6	3		35	36	32	33	34		41		43	44	45
Ua	Ub	Uc	Un		A0+	A0-	T2	T1	GND		I0*		Ia	Ib	Ic

图 9 CC 端子排列图

Figure 9 The wiring terminal arrangement of ARD2M CC

ARD2M 端子号与功能定义见表 7:

See Table 7 for the ARD2M terminal number and function definition:

表 7 Table 7

端子号 Terminals NO.	功能定义 Function definition	备注 Remark
1	电源输入 L (直流时为+) Power input L (+ at DC time)	辅助电源接入此两端子 The auxiliary power supply is connected to the two terminals
2	电源输入 N (直流时为-) Power input N (- at DC time)	
3	Un 输入 Un input	三相电压输入 Three-phase voltage input
4	Ua 相电压输入 Ua Phase voltage input	
5	Ub 相电压输入 Ub Phase voltage input	
6	Uc 相电压输入 Uc Phase voltage input	

7、8	DO1, 起动 1 输出 DO1,Start 1 output	5 路可编程继电器输出 (DO) (功能定义为出厂默认设置, 用户可根据需要自行设置) 5-channel programmable relay output (DO)(The function is defined as factory default setting, which can be set by users according to their needs)
9、10	DO2, 起动 2 输出 DO2,Start 2 output	
11、12	DO3, 报警输出 DO3,Alarm output	
97、98	DO4, 脱扣输出, 常开点信号 DO4,Trip output, normally open point signal	
94、95、96	DO5, 带公共端的常开+常闭脱扣输出 DO5,Trip output, normally closed+normally open with common end	
14	DI1, 停车信号输入 DI1,Stop signal input	
15	DI2, 起动 1 信号输入 DI2,Start 1 signal input	
16	DI3, 起动 2 信号输入 DI3,Start 2 signal input	
17	DI4, 紧急停车信号输入 DI4,Emergency stop signal input	
18	DI5, 复位信号输入 DI5,Reset signal input	
19	DI6, 控制权限 1 输入 DI6,Control permission 1 input	
20	DI7, 控制权限 2 输入 DI7,Control permission 2 input	
21	DI8, 外部故障输入 DI8,External fault signal input	
23	COM2, DI 输入公共端 COM2,DI Input common terminal	
35	模拟量输出 AO+ Analog output AO+	1 路 4-20mA 模拟量输出 1 channel 4-20mA analog output
36	模拟量输出公共端 AO- Analog output common end AO-	
25	A1	第一路 Modbus-RTU 通讯 First channel MODBUS communication
26	B1	
28	A2	第二路 Profibus-DP 通讯 Second channel MODBUS communication
29	B2	
32	T2 (PTC 输入 B) T1(PTC input A)	温度保护 (热敏电阻输入) Temperature protection (thermistor input)
33	T1 (PTC 输入 A) T2(PTC input B)	
34	GND	
41	IO*漏电流输入 IO*leakage current input	漏电流输入 Leakage current input
43	Ia 相电流输入 Ia Phase current input	
44	Ib 相电流输入 Ib Phase current input	
45	Ic 相电流输入 Ic Phase current input	

注: 第二路 Modbus-RTU 通讯时, 端子号 28 为 B2, 29 为 A2。

Note: When the second channel communication, the terminal 28 is B2, the terminal 29 is A2.

6、保护功能说明 Protection function description

各项保护默认作用阶段见表 8:

The default action stages of each protection are shown in Table 8:

表 8 Table 8

保护类型 Protection type	默认起作用时段 Default active period
-------------------------	----------------------------------

过压、欠压、电压不平衡、相序、外部故障、溢出保护、起动次数、故障次数、运行时间、PTC/NTC 温度保护 Overvoltage, undervoltage, voltage imbalance, phase sequence, external fault, overflow protection, starting times, fault times, running time, PTC/NTC temperature protection	全程 whole course
反时限过载、堵转、断相、漏电、接地、起动超时、短路、溢出保护、过压、欠压、电压不平衡、相序、外部故障、起动次数、故障次数、运行时间、PTC/NTC 温度保护、定时限过载 starting timeout, short circuit, overflow protection, Overvoltage, undervoltage, voltage imbalance, phase sequence, external fault, number of starts, number of faults, running time, PTC/NTC temperature protection, fixed time overload	起动中 When starting
反时限过载、阻塞、断相、电流不平衡、漏电、接地、定时限过载、欠载、短路、溢出保护、过压、欠压、电压不平衡、相序、欠功率、过功率、外部故障、PTC/NTC 温度保护、起动次数、故障次数、运行时间 Reverse time-limit overload, blocking, phase break, current imbalance, leakage, grounding, constant time-limit overload, underload, short circuit, overflow protection, overvoltage, undervoltage, voltage unbalance, phase sequence, underpower, overpower, external fault, PTC/NTC temperature protection, number of starts, number of faults, running time	运行中 In operation

6.1 反时限过载保护 Inverse time overload protection

当电动机在过负载情况下，长时间超过其额定电流运行时，会导致电动机过热，绝缘降低而烧毁，保护器根据电动机的发热特性，计算电动机的热容量，模拟电动机发热特性对电动机进行保护。

When the motor runs for a long time in excess of its rated current under excessive load, it will overheat the motor, reduce insulation and burn it out. The protector calculates the heat capacity of the motor according to its heating characteristics and simulates its heating characteristics to protect the motor.

反时限过载保护起动条件为三相电流最大值达到设定的过载起动定值，默认过载起动定值为 1.2 倍电动机额定电流。

The starting condition of reverse time-limit overload protection is that the maximum three-phase current reaches the set overload starting value, and the default overload starting value is 1.2 times the motor's rated current.

过载保护电流-时间对照表见表 9，过载特征曲线图（K 曲线图）见图 10 所示：

The current-time comparison table of overload protection is shown in Table 9, and the overload characteristic curve (K curve) is shown in Figure 9:

表 9 Table 9

可选的脱扣曲线等级 K Optional tripping curve grade K	1	2	3	5	10	15	20	25	30	35	40
脱扣延时 (S) 误差 $\pm 10\%$ Tripping delay(S) tolerance $\pm 10\%$	三相平衡的负载，自冷态始 Three - phase balanced load, starting from the cold state										
额定值 $I_e \times 1.2$	25	50	75	125	250	375	500	625	750	875	100

Rated value $I_e \times 1.2$											0
$\times 1.5$	16	32	48	80	160	240	320	400	480	560	640
$\times 2$	9	18	27	45	90	135	180	225	270	315	360
$\times 3$	4	8	12	20	40	60	80	100	120	140	160
$\times 4$	2.26	4.52	6.78	11.3	22.5	33.8	45	56.3	67.5	78.8	90
$\times 5$	1.44	2.88	4.32	7.2	14.4	21.6	28.8	36	43.2	50.4	57.6
$\times 6$	1	2	3	5	10	15	20	25	30	35	40
$\times 7.2$	0.7	1.4	2.1	3.5	6.9	10.4	13.9	17.4	20.8	24.3	27.8



图 10 过载特征曲线图 (K 曲线图)

Figure 10 Characteristic curve of overload (K curve)

反时限过载保护可提高手动和自动两种复位方式选择。选择“自动”时，在电动机过载脱扣后，热容量降到 15%以下自动复位，不需要再进行复位操作即可允许再次起动操作；选择“手动”时，在电动机过载脱扣后，热容量降到 15%以下，需要人工手动复位，否则不允许再次起动操作。

Inverse time overload protection improves manual and automatic reset options. When "automatic" is selected, after the overload trip of the motor, the heat capacity will be automatically reset to less than 15%, and the restart operation can be allowed without the need for further reset operation; When "manual" is selected, after the motor overload trip, the heat capacity will be reduced to less than 15%. Manual manual reset is required, otherwise the restart operation is not allowed.

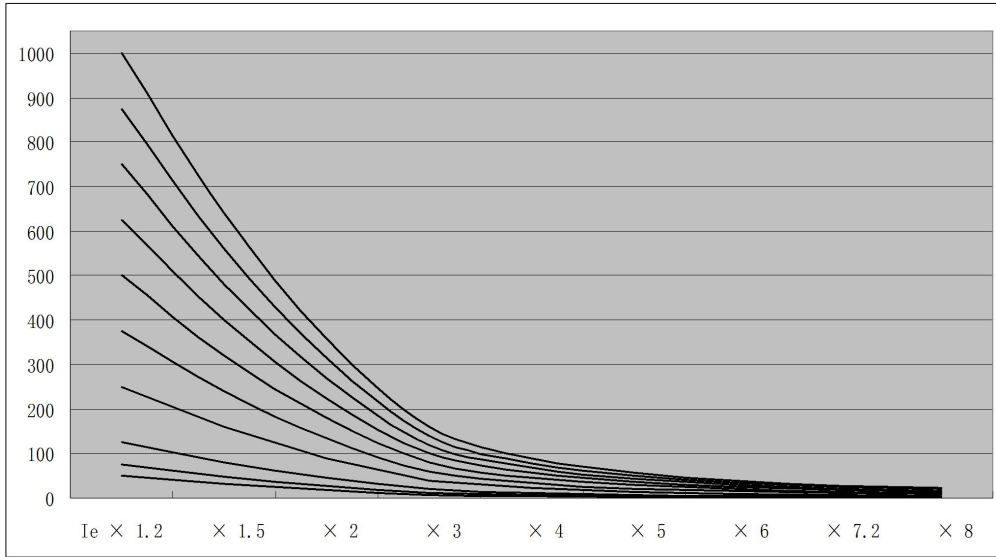
反时限过载保护逻辑框图 Logic block diagram of anti-time overload protection

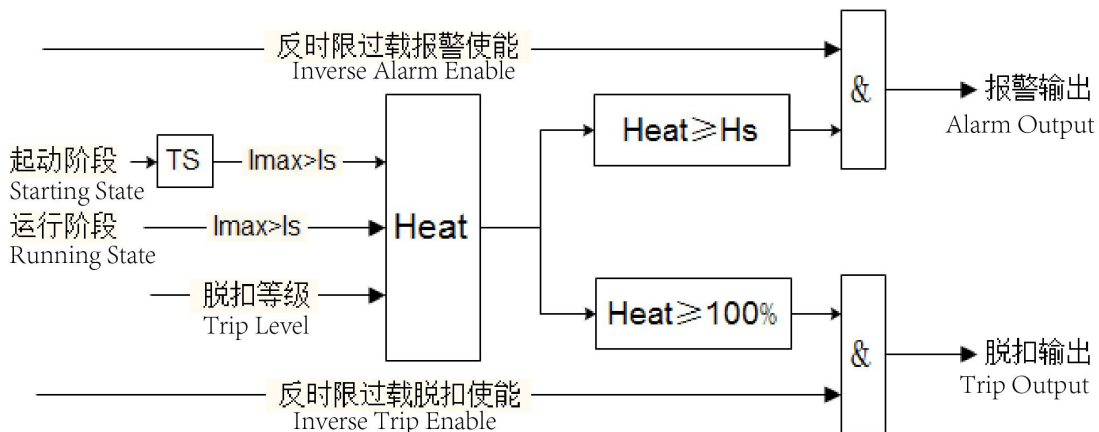

注 Note:

I_{max} : 三相电流最大值 Maximum three-phase current

I_s : 过载起动定值 Overload starting fixed value

Heat: 热容量百分比 Percentage heat capacity

H_s : 热容量报警值 Heat capacity alarm value

TS: 起动屏蔽时间 Starting shield time

t_E 时间保护 t_E Time protection

对于增安型电动机，交流绕组在最高环境温度下达到额定运行稳定温度后，从开始通过堵转电流时记起，直至上升到极限温度所需的时间即为 t_E 时间。增安型电机的 t_E 时间通常由电机制造商提供，用户可以在电机铭牌上找到该数据。

For the increased safety type motor, after the ac winding reaches the rated operating stable temperature at the highest ambient temperature, the time required from the beginning of passing through the blocking current until it rises to the limit temperature is t_E time. The t_E time of the increased safety motor is usually provided by the motor manufacturer, and the user can find this data on the motor nameplate.

提供堵转时在 t_E 时间内断开电动机电源的热过载保护，仅在电动机起动完成后投入，带有独立的延时计时器。 t_E 保护特征曲线动作延时对照表见表 10，曲线图如图 11 所示：

It provides thermal overload protection of disconnecting the power supply of the motor within t_E time during lock-in. It is only put in after the motor is started, with an independent delay timer. The motion delay comparison of t_E protection characteristic curve is shown in Table 10, and the curve is shown in Figure 11:



图 11 t_E 保护延时与堵转电流比 I_A/I_e 的电流—时间特性曲线

Figure 11 t_E Protection delay to blocking current ratio I_A/I_e Current-time characteristic curve

说明 Instructions:

t_{Ep} : 7 倍额定电流时允许堵转时间; 7 times of the rated current allowed lock-in time;

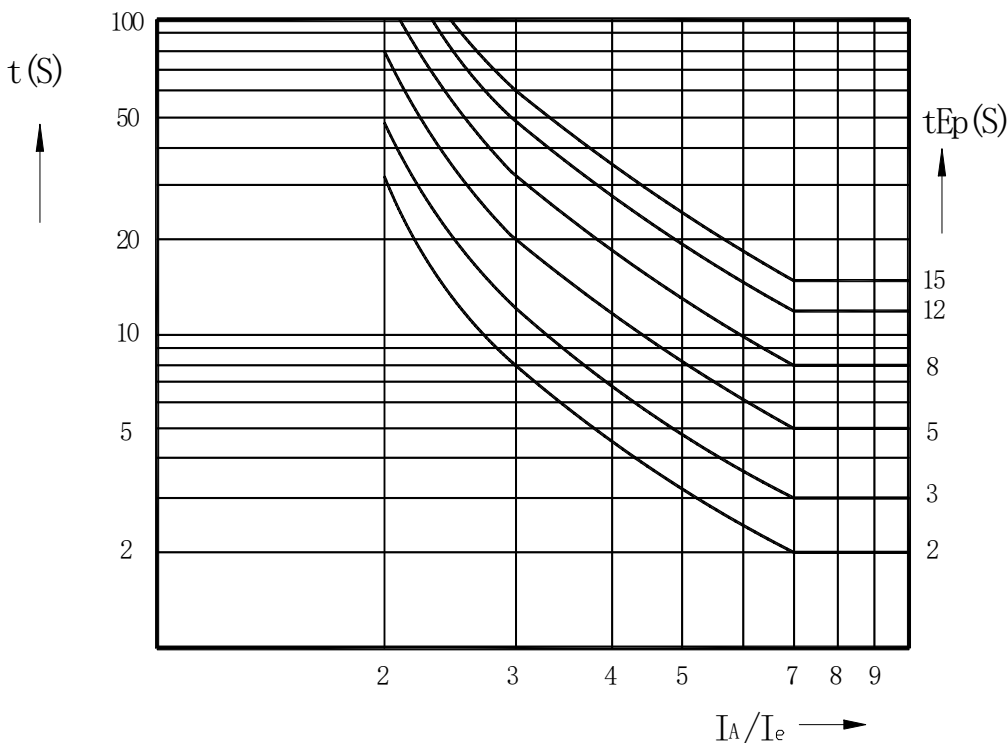
I_A : 堵转电流; Locked-rotor current;

I_e : 电动机额定电流。Rated current of the motor.

表 10 Table 10

t _{Ep} 设定 IA/Ie t _{Ep} Set IA/Ie	2 (S)	3 (S)	4 (S)	5 (S)	6 (S)	8 (S)	10 (S)	12 (S)	15 (S)
2.0	32	48	64	80	96	128	160	192	240
2.2	20.27	30.4	40.54	50.67	60.81	81.08	101.35	121.62	152.02
2.4	14.75	22.12	29.5	36.87	44.25	59	73.75	88.5	110.63
2.6	11.54	17.32	23.09	28.87	34.64	46.19	57.74	69.29	86.62
2.8	9.46	14.19	18.92	23.65	28.39	37.85	43.31	56.78	70.97
3.00	8	12	16	20	24	32	40	48	60
3.20	6.91	10.37	13.83	17.29	20.75	27.67	34.59	41.51	51.88
3.40	6.08	9.13	12.17	15.22	18.26	24.35	30.44	36.52	45.66
3.60	5.43	8.14	10.86	13.58	16.29	21.72	27.16	32.59	40.74
3.80	4.9	7.35	9.8	12.25	14.7	19.6	24.5	29.41	36.76
4.00	4.46	6.69	8.93	11.16	13.39	17.86	22.32	26.79	33.48
4.20	4.09	6.14	8.19	10.24	12.29	16.39	20.49	24.59	30.74
4.40	3.79	5.68	7.58	9.47	11.37	15.06	18.95	22.74	28.42
4.60	3.52	5.28	7.05	8.81	10.57	14.1	17.62	21.15	26.43
4.80	3.29	4.94	6.59	8.24	9.88	13.08	16.48	19.77	24.72
5.00	3.09	4.64	6.19	7.74	9.29	12.38	15.48	18.58	23.22
5.20	2.92	4.38	5.84	7.3	8.76	11.68	14.6	17.53	21.91
5.40	2.76	4.15	5.53	6.91	8.3	11.07	13.83	16.6	20.75
5.60	2.63	3.94	5.26	6.57	7.89	10.52	13.15	15.78	19.73
5.80	2.5	3.76	5.01	6.27	7.52	10.03	12.54	15.05	18.81
6.00	2.4	3.6	4.8	6	7.2	9.6	12	14.4	18
6.20	2.3	3.45	4.6	5.75	6.9	9.2	11.51	13.81	17.26
6.40	2.21	3.32	4.42	5.53	6.64	8.85	11.07	13.28	16.6
6.60	2.13	3.2	4.27	5.33	6.4	8.54	10.67	12.81	16.01
6.80	2.06	3.09	4.12	5.16	6.19	8.25	10.32	12.38	15.48
7.00	2	3	4	5	6	8	10	12	15
8.00	2	3	4	5	6	8	10	12	15
9.00	0.2	0.2	0.2	0.2	0.2	0.2	0.2	0.2	0.2

注 Note:

(1)、t_E 保护的動作時間=t_{Ep} 為 2 (S) 時的動作時間/2×t_{Ep} 設定值

The action time of t_E protection = the action time /2×t_{Ep} when t_{Ep} is 2 (S)

(2)、t_E 設定為 5 (S) 時，按起動電流比 IA/Ie 確定的 t_E 值是按照 IEC79-7、GB3836.3-2000 標準，在用於增安型電動機 t_E 時間保護時，其反時限過載保護可參照該特性曲線設定。為確保電動機堵轉時在 t_E 時間前斷開電源，過載保護裝置的反時限曲線宜下移 15% 左右。

When t_E is set at 5 (S), the t_E value determined according to the starting current ratio IA/ Ie is in accordance with IEC79-7 and GB3836.3-2000 standards. When it is used for t_E time protection of increased safety motor, its inverse time overload protection can be set according to this characteristic curve. In order to ensure that the power is disconnected before t_E time during the motor's lock-in, the inverse time curve of the overload protection device should be lowered by

about 15%.

(3)、 t_E 保护的動作时间是通过设定“电机类型”和“脱扣等级”来实现的，根据表 10 设定 t_{Ep} (脱扣等级) 来选择相应的脱扣曲线。(当电机类型选择为“增安电机”时，脱扣等级自动变为 t_{Ep} 设定；否则脱扣曲线是普通电机的反时限过载脱扣曲线。)

The action time of t_E protection is achieved by setting "motor type" and "trip level", and the corresponding trip curve is selected by setting t_{Ep} (trip level) according to Table 10.(When the motor type is selected as "increased security motor", the tripping level will automatically change to t_{Ep} setting; Otherwise, the trip curve is the reverse time-limit overload trip curve of ordinary motor.

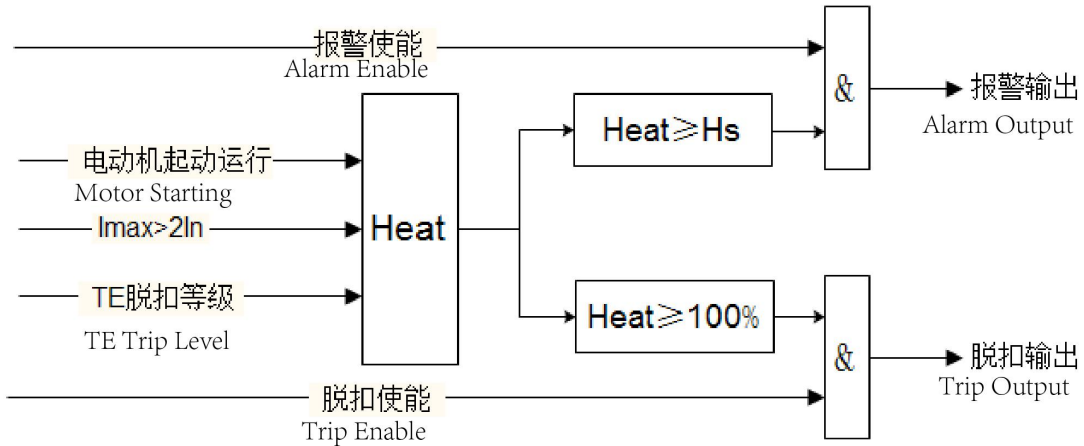

注 Note:

I_{max} : 三相电流最大值 Maximum three-phase current

I_n : 额定电流 Rated current

Heat: 热容量百分比 Percentage heat capacity

H_s : 热容量报警值 Heat capacity alarm value

6.2 起动超时保护 Start timeout protection

当电动机起动时间达到用户设定的起动时间，三相平均电流未下降到设定的脱扣阈值以下，触发起动超时保护，发出脱扣命令，停止电机运行。针对增安电机，起动时间整定不得超过 1.7 倍 t_E 时间。

When the starting time of the motor reaches the starting time set by the user, the average three-phase current does not drop below the set tripping threshold, trigger the starting timeout protection, issue tripping command, and stop the motor operation. For the increased safety motor, the starting time setting shall not exceed 1.7 times t_E time.

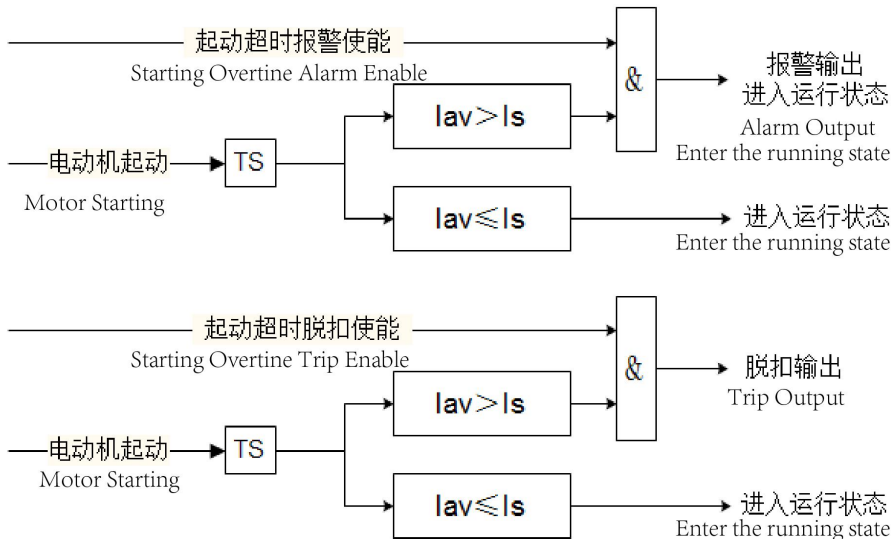

注 Note:

Iav: 三相平均电流 Three-phase mean current

Is: 设定的脱扣阈值 Set trip threshold

TS: 起动时间 Starting time

6.3 堵转保护 Locked-rotor protection

电动机在起动过程中，如果由于负荷过大或自身机械原因，造成电动机轴被卡住，而未及时解除故障，将造成电机过热，绝缘降低而烧毁电机。堵转保护适用于电动机起动阶段发生此类故障时进行保护，当平均电流百分比达到设定阈值时，保护器及时在设定时间内脱扣或报警，避免电机烧毁。

In the process of starting, if the motor shaft is stuck due to excessive load or mechanical reasons, and the fault is not removed in time, the motor will overheat and the insulation will be reduced and the motor will be burned out. The locked-rotor protection is applicable to the motor when such faults occur in the starting stage. When the average current percentage reaches the set threshold, the protector will trip or alarm within the set time in time to avoid the motor burning out.

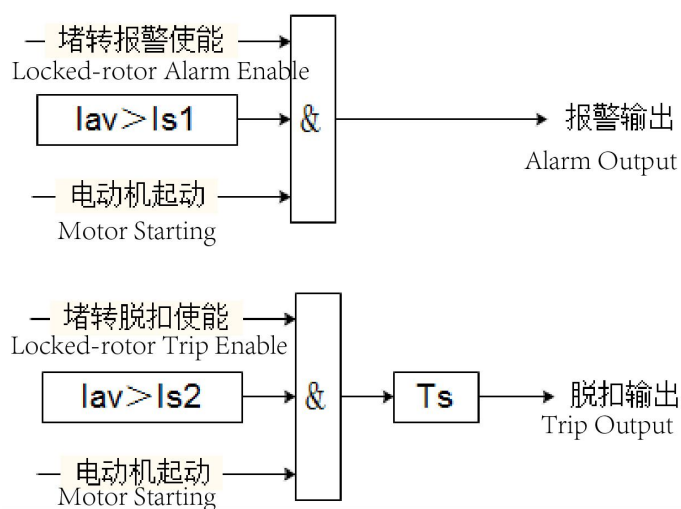

注 Note:

Iav: 三相平均电流 Three-phase mean current

Is1: 报警动作阈值 Alarm action threshold

Is2: 脱扣动作阈值 Tripping threshold

Ts: 脱扣动作延时时间 Delay time of trip action

6.4 阻塞保护 Blocking protection

电动机在运行过程中，如果由于负荷过大或自身机械原因，造成电动机轴被卡住，而未及时解除故障，将造成电机过热，绝缘降低而烧毁电机。阻塞保护适用于电动机运行阶段发生此类故障时进行保护，当平均电流达到设定阈值时，保护器及时在设定时间内脱扣或报警，避免电机烧毁。

During the operation of the motor, if the motor shaft is stuck due to excessive load or mechanical reasons, and the fault is not removed in time, the motor will be overheated and the insulation will be reduced and the motor will be burned out. The blocking protection is applicable to protect the motor when such faults occur in the running stage. When the average current reaches the set threshold, the protector will trip or alarm within the set time in time to avoid the motor burning out.

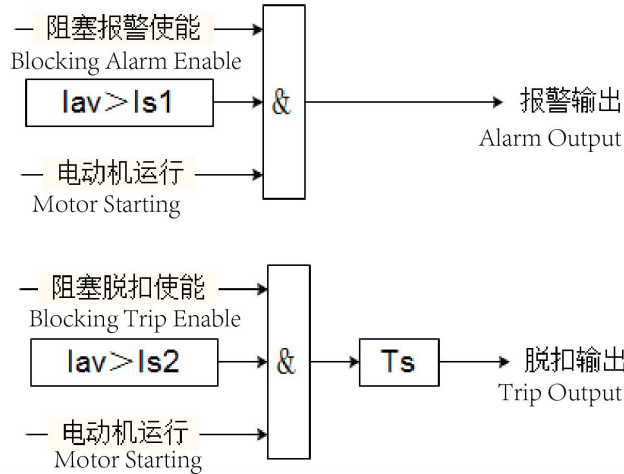

注 Note:

Iav: 三相平均电流 Three-phase mean current

Is1: 报警动作阈值 Alarm action threshold

Is2: 脱扣动作阈值 Trip action threshold

Ts: 脱扣动作延时时间 Delay time of trip action

6.5 欠载保护 Underload protection

当电动机所带负载为泵式负载时，电动机空载或欠载运转会产生危害，保护器提供欠载保护，当三相平均电流低于设定值时，保护器应在设定时间内脱扣或报警。

The protector provides underload protection when the motor is loaded with pumping load. When the average three-phase current is lower than the set value, the protector should trip or alarm within the set time.

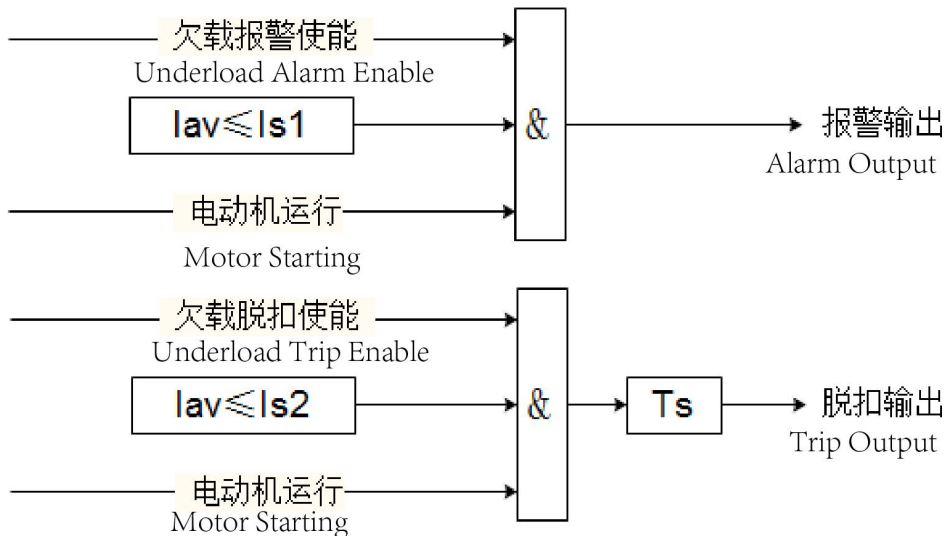

注 Note:

Iav: 三相平均电流 Three-phase mean current

Is1: 报警动作阈值 Alarm action threshold

Is2: 脱扣动作阈值 Trip action threshold

Ts: 脱扣动作延时时间 Delay time of trip action

6.6 欠功率保护 Underpower protection

当负载功率低于设定动作值时，保护器在动作设定时间内脱扣或报警。

When the load power is lower than the set action value, the protector will trip or alarm during the set action time.

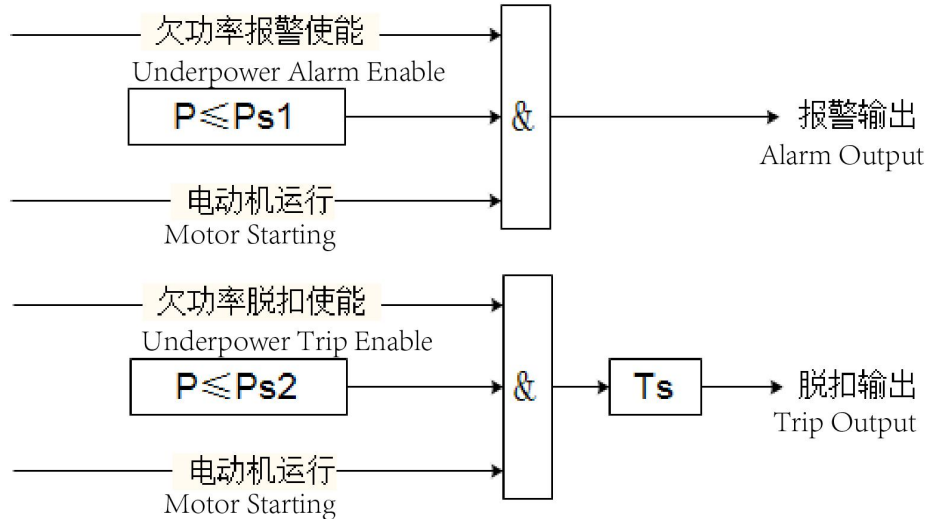

注 Note:

- P: 总有功功率 Total active power
- Ps1: 报警动作阈值 Alarm action threshold
- Ps2: 脱扣动作阈值 Trip action threshold
- Ts: 脱扣动作延时时间 Delay time of trip action

6.7 定时限过载保护 Overload protection

除反时限过载保护外，保护器还可以提供定时限过载保护，当三相的平均电流与额定电流的百分比大于设定值时，保护器应在设定时间内脱扣或报警。

In addition to reverse Overload protection, the protector can also provide time-limit overload protection. When the percentage of three-phase average current and rated current is greater than the set value, the protector should trip or alarm within the set time.

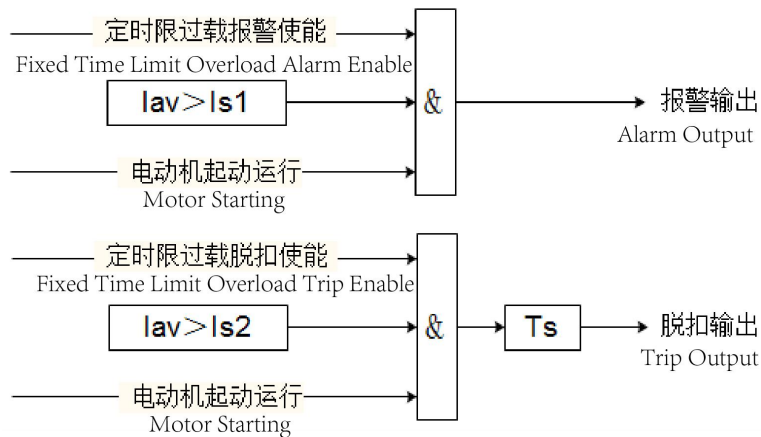

注 Note:

- Iav: 三相平均电流 Three-phase mean current
- Is1: 报警动作阈值 Alarm action threshold
- Is2: 脱扣动作阈值 Tripping action threshold
- Ts: 脱扣动作延时时间 Delay time of trip action

6.8 过功率保护 Overpower protection

当负载功率与额定功率的百分比大于设定动作值时，保护器在动作设定时间内脱扣或报警。

When the percentage of load power to rated power is greater than the set action value, the protector will trip or alarm during the set action time.

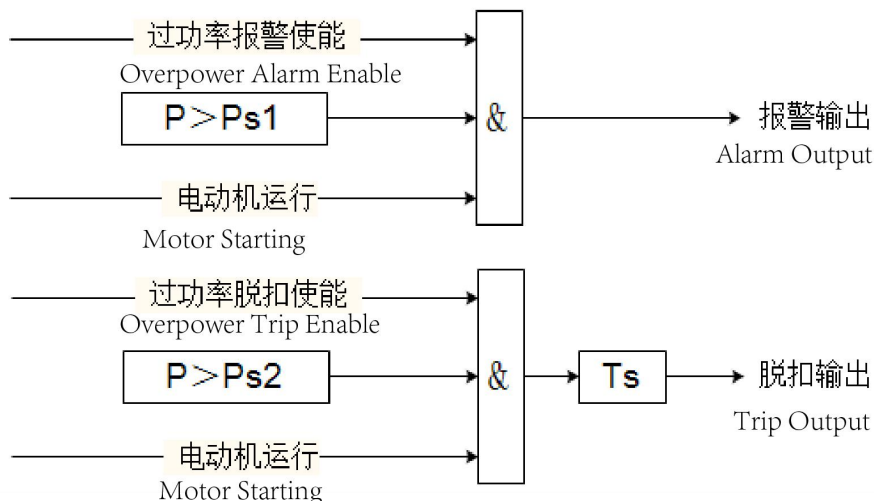

注 Note:

- P: 总有功功率 Total active power
- Ps1: 报警动作阈值 Alarm action threshold
- Ps2: 脱扣动作阈值 Trip action threshold
- Ts: 脱扣动作延时时间 Delay time of trip action

6.9 接地保护 Ground fault protection

保护器根据三相电流矢量和计算接地电流，通过接地电流进行接地保护。接地保护可以设置启动屏蔽时间，在启动屏蔽时间后，当接地电流大于设定值时在设定的时间内动作，动作逻辑可以选择跳接触器或者断路器或报警，选择跳断路器时，保护器先跳断路器，200ms 后跳接触器。

The protector is protected by the ground current according to the three-phase current vector and the calculation of the ground current. The grounding protection can set the starting shielding time. After the starting shielding time, when the grounding current is greater than the set value, the action logic can choose the breaker or breaker or alarm. When the breaker is chosen, the protector should first switch the breaker and then switch the contactor after 200ms.

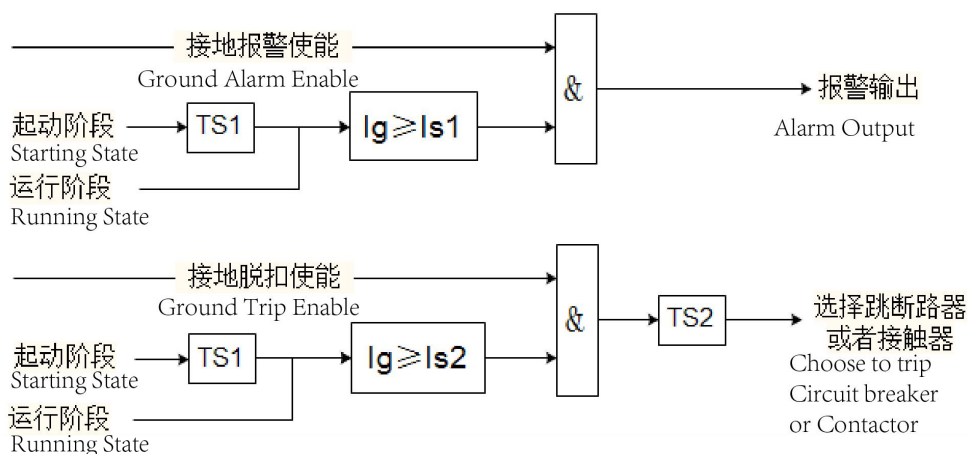

注:

- Ig: 接地电流 Ground current
- Is1: 报警动作阈值 Alarm action threshold
- Is2: 脱扣动作阈值 Tripping threshold
- TS1: 接地启动屏蔽时间 grounding start shielding time
- TS2: 脱扣动作延时时间 Delay time of trip action

6.10 漏电保护 Leakage protection

漏电保护需选配漏电互感器，通过零序互感器检测漏电流。漏电保护可以设置起动屏蔽时间，在起动屏蔽时间后，当漏电流大于设定值时在设定的时间内动作，动作逻辑可以选择跳接触器或者断路器或报警，选择跳断路器时，保护器先跳断路器，200ms 后跳接触器。

Leakage protection should be equipped with leakage current transformer, which can detect the leakage current through the zero-sequence transformer. The leakage protection can set the starting shielding time. After the starting shielding time, when the leakage current is greater than the set value, the operation logic can choose the breaker or breaker or alarm. When the breaker is chosen, the protector should first switch the breaker and then the breaker after 200ms.

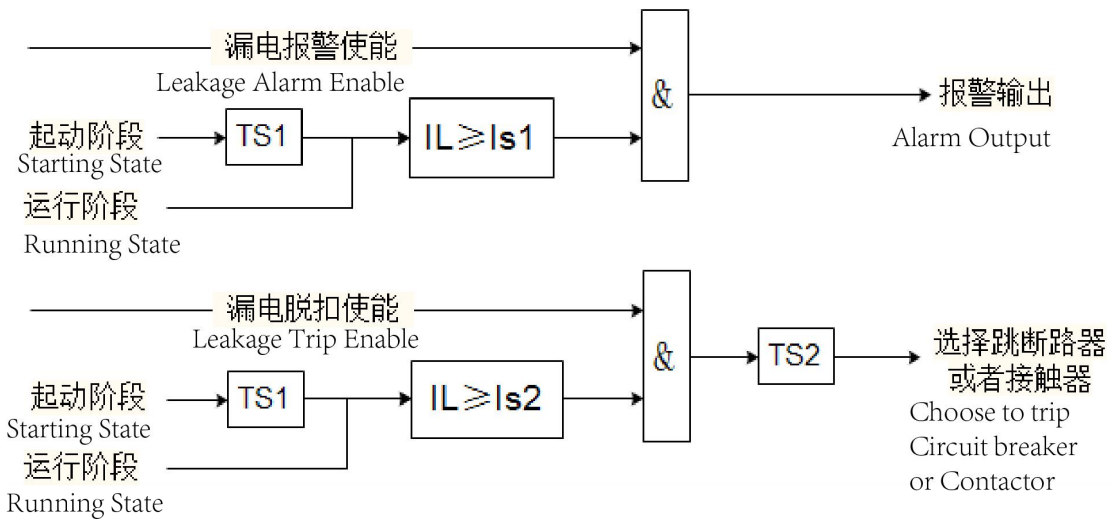

注 Note:

- IL: 漏电流 Leakage current
- Is1: 报警动作阈值 Alarm action threshold
- Is2: 脱扣动作阈值 Tripping threshold
- TS1: 漏电起动屏蔽时间 Shield time of leakage start
- TS2: 脱扣动作延时时间 Delay time of trip action

6.11 电流不平衡保护 I unbalance protection

保护器计算电流不平衡度，当三相电流不平衡度大于设定值时在设定的时间内脱扣或报警。电流不平衡度的计算公式如下：

The protector calculates the current imbalance degree. When the three-phase current imbalance degree is greater than the set value, it will trip or alarm within the set time. The calculation formula of current imbalance degree is as follows:

$$I_{uf} = \left| \frac{I_{\max(\min)} - I_{av}}{I_{av}} \right| \times 100\%$$

其中 I_{uf} 为电流不平衡度， I_{\max} 为电流最大值， I_{\min} 为电流最小值， I_{av} 为平均电流。

Where, I_{uf} is the current imbalance, I_{\max} is the maximum current, I_{\min} is the minimum current, and I_{av} is the average current.

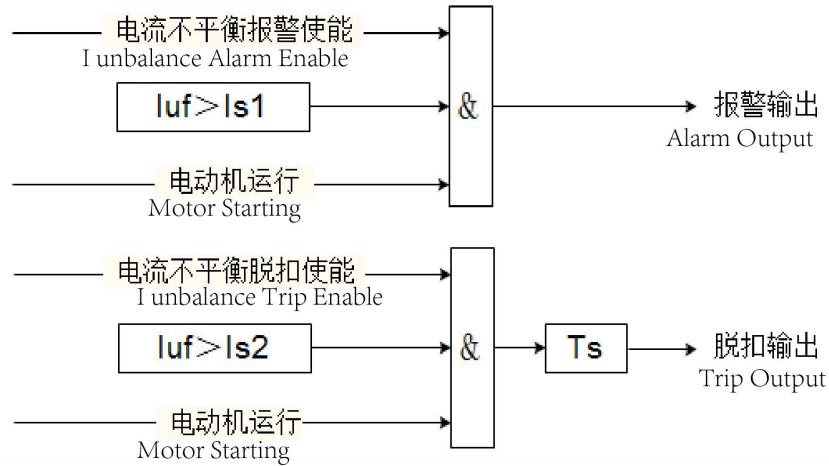

注 Note:

- Iuf: 电流不平衡度 Degree of current imbalance
- Is1: 报警动作阈值 Alarm action threshold
- Is2: 脱扣动作阈值 Tripping action threshold
- Ts: 脱扣动作延时时间 Delay time of trip action

6.12 电压不平衡保护 U unbalance protection

保护器计算电压不平衡度，当电压不平衡度大于设定值时在设定的时间内脱扣或报警。电压不平衡度的计算公式如下：

The protector calculates the voltage unbalance. When the voltage unbalance is greater than the set value, it will trip or alarm within the set time. The calculation formula of voltage imbalance is as follows:

$$U_{uf} = \left| \frac{U_{\max(\min)} - U_{av}}{U_{av}} \right| \times 100\%$$

其中 U_{uf} 为电压不平衡度， U_{\max} 为线电压最大值， U_{\min} 为线电压最小值， U_{av} 为平均线电压。

U_{uf} is the voltage imbalance, U_{\max} is the maximum line voltage, U_{\min} is the minimum line voltage, and U_{av} is the average line voltage.

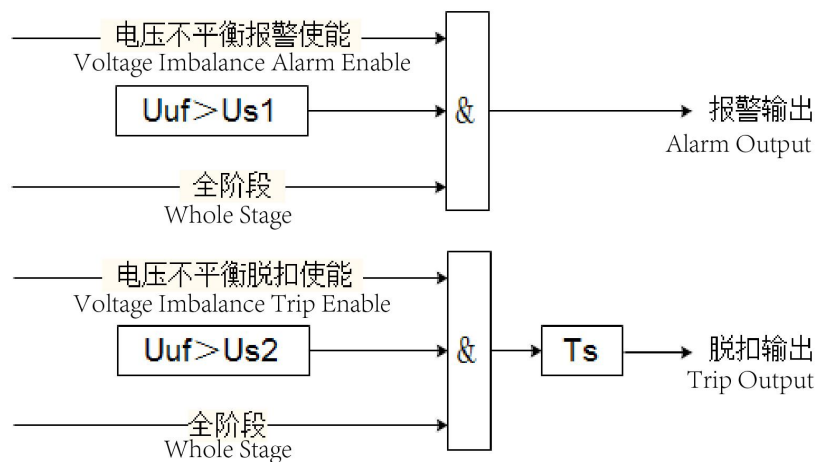

注 Note:

- Uuf: 电压不平衡度 Voltage imbalance degree
- Us1: 报警动作阈值 Alarm action threshold

Us2: 脱扣动作阈值 Trip action threshold

Ts: 脱扣动作延时时间 Delay time of trip action

6.13 断相保护 Phase fail protection

断相故障运行时对电动机的危害很大,当最大电流大于 20%额定电流且最小电流小于 5%额定电流时或者三相电流不平衡度大于 30%时,断相保护在设定的时间内脱扣或报警。

When the phase fault runs, it will do great harm to the motor. When the maximum current is greater than 20% rated current and the minimum current is less than 5% rated current, or when the imbalance degree of three-phase current is greater than 30%, the fault protection will trip or alarm within the set time.

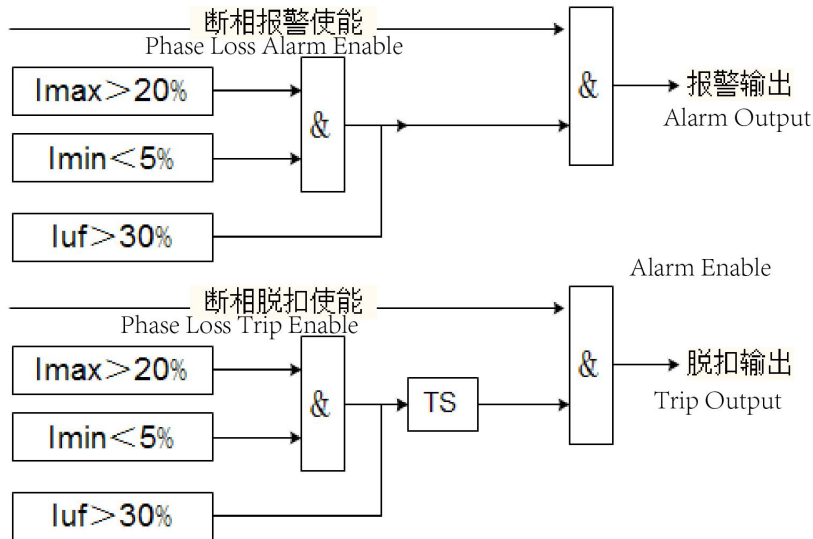

注 Note:

I_{max}: 最大电流 Maximum current

I_{min}: 最小电流 Minimum current

I_{ub}: 电流不平衡度 Degree of current imbalance

TS: 脱扣动作延时时间 Delay time of trip action

6.14 相序保护 Phase sequence protection

当检测到三相电压相序错误时,保护器在设定的时间内脱扣或报警,保护电动机的安全。

When the error of three-phase voltage phase sequence is detected, the protector will trip or alarm within the set time to protect the safety of the motor.

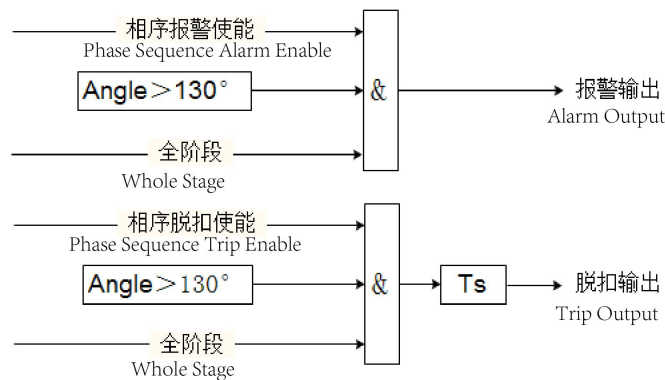

注 Note:

Angle: 任意两相电压的夹角 The Angle between any two - phase voltage

Ts: 脱扣动作延时时间 Delay time of trip action

6.15 过电压保护 Overvoltage protection

电压过高会引起电动机绝缘程度损伤,当电动机最大线电压超过设定值时,保护器在设定时间内脱扣或报警。

Excessive voltage will cause damage to the insulation of the motor. When the maximum line voltage of the motor exceeds the set value, the protector will trip or alarm within the set time.

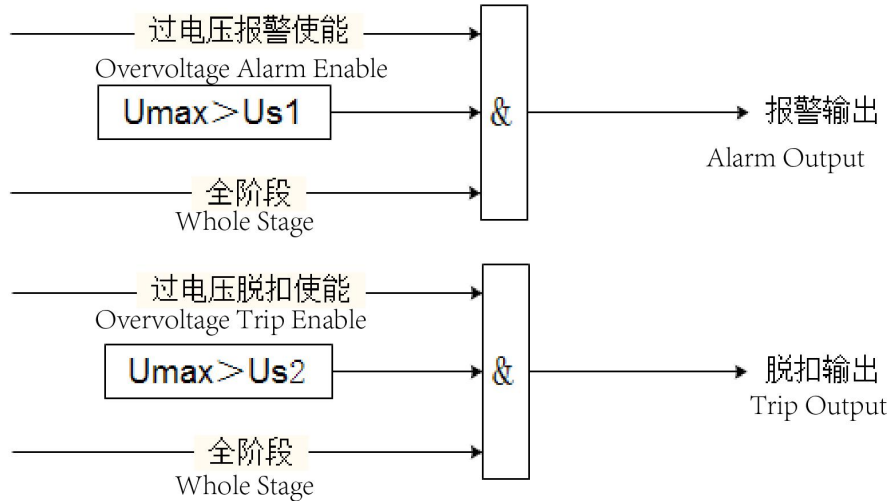

注 Note:

Umax: 最大线电压 Maximum line voltage

Us1: 报警动作阈值 Alarm action threshold

Us2: 脱扣动作阈值 Trip action threshold

Ts: 脱扣动作延时时间 Delay time of trip action

6.16 欠电压保护 Undervoltage protection

电压过低会引起电动机转速降低,甚至停止运行。当电动机最小线电压低于设定值时,保护器在设定时间内脱扣或报警。

Too low voltage will cause the motor to slow down, or even stop running. When the minimum line voltage of the motor is lower than the set value, the protector will trip or alarm within the set time.

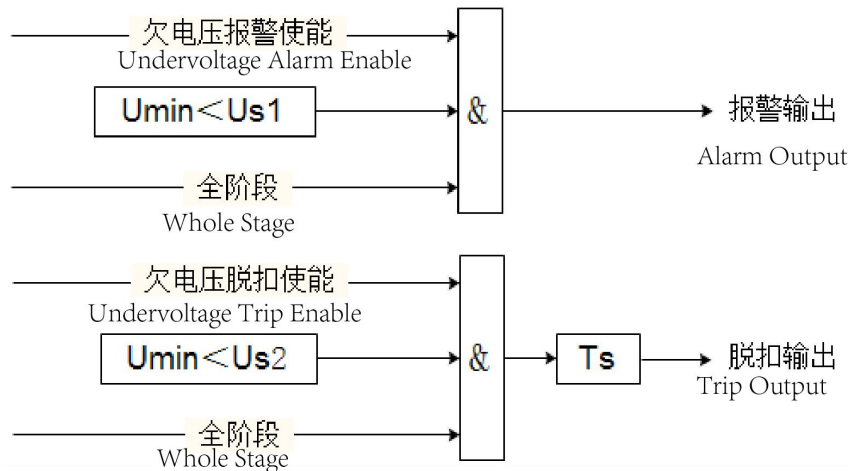

注 Note:

Umin: 最小线电压 Minimum line voltage

Us1: 报警动作阈值 Alarm action threshold

Us2: 脱扣动作阈值 Trip action threshold

Ts1: 脱扣动作延时时间 Delay time of trip action

6.17 短路保护 Short circuit protection

当电动机电流超过设定值时，保护器在设定时间内跳断路器或报警。短路保护分为起动和运行两个阶段，两个阶段的保护参数可独立设置。

When the motor current exceeds the set value, the protector will switch circuit breaker or alarm within the set time. The short circuit protection is divided into two stages: starting and running. The protection parameters of the two stages can be set independently.

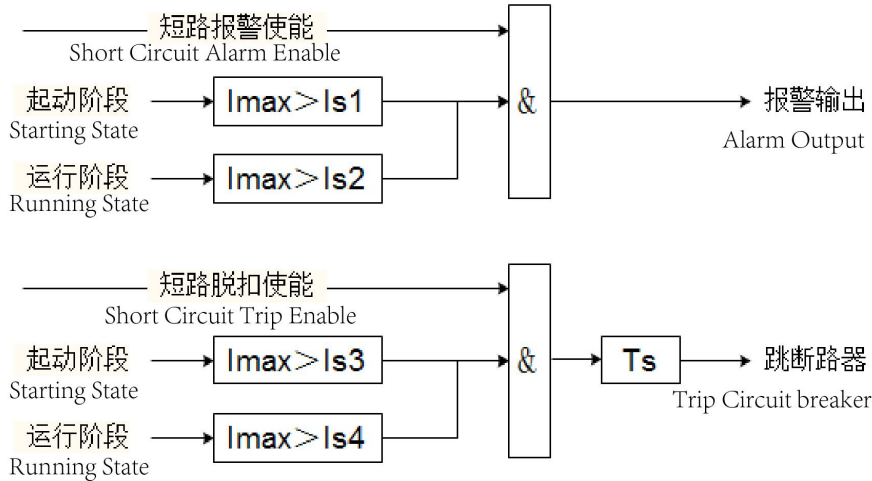

注 Note:

I_{max} : 最大电流 Maximum current

I_{s1} : 起动阶段短路报警动作阈值 Threshold of short circuit alarm during starting stage

I_{s2} : 运行阶段短路报警动作阈值 Threshold of short circuit alarm during operation stage

I_{s3} : 起动阶段短路脱扣动作阈值 Threshold of short-circuit trip during starting stage

I_{s4} : 运行阶段短路脱扣动作阈值 Threshold of short-circuit trip during operation stage

T_s : 脱扣动作延时时间 Delay time of trip action

6.18 温度保护 Temperature protection

温度保护是以预埋在电动机定子绕组或轴承上的热敏电阻值作为保护条件。根据选择的热敏电阻类型不同，保护逻辑不同：热敏电阻为 PTC 时，当检测的电阻值大于设定值时，保护器在设定时间内脱扣或报警；热敏电阻为 NTC 时，当检测的电阻值小于设定值时，保护器在设定时间内脱扣或报警。

Temperature protection is based on the thermistor resistance embedded in the stator windings or bearings of the motor. According to the type of thermistor selected, the protection logic is different: when the thermistor is PTC, when the detected resistance value is greater than the set value, the protector will trip or alarm within the set time; When the thermistor is NTC, when the detected resistance value is less than the set value, the protector will trip or alarm within the set time.

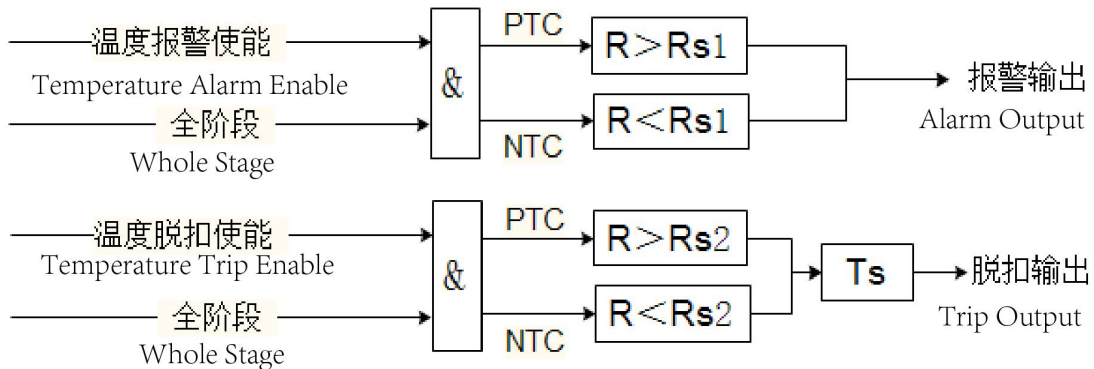

注 Note:

R: 检测温度阻值 Check the temperature resistance

Rs1: 报警动作温度阻值 Resistance value of alarm action temperature

Rs2: 脱扣动作温度阻值 Resistance value of tripping action temperature

Ts: 脱扣动作延时时间 Delay time of trip action

温度保护有手动或自动两种复位方式。选择“自动”时，在温度保护脱扣后，检测到电阻值小于设置的返回阻值后，保护器自动复位；选择“手动”时，在温度保护脱扣后，检测到电阻值小于设置的返回阻值后，需要人工手动复位，否则不允许再次起动。

The temperature protection can be reset manually or automatically. When "Automatic" is selected, the protector will reset automatically after the temperature protection trip when the resistance value is detected to be less than the set return resistance value. When "manual" is selected, after the temperature protection trip, if the resistance value is detected to be less than the set return resistance value, manual manual reset is required, otherwise it will not be allowed to start again.

6.19 外部故障 External fault

当定义为外部故障的开关量输入设置为“常开”时，闭合信号作为故障触发条件，故障信号持续时间长于设定的脱扣/报警延时时间后，产生脱扣/报警；当定义为外部故障的开关量输入设置为“常闭时”，断开信号作为故障触发条件，故障信号持续时间长于设定的脱扣/报警延时时间后，产生脱扣/报警。

When the input of switch quantity defined as external fault is set as "normally on", the closing signal is taken as the trigger condition of the fault. When the duration of the fault signal is longer than the set tripping/alarm delay time, tripping/alarm will be generated. When the input of switch quantity defined as external fault is set as "normally closed", the disconnect signal is used as the trigger condition of the fault. When the duration of the fault signal is longer than the set trip/alarm delay time, trip/alarm will be generated.

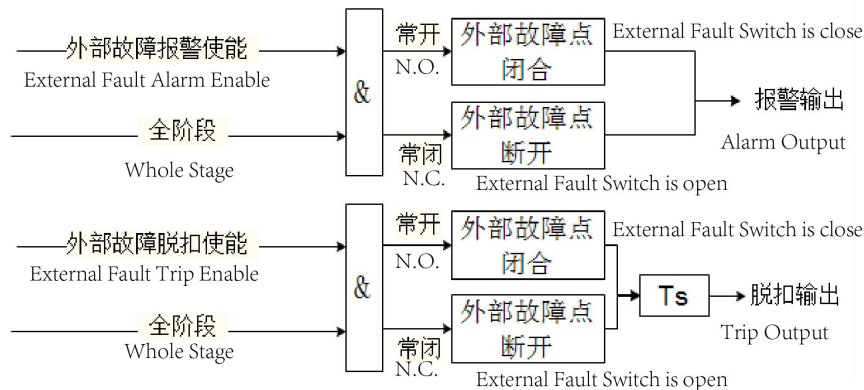

注 Note:

Ts: 脱扣动作延时时间 Delay time of trip action

6.20 溢出保护 Overflow protection

发生故障时电流超过接触器的分断电流，强行断开接触器会损坏接触器。此时应先分断断路器，切除故障电流后再断开接触器。

When the fault occurs, the current exceeds the breaking current of the contactor, and the contactor will be damaged if the contactor is forcibly disconnected. At this point, the breaker should be broken first, and then disconnect the contactor after the fault current is removed.

保护器在产生其它脱扣故障动作前，如果故障电流大于设定的溢出电流，则先跳开断路器，200ms 后再跳开接触器。

If the fault current of the protector is greater than the set overflow current before any other tripping fault action, the breaker should be first switched on, and then the contactor should be switched off after 200ms.

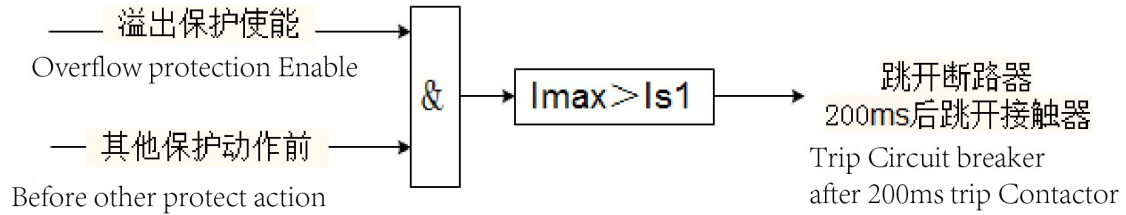

注 Note:

I_{max} : 最大电流 Maximum current

I_{s1} : 溢出电流 Overflow current

6.21 启动次数保护 Number of starts protection

短时间内频繁启停电动机容易造成电动机损坏。当电动机在设置的时间内剩余启动次数为 0 时，保护器发出报警信号，此时若再发出启动命令，则保护器脱扣，需等待冷却时间后允许再次启动。

The motor is easy to be damaged due to frequent starting and cutting in a short time. When the remaining starting number of the motor is 0 within the set time, the protector sends an alarm signal. If the starting command is issued again at this time, the protector will release and allow to start again after the cooling time.

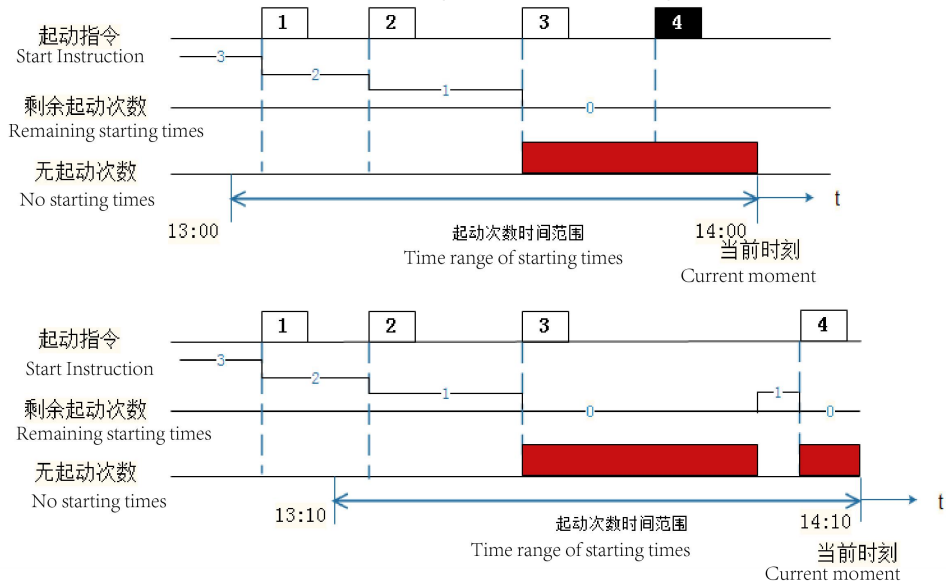

示例 Example:

设置 1 小时时间范围内允许启动 3 次。Set the time limit of 1 hour to allow 3 starts.

上图：13:00-14:00 期间已经启动 3 次，第 4 次时无启动次数，所以第 4 次启动失败。

Figure above: It has been started for 3 times between 13:00 and 14:00, and there is no number of starts at the fourth time, so the fourth time fails.

下图：第 4 次启动前，剩余启动次数恢复至 1 次，所以第 4 次启动成功。

Figure below: Before the fourth start, the remaining number of starts is restored to 1, so the fourth start is successful.

6.22 运行时间报警 Running time alarm

当电动机累计运行时间超过设定值时，保护器发出报警信号，提醒工作人员检修维护电动机。

When the accumulated running time of the motor exceeds the set value, the protector will send an alarm signal to remind the staff to overhaul and maintain the motor.

6.23 故障次数报警 Fault frequency alarm

当保护器累计脱扣保护次数超过设定值时，保护器发出报警信号。

When the cumulative number of protection trips exceeds the set value, the protector will send an alarm signal.

7、功能设置与说明 Display module introduction

7.1 显示模块按键、LED 指示灯说明见表 11:

The display module and LED indicator light are shown in Table11:

表 11 Table 11

序号 Serial No.	名称 Name	状态 State	功能说明 Function Description
1	起动 1 按键 Start 1 button	按下 press	手动模式、两部模式、双速模式、星三角时操作起动 1 继电器 Manual mode, two-part mode, two-speed mode, star triangle operation start 1 relay
2	起动 2 按键 Start 2 button	按下 Press	手动模式、双速模式时操作起动 2 继电器 Operate and start the 2 relay in manual mode and two-speed mode
3	停车按键 Stop button	按下 Press	释放起动继电器 Release starting relay
4	复位按键 Reset button	按下 Press	故障状态时使用, 复归故障 Use in fault state and restore the fault
5	取消按键 Cancel button	按下 Press	退出菜单; 取消操作 Exit menu;Cancel the operation
6	左方向键 Left keys	按下 Press	上翻菜单; 修改数据时数据移位 Upside-down menu;Data is shifted when data is modified
7	右方向键 Right key	按下 Press	下翻菜单; 修改数据 Scroll down menu;Modify the data
8	确认按键 Confirm button	按下 Press	进入设置菜单、写入修改后的数据 Enter the Settings menu and write the modified data
9	就绪 LED 指示灯 Ready LED indicator	亮 Bright	该指示灯亮表示保护器处于正常状态, 可以起动电动机 The indicator light is always on to indicate that the motor is ready to start
10	起动 1 LED 指示灯 Start 1 LED indicator	亮 Bright	该指示灯亮表示保护器起动 1 继电器闭合 When this indicator light is on,it indicate that the Start 1 relay output is closed
11	起动 2 LED 指示灯 Start 2 LED indicator	亮 Bright	该指示灯亮表示保护器起动 2 继电器闭合 When this indicator light is on,it indicate that the Start 2 relay output is closed
12	停车 LED 指示灯 Stop LED indicator light	亮 Bright	该指示灯常亮表示电动机处于停车状态 The indicator light is always on to indicate that the motor is stopped
13	起动 LED 指示灯 Starting LED indicator light	亮 Bright	该指示灯常亮表示电动机处于起动状态 The indicator light is always on to indicate that the motor is in starting state
14	运行 LED 指示灯 Running LED indicator light	亮 Bright	该指示灯常亮表示电动机处于运行状态 The indicator light is always on to indicate that the motor is in running state
15	报警 LED 指示灯 Alarm LED indicator light	亮 Bright	该指示灯亮表示有报警产生 The light indicates an alarm

16	脱扣 LED 指示灯 Trip LED indicator light	亮 Bright	该指示灯亮表示故障脱扣 This indicator light indicates fault trip
----	--	-------------	--

7.2 显示模块简介 Display module introduction

7.2.1 数据显示界面 Data display interface

保护器上电后进入数据显示界面，在此界面下按“←”、“→”键可以进行电流、电压、DI/DO 状态等信息的翻页查看，具体显示内容如图 12（下图为停车状态下的显示数值）：

After the protector is powered on, it enters the data display interface. Press "←" and "→" to scroll through the current, voltage, DI/DO state and other information. The specific display content is shown in Figure 16 (the figure below shows the display value in the stopped state)



图 12 数据显示界面

Figure 12 Data display interface

7.2.2 参数查看与设置 Parameter viewing and setting

需要查看或设置某项参数时，首先按“确认”键进入密码界面，输入正确密码（默认 0001）后进入主菜单。按方向键移动光标至对应选项，按“确认”键进入，选择对应子菜单进行查看或修改。图 13 以修改控制权限作为操作示例：

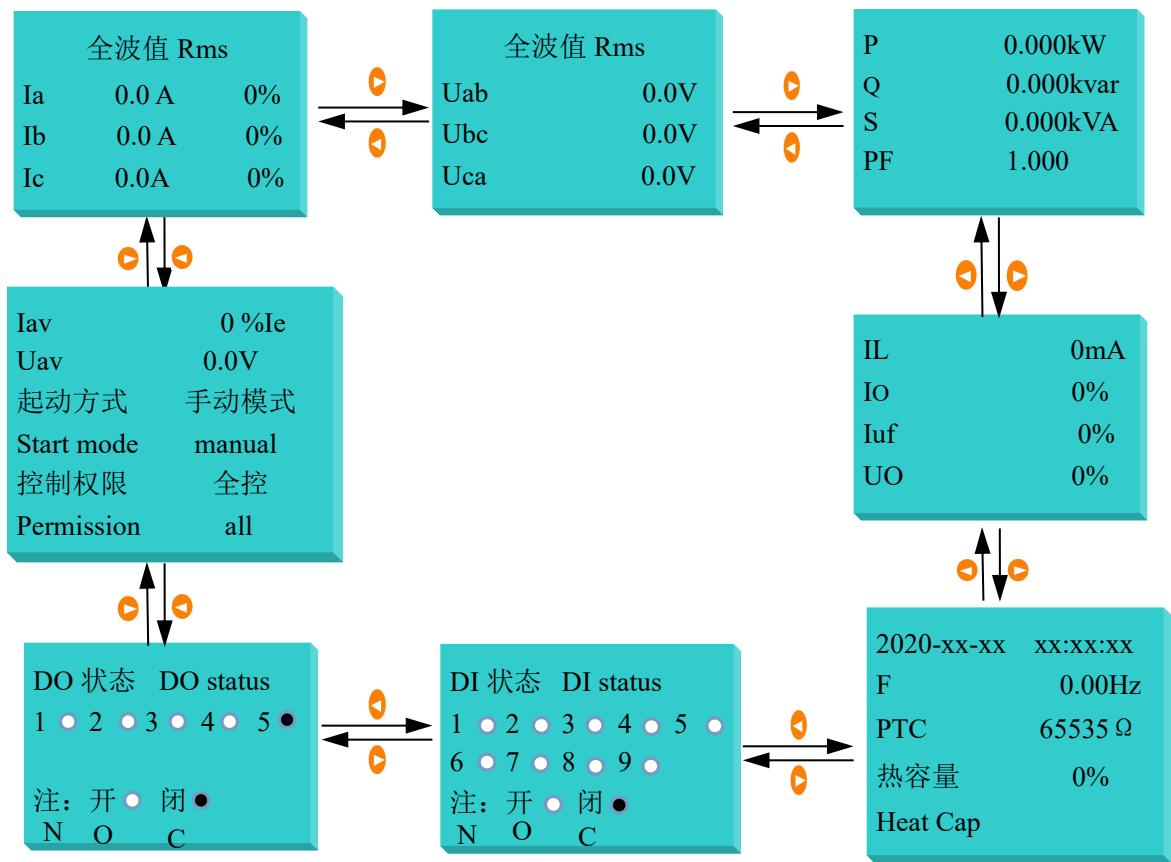
When you need to view or set a parameter, first press "OK" to enter the password interface and enter the correct password (default 0001) before entering the main menu. Press the arrow key to move the cursor to the corresponding option, press the "OK" key to enter, and select the corresponding sub-menu for viewing or modification. Figure 12 shows an example of how to modify the control authority:



图 13 修改控制权限操作示意

Figure 13 Shows the operation diagram of Ethernet communication parameters

7.3 菜单介绍说明 Menu description

ARD2M 菜单介绍见表 12:

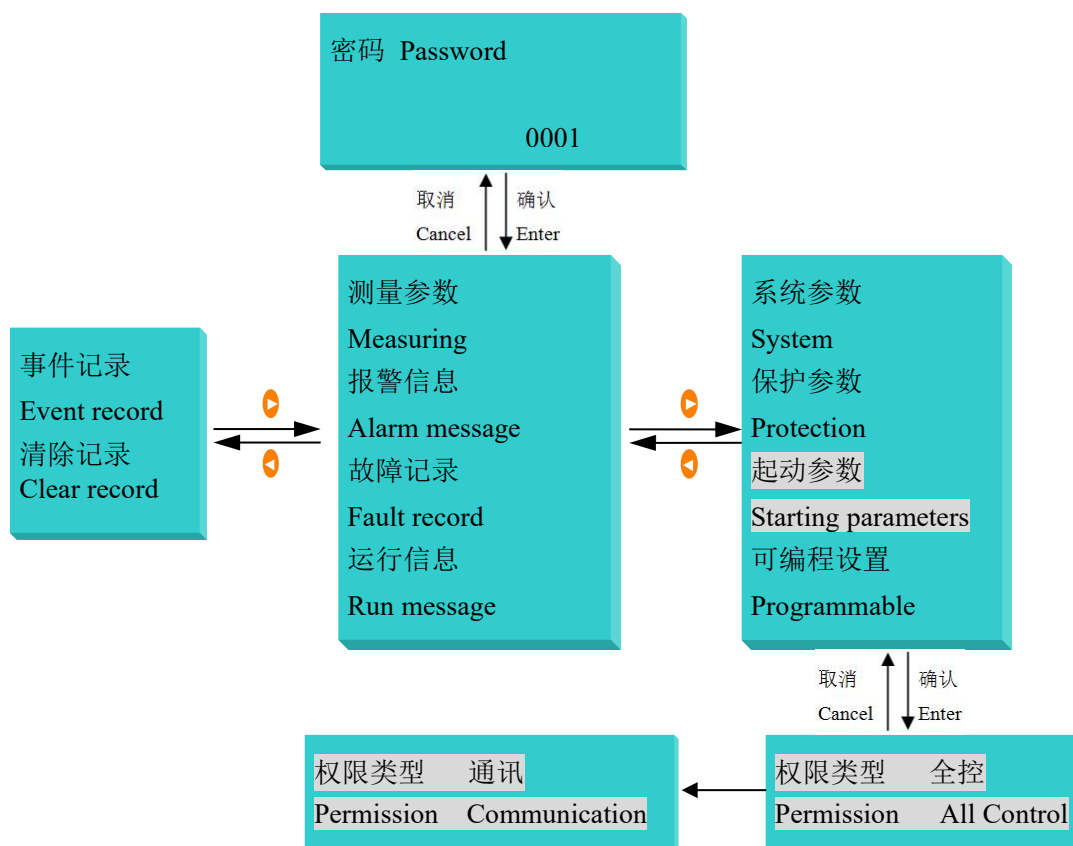
See Table 12 for the ARD2M menu:

表 12 Table 12

序号 Serial No.	主菜单 Main manu	功能 Function	类别 Type	设定范围 Setting Rang	默认值 Default value	单位 Unit
— I	测量参数 Measured parameters	基波电流 Fundamental wave current	—	—	—	A
		有效值电流 Effective current	—	—	—	A
		基波电压 Fundamental wave voltage	—	—	—	V

		有效值电压 RMS voltage	—	—	—	V
		电压相位相角 Voltage phase Angle	—	—	—	
		其他电参量 Other electrical parameters	—	—	—	
二 II	报警信息 Alarm information	—	—	—	—	
三 III	故障记录 Fault record	—	—	—	—	
四 IV	运行信息 Running information	本次运行时间 Running time of this time	—	—	—	h
		本次停车时间 Stop time of this time	—	—	—	h
		总运行时间 Total running time	—	—	—	h
		总停车时间 Total stop time	—	—	—	h
		起动次数 Start qty	—	—	—	
		脱扣次数 Trip qty	—	—	—	
		最大起动电流 Maximum start current	—	—	—	A
		最大运行电流 Maximum running current	—	—	—	A
五 V	系统参数 System parameters	额定电流 Rated current	—	0.1-1.6	1	A
				1.6-6.3	5	
				6.3~25	25	
				25-100	100	
				63~250	250	
		250~800	800			
		额定电压 Rated voltage	—	57-1200V	380	V
		额定功率 Rated power	—	0.12-999kW	—	
		额定频率 Rated frequency	—	45-70	50	Hz
		电机类型 Motor type	—	普通电机、增安电机 Common motor, increased safety motor	普通电机 Common motor,	
		高速电机设置 High speed motor setting	额定电流 Rated current	0.1-1.6	1	
1.6-6.3	5					
6.3~25	25					
25-100	100					
63~250	250					
250~800	800					

		额定功率 ated power	0.12-999kW	—		
		接线方式 Connection mode	—	1P2L、3P3L、3P4L	3P4L	
		CT 变比 CT ratio	—	1A 规格 spec: 1-5000 5A 规格 spec: 1-1000	1	
		保护选择 Protection selection	—	基波值、全波值 Fundamental wave value, full wave value	基波值 Fundamental wave value	
		通讯设置 Modbus RTU setting	地址 1 ADD 1	1-247	1	
			波特率 1 Baud rate1	1200、2400、4800、 9600、19200、38400	9600	bps
			校验位 1 Check digit 1	None/2stop/Odd/Even	None	
			地址 2 ADD 2	1-247	2	
			波特率 2 Baud rate2	2400、4800、9600、 19200、38400、 Profibus	9600	bps
			校验位 2 Check digit 2	None/2stop/Odd/Even	None	
		漏电保护 Electric leakage protection	—	开/关 Off/on	关 Off	
		变送设置 Transmitting set	类型 1 Type 1	Ia、Ib、Ic、Iav、 Uab、Ubc、Uca、 Uav、PTC、热容量 Heat capacity、P、F	Iav	
			满度值 1 Full value 1		2 倍额定电流 2 times rated current	
		语言选择 Language selection	—	中文、英语 Chinese、English	中文 Chinese	
		背光 backlight	—	1-30s, 0 为常亮 1-30s, 0 is normally on	0	
		液晶对比度 Liquid crystal contrast	—	0-100	50	%
		密码 password	—	0001-9999	0001	
		时间设置 Time setting	—	—	—	
		主界面索引 Main interface index	—	1-8	—	
		软件版本 Software version	—	—	—	
		恢复出厂 Factory reset	—	是、否 yes、no	—	
六	保护参数	定时限过载	报警阈值	100-800%	110%	%

VI	(低速) Protection parameters (low speed)	Fixed time overload	Alarm threshold			
			脱扣阈值 Trip threshold	100-800%	120%	%
			脱扣延时 Trip delay	0.1-600.0s	5.0s	s
			报警、脱扣允许 Alarm, trip allowed	报警：允许/禁止 Alarm:Allowed/ forbidden	允许 Allow	
		脱扣：允许/禁止 Trip:Allowed/ forbidden		允许 Allow		
		反时限过载 Inverse time overload	脱扣等级 Trip level	1、2、3、5、10、 15、20、25、30、 35、40	5	级 Class
			tE 脱扣等级 tE Trip level	2、3、4、5、6、8、 10、12、15	2	级 Class
			起动定值 Start setting	100~800%	120	%
			复位方式 Reset method	关/开 Off/on	关 Off	
			冷却时间 Cooling time	0-30min	1min	min
			报警阈值 Alarm threshold	1-99%	80%	%
			起动屏蔽时间 Starting screen time	0-25.0s	0.5s	s
			报警、脱扣允许 Alarm, trip allowed	报警：允许/禁止 Alarm:Allowed/ forbidden	允许 Allow	
		脱扣：允许/禁止 Trip:allowed/ forbidden		允许 Allow		
		欠载保护 Underload protection	报警阈值 Alarm threshold	10-99%	70%	%
			脱扣阈值 Trip threshold	10-99%	50%	%
			脱扣延时 Trip delay	0.1-600.0s	5.0s	s
			报警、脱扣允许 Alarm, trip allowed	报警：允许/禁止 Alarm:allowed/ forbidden	允许 Allow	
				脱扣：允许/禁止 Trip:allowed/ forbidden	禁止 Forbidden	
		断相保护 phase loss protection	脱扣延时 Trip delay	0.1-600.0s	1.0s	s
			报警、脱扣允许 Alarm, trip allowed	报警：允许/禁止 Alarm:allowed/ forbidden	允许 Allow	
				脱扣：允许/禁止 Trip:allowed/ forbidden	允许 Allow	

		电流不平衡 Current imbalance	报警阈值 Alarm threshold	10~80%	20	%
			脱扣阈值 Trip threshold	10~80%	30	%
			脱扣延时 Trip delay	0.1~600	5.0	S
			报警、脱扣允许 Alarm, trip allowed	报警：允许/禁止 Alarm:allowed/ forbidden	禁止 Forbidden	
				脱扣：允许/禁止 Trip:allowed/ forbidden	禁止 Forbidden	
			堵转保护 Locked rotor Protection	报警阈值 Alarm threshold	100-700%	500%
		脱扣阈值 Trip threshold		100-700%	600%	%
		脱扣延时 Trip delay		0.1-600.0s	5.0s	s
		报警、脱扣允许 Alarm, trip allowed		报警：允许/禁止 Alarm:allowed/ forbidden	允许 Allow	
				脱扣：允许/禁止 Trip:allowed/ forbidden	允许 Allow	
		接地/漏电保护 Ground fault protection		互感器投入 Transformer requirements	是/否 Yes/No	否 No
			接地报警阈值 Grounding alarm threshold	20-100%	20%	%
			接地脱扣阈值 Grounding trip threshold	20-100%	50%	%
			接地脱扣延时 Grounding trip delay	0.1-600.0s	0.1s	s
			接地跳闸方式 Trip mode	断路器/接触器 Circuit breaker / contactor	断路器 Circuit breaker	
			接地起动屏蔽 Grounding starting screen	0.0-25.0s	0.0s	s
			漏电报警阈值 Current leakage alarm threshold	100-1000mA	200mA	mA
			漏电脱扣阈值 Current leakage trip threshold	100-1000mA	300mA	mA
			漏电脱扣延时 Current leakage trip delay	0.1-600.0s	0.5s	s
			漏电跳闸方式 Trip mode of leakage mode	断路器/接触器 Circuit breaker / contactor	断路器 Circuit breaker	

			起动屏蔽时间 Starting screen time	0.0-600s	0.0	s
			报警、脱扣允许 Alarm, trip allowed	报警：允许/禁止 Alarm:allowed/ forbidden	允许 Allow	
		脱扣：允许/禁止 Trip:allowed/ forbidden		允许 Allow		
		短路保护 Short circuit protection	报警阈值 Alarm threshold	100-800%	起动报警 Start Alarm 400%	%
					运行报警 Run Alarm 400%	
			脱扣阈值 Trip threshold	100-800%	起动脱扣 Start Trip 500%	%
					运行脱扣 Run Trip 500%	
			脱扣延时 Trip delay	0.1-25.0s	0.1s	s
			报警、脱扣允许 Alarm, trip allowed	报警：允许/禁止 Alarm:allowed/ forbidden	允许 Allow	
		脱扣：允许/禁止 Trip:allowed/ forbidden		允许 Allow		
		溢出保护 Overflow protection	保护阈值 Protection threshold	100~800%	600	%
			报警、脱扣允许 Alarm, trip allowed	报警：允许/禁止 Alarm:allowed/ forbidden	允许 Allow	
				脱扣：允许/禁止 Trip:allowed/ forbidden	允许 Allow	
		阻塞保护 Blocking protection	报警阈值 Alarm threshold	100-700%	150%	%
			脱扣阈值 Trip threshold	100-700%	250%	%
			脱扣延时 Trip delay	0.1-600.0s	5.0s	s
			报警、脱扣允许 Alarm, trip allowed	报警：允许/禁止 Alarm:allowed/ forbidden	允许 Allow	
				脱扣：允许/禁止 Trip:allowed/ forbidden	允许 Allow	
		起动超时 Start timeout	动作阈值 action threshold	100%-200%	110%	%
			超时时间 Timeout time	0.1-600s	10.0s	s
报警、脱扣允许 Alarm, trip allowed	报警：允许/禁止 Alarm:allowed/ forbidden		允许 Allow			

				forbidden		
				脱扣: 允许/禁止 Trip:allowed/ forbidden	允许 Allow	
起 动 次 数 Start times	超 时 次 数 Timeout quantity	时 间 范 围 Time range	1-10	10	次 Time s	
			10-300min	30min	min	
	报 警 、 脱 扣 允 许 Alarm, trip allowed	报 警 : 允 许 /禁 止 Alarm:allowed/ forbidden	允 许 Allow			
		脱 扣 : 允 许 /禁 止 Trip:allowed/ forbidden	允 许 Allow			
过 电 压 overvoltage	报 警 阈 值 Alarm threshold	110-150%	110%	%		
	脱 扣 阈 值 Trip threshold	110-150%	120%	%		
	脱 扣 延 时 Trip delay	0.1-600.0s	5.0s	s		
	报 警 、 脱 扣 允 许 Alarm, trip allowed	报 警 : 允 许 /禁 止 Alarm:allowed/ forbidden	允 许 Allow			
		脱 扣 : 允 许 /禁 止 Trip:allowed/ forbidden	允 许 Allow			
欠 电 压 Under voltage	报 警 阈 值 Alarm threshold	50-90%	90%	%		
	脱 扣 阈 值 Trip threshold	50-90%	80%	%		
	脱 扣 延 时 Trip delay	0.1-600.0s	5.0s	s		
	报 警 、 脱 扣 允 许 Alarm, trip allowed	报 警 : 允 许 /禁 止 Alarm:allowed/ forbidden	禁 止 Forbidden			
		脱 扣 : 允 许 /禁 止 Trip:allowed/ forbidden	禁 止 Forbidden			
电 压 不 平 衡 Voltage unbalance	报 警 阈 值 Alarm threshold	10-99%	15%	%		
	脱 扣 阈 值 Trip threshold	10-99%	20%	%		
	脱 扣 延 时 Trip delay	0.1-600.0s	0.5s	s		
	报 警 、 脱 扣 允 许 Alarm, trip allowed	报 警 : 允 许 /禁 止 Alarm:allowed/ forbidden	禁 止 Forbidden			
		脱 扣 : 允 许 /禁 止 Trip:allowed/ forbidden	禁 止 Forbidden			
相 序 Phase sequence	脱 扣 延 时 Trip delay	0.1-25.0s	1.0s	s		

			报警、脱扣允许 Alarm, trip allowed	报警：允许/禁止 Alarm:allowed/forbid den	禁止 Forbidden	
				脱扣：允许/禁止 Trip:allowed/ forbidden	禁止 Forbidden	
过功率 Over power		报警阈值 Alarm threshold		100-700%	150%	%
		脱扣阈值 Trip threshold		100-700%	250%	%
		脱扣延时 Trip delay		0.1-600.0s	5.0s	s
		报警、脱扣允许 Alarm, trip allowed	报警：允许/禁止 Alarm:allowed/ forbidden	禁止 Forbidden		
			脱扣：允许/禁止 Trip:allowed/ forbidden	禁止 Forbidden		
欠功率 under-power		报警阈值 Alarm threshold		0-100%	80%	%
		脱扣阈值 Trip threshold		0-100%	50%	%
		脱扣延时 Trip delay		0.1-600.0s	5.0s	s
		报警、脱扣允许 Alarm, trip allowed	报警：允许/禁止 Alarm:allowed/ forbidden	禁止 Forbidden		
			脱扣：允许/禁止 Trip:allowed/ forbidden	禁止 Forbidden		
温度保护 temperature protection		NTC/PTC		NTC/PTC	PTC	
		报警阈值 Alarm threshold		100-30000 Ω	1600 Ω	Ω
		脱扣阈值 Trip threshold		100-30000 Ω	3600 Ω	Ω
		脱扣延时 Trip delay		0.1-600.0s	5.0s	s
		复位方式 Reset method		手动、自动 Manual and automatic	自动 automatic	
		返回阻值 Return resistance value		100-30000 Ω	1500 Ω	
		报警、脱扣允许 Alarm, trip allowed	报警：允许/禁止 Alarm:allowed/ forbidden	禁止 Forbidden		
			脱扣：允许/禁止 Trip:allowed/ forbidden	禁止 Forbidden		
		外部故障 external fault		脱扣延时 Trip delay		0.1-600.0s
报警、脱扣允许 Alarm, trip allowed				报警：允许/禁止 Alarm:allowed/ forbidden	禁止 Forbidden	

				脱扣：允许/禁止 Trip:allowed/ forbidden	禁止 Forbidden	
		运行超时 Run timeout	报警阈值 Alarm threshold		10000h	h
			报警允许 Alarm allowed	允许/禁止 allowed/forbidden	禁止 Forbidden	
		故障次数 Fault times	报警阈值 Alarm threshold		1000 次	次 Time s
			报警允许 Alarm allowed	允许/禁止 allowed/forbidden	禁止 Forbidden	
保护参数 (高速) Protecting parameters (high speed)	参考低速保护设定表 Refer to the low speed protection setting sheet					
七 VII	控制参数 Control parameters	控制权限 Control access	控制权限 Control access	显示单元、就地、 通讯、远程、三选 一、二选一、全控 Display unit, localization, communication, remote, 1 in 3,1 in 2, all control	全控 All contro	
		起动方式 Start method	起动模式 Start mode	保护模式、手动模 式、两步模式、双 速模式、星三角、 自耦降压 Protection mode, manual mode, two-step mode, two-speed mode, star triangle, auto-step-down	保护模式 Protected mode	
		自起动 Self start	自起动模式 Self start mode	恢复/起动 recover/start	起动 start	
			自起动延时 Self start delay	0.1~600	5.0	S
			自起动控制 Self start control	开/关 On/off	关 Off	
		失压重起动 Voltage loss restart	恢复电压 Recovery voltage	70-95%	80	%
			跌落电压 Voltage drop	50-90%	50	%
			晃电时间 Sway electric time	0.5-300.0	5.0	S
			重起延时 Restart delay	1.0-60.0s	30.0	S
			立即重启时间 Immediate restart	0.1-10.0s	0.5	S

			time			
			重启功能 Restart function	开/关 On/off	关 Off	
			DI1 类型 DI1 type	常开/常闭 Normally on/normally off	常开 Normally on	
八 VIII	可编程设置 Programmable set	DI 设置 DI set	DI1	普通 DI、起动 1(就地)、起动 1(远程)、 起动 2(就地)、起动 2(远程)、 停车(就地)、停车(远程)、 复位、紧急停车、外部故障、 单点起停 1(就地)、单点起停 1(远程)、单点起停 2(就地)、 单点起停 2(远程)、单点起停 1 使能、单点起停 2 使能、 控制权限 1、控制权限 2 Ordinary DI, start 1(in situ), start 1(remote), start 2(in situ), star 2(remote), stop (in situ), stop (remote), reset, emergency stop, external fault, single point start-stop 1 (local), single point start-stop 1 (remote), single point start-stop 2 (local), single point start-stop 2 (remote), single point start-stop 1 (enable),single point start-stop2 (enable), control over 1, control over 2	停车 Stop	
			DI2	同上 Ditto	起动 1 Start1	
			DI3	同上 Ditto	起动 2 Start2	
			DI4	同上 Ditto	紧急停车 Urgent Stop	
			DI5	同上 Ditto	复位 Reset	
			DI6	同上 Ditto	控制权限 1 control right 1	
			DI7	同上 Ditto	控制权限 2	

					control right 2	
			DI8	同上 Ditto	外部故障 External fault	
			DO1 类型 DO1 type	常开/常闭 Normally on/normally off	常开 Normally on	
		DO 设置 DO setting	DO1 定义 DO1 Definition	不投入、起动 1、 起动 2、起动 3、停 车、跳接触器、跳 断路器、报警故障 输出、脱扣故障输 出、停止状态输出、 起动状态输出、运 行状态输出、通讯 控制输出、装置自 检输出、装置电源 输出、晃电工艺连 锁输出、晃电复位 信号输出、保护模 式晃电输出 1、保 护模式晃电输出 2、逻辑图输出 1、 逻辑图输出 2、逻 辑图输出 3、22-30 对应 DI1-9 控制 DO 输出 0-No input, 1-star 1, 2-start 2,3-start3, 4-parking,5-starting jumped contactor,6-circuit breakers,7-fault Alarm output,8-tripping fault output,9-the output state stopped,10-the starting state output,11-the output operation state,12-the communication control output,13-the output device self-checking,14-th e device output power,15-nowhere electric process output chain,16-electric reset signal output,17-protected mode have	起动 1 Start1	

				nowhere electricity output 1,18-protected mode electricity output 2,19-logic diagram output 1,20-logic diagram output 2, 21-logic diagram output 3, 22-30 corresponding DI1-9 control the DO output				
			脉冲时间 Pulse time	0.3-25.0s	0.0s	s		
			DO2	同上 Ditto	起动 2 start2			
			DO3	同上 Ditto	报警 alarm			
			DO4	同上 Ditto	脱扣 Trip			
			DO5	同上 Ditto	脱扣 Trip			
		逻辑图设置 Logic diagram setting	输入 A inputA	输入 A 定义 Input A definition	D11			
				输入 A 逻辑 Input A logic			正逻辑/反逻辑 Positive logic/Reserve logic	正逻辑 Positive logic
				输入 A 延时 Input A delay			0.0-60.0s	0.0s
			输入 B inputB	输入 B 定义 Input B definition	同上 Ditto	关闭 Off		

				输入 B 逻辑 Input B logic	正逻辑/反逻辑 Positive logic/Reserve logic	正逻辑 Positive logic			
				输入 B 延时 Input B delay	0.0-60.0s	0.0s			
			输入 C inputC	输入 C 定义 Input C definition	同上 Ditto	关闭 Off			
				输入 C 逻辑 Input C logic	正逻辑/反逻辑 Positive logic/Reserve logic	正逻辑 Positive logic			
				输入 C 延时 Input C delay	0.0-60.0s	0.0s			
			输入 D InputD	输入 D 定义 Input D definition	同上 Ditto	关闭 Off			
				输入 D 逻辑 Input D logic	正逻辑/反逻辑 Positive logic/Reserve logic	正逻辑 Positive logic			
				输入 D 延时 Input D delay	0.0-60.0s	0.0s			
			输入 E inputE	输入 E 定义 Input E definition	同上 Ditto	关闭 Off			
				输入 E 逻辑 Input E logic	正逻辑/反逻辑 Positive logic/Reserve logic	正逻辑 Positive logic			
				输入 E 延时 Input E delay	0.0-60.0s	0.0s			
			逻辑图 1 Logic diagram1				关闭、A、A*B、 A+B、A*B*C、 (A+B)*C、 (A*B)+C、A+B+C、 A*B*C*D、 (A+B)*C*D、 (A*B+C)*D、 (A+B+C)*D、 A*B*C+D、 (A+B)*C+D、 A*B+C+D、 A+B+C+D、 A*B*C*D*E、 (A+B)*C*D*E、 (A*B+C)*D*E、 (A+B+C)*D*E、 (A*B*C+D)*E、 ((A+B)*C+D)*E、 (A*B+C+D)*E、 (A+B+C+D)*E、	A	

				A*B*C*D+E、 (A+B)*C*D+E、 (A*B+C)*D+E、 (A+B+C)*D+E、 A*B*C+D+E、 (A+B)*C+D+E、 A*B+C+D+E、 A+B+C+D+E		
			逻辑图 2 Logic diagram2	同上 Ditto	A	
			逻辑图 3 Logic diagram3	同上 Ditto	A	
		Test	DO1	关/开 Off/on	关 Off	
			DO2	关/开 Off/on	关 Off	
			DO3	关/开 Off/on	关 Off	
			DO4	关/开 Off/on	关 Off	
			DO5	关/开 Off/on	关 Off	
九 IX	事件记录 Event record	DI 变位记录 DI displace records				
		起动记录 Start recording				
		停车记录 Stop record				
		再起动力记录 Restart record				
十 X	清除记录 Clear record	清除记录密码 Clear record password		0000-9999	0001	

8、通讯设置与说明 Communication Settings and instructions

8.1 Modbus RTU 通信协议概述 Modbus RTU Communication Protocol Overview

电气接口：RS485 半双工

波特率：1200/2400/4800/9600/19200/38400

地址：由一个字节组成（8 位二进制），十进制为 0~255，系统中只使用 1~247，其它保留

错误检测：CRC

Electrical interface: RS485 half duplex

Baud: 1200/2400/4800/9600/19200/38400

Address: Consists of one byte (8-bit binary), 0 to 255 in decimal, only 1 to 247 in the system, the rest reserved

Error detection: CRC

数据格式 Data format:

地址码 Address code	功能码 Function code	数据区 Data area	CRC 校验 CRC check
---------------------	----------------------	------------------	---------------------

数据长度 Data length:

1 个字节	1 个字节	N 字节	2 个字节
-------	-------	------	-------

1 byte	1 byte	N bytes	2 bytes
--------	--------	---------	---------

每字节位: 1 位起始位、8 位数据位 (最小有效位先发送)、无奇偶校验、1 位停止位

ARD2M 支持的 MODBUS 功能码:

Each byte bit: 1 bit start, 8 bit data (least significant bit sent first), no parity, 1 bit stop

MODBUS function code supported by ARD2M:

01(0x01)功能码: 读线圈状态 (继电器输出 DO, 地址 0 对应 DO1)

02(0x02)功能码: 读开关量输入状态 (DI, 地址 0 对应 DI1)

03/04(0x03、0x04)功能码: 读保持寄存器

05(0x05)功能码: 写线圈状态 (控制继电器输出 DO, 地址 0 对应 DO1)

06(0x06)功能码: 写单个寄存器

16(0x10)功能码: 写多个寄存器

01 (0x01) Function code: Read coil state (relay output DO, address 0 corresponds to DO1)

02 (0x02) Function code: Read switch input state (DI, address 0 corresponds to DI1)

03/04 (0x03, 0x04) Function code: read hold register

05 (0x05) Function code: write coil state (control relay output DO, address 0 corresponds to DO1)

06 (0x06) Function code: Write a single register

16 (0x10) function code: Write multiple registers

注 Note: 运行控制位、输出控制位使用 16 功能码写入。

The operation control bit and output control bit are written in 16 function codes.

通讯应用 Communications applications

本节所举实例尽可能采用下表格式 (数据为 16 进制)

The examples in this section use the following tabular format (in hexadecimal data) whenever possible

Addr	Fun	Data start		Data		CRC16	
		reg Hi	reg Lo	reg Hi	reg Lo	Lo	Hi
01H	03H	00H	00H	00H	06H	C5H	C8H
地址 Add	功能码 Function code	数据起始地址 Data starting address		数据读取个数 Data read qty		循环冗余校验码 Cyclic redundancy check code	

读数据 Read the data

例 1: 使用 01 功能读寄存器: 读取 01 号 ARD2M 保护器的 DO1-DO5 继电器输出状态

Example 1: Read register using the 01 function: read the OUTPUT status of DO1-DO5 relay of the 01 ARD2M protector

查询数据帧 Check data frame	01 01 00 00 00 05 FC 09
返回数据帧 Return data frame	01 01 01 10 50 44

例 2: 使用 02 功能读寄存器: 读取 01 号 ARD2M 保护器的 DI1-DI5 开关量输入状态

Example 2: Register read using the 02 function: read the di1-DI5 switch input status of the 01 ARD2M protector

查询数据帧 Check data frame	01 02 00 00 00 05 B8 09
---------------------------	-------------------------

返回数据帧 Return data frame	01 02 01 10 A0 44
----------------------------	-------------------

例 3: 使用 03 或 04 功能读寄存器: 读取 01 号 ARD2M, 从地址 400 开始读 3 个数据

Example 3: Register read using the 03 or 04 function: read 01 ARD2M and read 3 data from address 400

查询数据帧 Check data frame	01 03 01 90 00 03 04 1A
返回数据帧 Return data frame	01 03 06 00 00 00 00 00 0E D1

写数据 Write the data

例 4: 使用 05 功能写寄存器

Example 4: Use the 05 function to write registers

闭合 01 号 ARD2M 的 DO1 继电器:

Close DO1 relay no. 01 ARD2M:

查询数据帧 Check data frame	01 05 00 00 FF 00 8C 3A
返回数据帧 Return data frame	01 05 00 00 FF 00 8C 3A

断开 01 号 ARD2M 的 DO1 继电器:

Disconnect DO1 relay of No. 01 ARD2M:

查询数据帧 Check data frame	01 05 00 00 00 00 CD CA
返回数据帧 Return data frame	01 05 00 00 00 00 CD CA

例 5: 使用 06 功能写寄存器: 将 01 号 ARD2M 的 DO2 输出。开关量输入/输出状态的指示寄存器地址为 022DH, 第 022DH -9 位对应 DI1-10, 第 10 位对应 DO6, 第 11-15 位对应 DO1-5。

Example 5: Write register using 06 function: output DO2 of 01 ARD3M. The indicating register address of switch input/output state is 022DH, bit 022DH-9 corresponds to Di1-10, bit 10 corresponds to DO6, and bit 11-15 corresponds to DO1-5.

查询数据帧 Check data frame	01 06 02 2D 10 00 15 BB
返回数据帧 Return data frame	01 06 02 2D 10 00 15 BB

例 6: 使用 16 功能写寄存器: 将 01 号 ARD2M 的 DO2 输出。开关量输入/输出状态的指示寄存器地址为 022DH, 第 022DH -9 位对应 DI1-10, 第 10 位对应 DO6, 第 11-15 位对应 DO1-5。

Example 6: Write register with 16 function: output DO2 of 01 ARD2M. The indicating register address of switch input/output state is 022DH, bit 022DH-9 corresponds to Di1-10, bit 10 corresponds to DO6, and bit 11-15 corresponds to DO1-5.

查询数据帧 Check data frame	01 10 02 2D 00 01 02 10 00 8E 2D
返回数据帧 Return data frame	01 10 02 2D 00 01 90 78

ARD2M 详细 MODBUS 通讯地址见表 13

The detailed MODBUS address of ARD2M is shown in table 13

表 13 Table 13

分类 Classification	地址 Add.	参数 Parameter	读写属性 Read write attribute	取值范围 Value range	类型 Type
实时参数 Measure parameters	400	A 相有效值电流百分比 A Phase effective value current percentage	R	0-1200%	word
	401	B 相有效值电流百分比 B Phase effective value current percentage	R		word
	402	C 相有效值电流百分比 C Phase effective value current percentage	R		word
	403	平均有效值电流百分比 Average effective value current percentage	R		word
	404	最大有效值电流百分比 Maximum RMS current Percentage	R		word
	405	A 相基波电流百分比 A Phase fundamental current percentage	R		word
	406	B 相基波电流百分比 B Phase fundamental current percentage	R		word
	407	C 相基波电流百分比 C Phase fundamental current percentage	R		word
	408	平均基波电流百分比 Average fundamental current percentage	R		word
	409	最大基波电流百分比 Maximum fundamental current percentage	R		word
	410	接地电流百分比 Ground current percent	R		word
	411	正序电流百分比 positive sequence current percentage	R		word
	412	负序电流百分比 Negative sequence current percentage	R	word	
	413	A 相基波电流 A Phase fundamental current	R	0-65535/电流比例因子为实际值 0-65535/Current scaling factor is the actual value	word
	414	B 相基波电流 B Phase fundamental current	R		word
	415	C 相基波电流 C Phase fundamental current	R		word
416	Uab 基波线电压 Uab Fundamental line voltage	R	0~1999.9V	word	

417	Ubc 基波线电压 Ubc Fundamental line voltage	R	0~1999.9V	word
418	Uca 基波线电压 Uca Fundamental line voltage	R	0~1999.9V	
419	漏电电流 leakage current	R	30-3000mA	
420	A 相有效值电流 A Phase effective current	R	0-65535/电流比例因子为实际值 0-65535/current scaling factor is the actual value	word
421	B 相有效值电流 B Phase effective current	R		word
422	C 相有效值电流 C Phase effective current	R		word
423	Uab 有效值线电压 Uab RMS line voltage	R	0~1999.9V	word
424	Ubc 有效值线电压 Ubc RMS line voltage	R	0~1999.9V	word
425	Uca 有效值线电压 Uca RMS line voltage	R	0~1999.9V	word
426	频率 frequency	R	15.00-75.00Hz	word
427	电流不平衡度 Degree of current imbalance	R	0-100%	
428	累计热容量百分比 Percentage of cumulative heat capacity	R	0-100%	word
429	温度阻值 Temperature resistance	R	0-65535Ω	word
430	零序电压百分比 Zero sequence voltage percent	R	0-999%	高字节 word High byte word
431	正序电压百分比 Percentage of positive sequence voltage	R	0-999%	低字节 word Low byte word
432	负序电压百分比 Percentage of Negative sequence voltage	R	0-999%	符号短整型 signed short int
433	电压不平衡 Voltage imbalance	R	0-999%	
434	AB 相电压相角差 AB Phase voltage phase Angle difference	R	0-359.9°	word
435	BC 相电压相角差 BC Phase voltage phase Angle difference	R	0-359.9°	
436	CA 相电压相角差	R	0-359.9°	

		CA Phase voltage phase Angle difference			
437-439		保留 Retain	R		
440	基波总有功功率 fundamental wave Total active power		R	32 位有符号数， 高字在前，低字在后 单位 W 32 bit signed number, High byte before, low byte after Unit:W	高字 word High byte word
441			R		低字 word Low byte word
442	基波总无功功率 fundamental wave Total reactive power		R	32 位有符号数， 高字在前，低字在后 单位 var 32 bit signed number, High byte before, low byte after Unit:var	高字 word High byte word
443			R		低字 word Low byte word
444	基波总视在功率 fundamental wave Total apparent power		R	32 位无符号数， 高字在前，低字在后 单位 VA 32 bit unsigned number, High byte before, low byte after Unit:VA	高字 word High byte word
445			R		低字 word Low byte word
446	基波总有功电能 Fundamental wave total active energy		R	32 位无符号数， 高字在前，低字在后 单位 Wh 32 bit unsigned number, High byte before, low byte after Unit: Wh	高字 word High byte word
447			R		低字 word Low byte word
448	基波总无功电能 Fundamental wave total reactive energy		R	32 位无符号数， 高字在前，低字在后 单位 varh 32 bit unsigned number, High byte before, low byte after Unit: varh	高字 word High byte word
449			R		低字 word Low byte word
450	基波 A 相有功 fundamental wave A phase active		R	32 位有符号数， 高字在前，低字在后 单位 W 32 bit signed number, High byte before, low byte after Unit:W	高字 word High byte word
451			R		低字 word Low byte word
452	基波 B 相有功 fundamental wave B phase active		R	32 位有符号数， 高字在前，低字在后 单位 W 32 bit signed number,	高字 word High byte word
453			R		低字 word Low byte word

				High byte before, low byte after Unit:W	
454	基波 C 相有功 fundamental wave C phase active	R	32 位有符号数, 高字在前, 低字在后 单位 W	32 bit signed number, High byte before, low byte after Unit:W	高字 word High byte word
455		R			低字 word Low byte word
456	基波 A 相无功 Fundamental wave A phase reactive	R	32 位有符号数, 高字在前, 低字在后 单位 var	32 bit signed number, High byte before, low byte after Unit:var	高字 word High byte word
457		R			低字 word Low byte word
458	基波 B 相无功 Fundamental wave B phase reactive	R	32 位有符号数, 高字在前, 低字在后 单位 var	32 bit signed number, High byte before, low byte after Unit:var	高字 word High byte word
459		R			低字 word Low byte word
460	基波 C 相无功 Fundamental wave C phase reactive	R	32 位有符号数, 高字在前, 低字在后 单位 var	32 bit signed number, High byte before, low byte after Unit:var	高字 word High byte word
461		R			低字 word Low byte word
462	基波 A 相视在 fundamental wave A phase apparent	R	32 位无符号数, 高字在前, 低字在后 单位 VA	32 bit unsigned number, High byte before, low byte after Unit:VA	高字 word High byte word
463		R			低字 word Low byte word
464	基波 B 相视在 fundamental wave B phase apparent	R	32 位无符号数, 高字在前, 低字在后 单位 VA	32 bit unsigned number, High byte before, low byte after Unit:VA	高字 word High byte word
465		R			低字 word Low byte word
466	基波 C 相视在 fundamental wave C phase apparent	R	32 位无符号数, 高字在前, 低字在后 单位 VA	32 bit unsigned number, High byte before, low byte after Unit:VA	高字 word High byte word
467		R			低字 word Low byte word
468-	保留 Retain	R			

	495				
	496	基波功率因数 Fundamental wave power factor		-1.000~1.000	word
	497	基波 A 相功率因数 Fundamental wave A phase power factor		-1.000~1.000	word
	498	基波 B 相功率因数 Fundamental wave B phase power factor		-1.000~1.000	word
	499	基波 C 相功率因数 Fundamental wave C phase power factor		-1.000~1.000	word
	500-503	保留 Retain	R		
	504	年月 Year,month	R/W	高 High byte:00-99,低 Low byte:0-12	word
	505	日时 Day,hour	R/W	高 High byte:0-31,低 Low byte:0-23	word
	506	分秒 Minute,second	R/W	高 High byte:0-59,低 Low byte:0-59	word
	507	基波有功电能进位 Carry of fundamental wave active electric energy	R	0-65535	word
	508	基波无功电能进位 Carry of fundamental wave reactive electric energy	R	0-65535	word
	509	总有功电能进位 Carry of total active electric energy	R	0-65535	word
	510	总无功电能进位 Carry of total active electric energy	R	0-65535	word
	511-549	保留 Retain	R		
电机运行信息 Motor running information	550	本次电机运行时间 Motor running time by now	R	0-65535 小时 Hour	word
	551	本次电机停车时间 Motor stopping time by now	R	0-65535 小时 Hour	word
	552	总运行时间 Motor running time	R	0-65535 小时 Hour	word
	553	总停车时间 Total stopping time	R	0-65535 小时 Hour	word
	554	总起动次数 Total running times	R	0-65535	word
	555	总脱扣次数 Total tripping times	R	0-65535	word
	556	DI 状态 DI style	R	Bit0-bit9 对应开关量输入 DI1-DI10 Bit0-bit8 To Switch Input DI1-DI9	word

	557	DO 状态 DO style	R/W	Bit0 继电器 1、Bit1 继电器 2、Bit2 继电器 3、Bit3 继电器 4、Bit4 继电器 5、Bit5 继电器 6 Bit0 relay 1, Bit1 relay 2, Bit2 relay 3, Bit3 relay 4, Bit4 relay 5, Bit5 relay 6	
	558	DI 类型 DI style	R	0- 直流类型; 1-交流类型 0-DC type; 1-AC type	
	559	电机状态 Motoe state	R	bit0 就绪; bit1 停车; bit2 启动; bit3 运行; bit4 报警; bit5 脱扣; bit7 0-低速 1-高速 bit0 readiness; bit1 Stopping; bit2 start; bit3 operation; bit4 alarm; bit5 tripping; bit7 0- Low speed 1- High speed	word
	560	脱扣故障指示 1 Trip Breakdown fault indication 1		Bit0 反时限过载脱扣; Bit1 接地/漏电脱扣; Bit2 欠载脱扣; Bit3 断相脱扣; Bit4 欠压脱扣; Bit5 过压脱扣; Bit6 堵转脱扣; Bit7 阻塞脱扣; Bit8 电流不平衡脱扣; Bit9 PTC 温度脱扣; Bit10 外部故障脱扣; Bit11 启动超时脱扣; Bit12 过功率脱扣; Bit13 欠功率脱扣; Bit14 相序脱扣; Bit15 短路脱扣。 (0-无脱扣, 1-有脱扣) Bit0 reverse time limit overload tripping; Bit1 grounding tripping; Bit2 underload tripping Bit3 disconnection; Bit4 undervoltage release; Bit5 overvoltage release; Bit6 blocking and tripping; Bit7 blocking tripping; Bit8 current imbalance tripping; Bit9 PTC temperature tripping; Bit10 external failure tripping; Bit11 start timeout release; Bit12 power tripping; Bit13 underpower tripping;	word

				Bit14 phase sequence tripping; Bit15 short circuit tripping. (0- No tripping, 1- tripping)	
561	脱扣故障指示 2 Trip Breakdown fault indication 2	R	Bit0 定时限过载脱扣; Bit1 电压不平衡脱扣; Bit2 溢出保护脱扣; Bit3 起动次数脱扣; Bit0 fixed time limit overload tripping; Bit1 voltage unbalanced tripping; Bit2 overflow protection tripping; Bit3 starting times tripping.	word	
562	报警故障指示 1 Alarm fault indication 1	R	Bit0 反时限过载报警; Bit1 接地/漏电报警; Bit2 欠载报警; Bit3 断相报警; Bit4 欠压报警; Bit5 过压报警; Bit6 堵转报警; Bit7 阻塞报警; Bit8 电流不平衡报警; Bit9 PTC 温度报警; Bit10 外部故障报警; Bit11 起动超时报警; Bit12 过功率报警; Bit13 欠功率报警; Bit14 相序报警; Bit15 短路报警。(0-无报警, 1-有报警) Bit0 anti-time overload alarm; Bit1 ground alarm; Bit2 underload alarm; Bit3 fault phase alarm; Bit4 undervoltage alarm; Bit5 overvoltage alarm; Bit6 blocking alarm; Bit7 blocking alarm; Bit8 current imbalance alarm; Bit9 PTC temperature alarm; Bit10 external fault alarm; Bit11 start timeout alarm; Bit12 power alarm; Bit13 underpower alarm; Bit14 phase sequence alarm; Bit15 short circuit alarm. (0- No alarm, 1- Alarm)	word	
563	报警故障指示 2 Alarm fault indication 2	R	Bit0 定时限过载报警; Bit1 电压不平衡报警; Bit2 溢出保护报警; Bit3 起动次数报警; Bit4 运行时间报警; Bit5 故障次数报警 Bit0 fixed time limit overload alarm;	word	

				Bit1 voltage imbalance alarm; Bit2 overflow protection alarm; Bit3 starting times alarm; Bit4 running time alarm; Bit5 fault times alarm	
564	过载剩余冷却时间 Overload remaining cooling time	R		0-30min	word
565	本次起动最大电流 Maximum starting current by now	R		0-65535	word
566	历史起动最大电流 Maximum Historical starting current	R		0-65535	word
567	本次运行最大电流 Maximum current in operation by now	R		0-65535	word
568	历史运行最大电流 Maximum Historical operation current	R		0-65535	word
569	最新故障记录通讯地址 Latest Fault Record Communication Address	R		2100、2150、2200、2250、2300、 2350、2400、2450	word
570	最新 DI 变位记录通讯地址 Latest DI Change Record Communication Address	R		1100、1108、1116、1124、1132、 1140、1148、1156	word
571	最新起动记录通讯地址 Latest Starting Record Communication Address	R		1300、1308、1316、1324、1332、 1340、1348、1356	word
572	最新停车记录通讯地址 Latest Stopping Record Communication Address	R		1500、1508、1516、1524、1532、 1540、1548、1556	word
573	最新再启动记录通讯地址 Latest Restart Record Communication Address	R		1700、1708、1716、1724、1732、 1740、1748、1756	word
574	最新参数设置通讯地址 Latest Parameter setting Communication Address	R		1900、1906、1912、1918、1924、 1930、1936、1942	word
575	最新装置上电记录通讯地址 Latest installation to record correspondence communication address	R		2020、2024、2028、2032、2036、 2040、2044、2048	word
576	最新装置断电记录通讯地址 Latest device power off record communication address	R		2052、2056、2060、2064、2068、 2072、2076、2080	word
577	当前记录到的上电次数	R		0-60000	word

		Current recorded times of power on			
	578	当前记录到的断电次数 Current recorded times of power off	R	0-60000	word
	579	下次起动能等待时间 Waiting time for next start	R	0-30min	word
	580	当前电机控制权限 Current Motor Control Authority	R	0- 面板; 1-就地; 2-通讯; 3-远程; 4-停车; 5-全控 0-panel;1-native;2-communication; 3-remote;4-stop ;5-All control	word
	581-596	保留 Retain	R		word
记录清除 Clear record	597	清除电能 Energy clear	W	写数据 0xa5b5 Write data 0xa5b5	word
	598	清除电机运行信息 Clear motor operation information	W	写数据 0xa5b5 Write data 0xa5b5	word
	599	清除事件记录 Event record clear	W	写数据 0xa5b5 Write data 0xa5b5	word
系统参数 System parameter	600	电流规格 Current	R	1.6、6.3、25.0、100.0、250.0、800.0、1.0、5.0	word
	601	电流比例因子 Current proportional factor	R	1、10、100	
	602	运行控制位 Operational control bits	R/W	1- 停车、2-起动能 1、3-起动能 2、4-紧急停车、5-复位 1-Stop、2-Start 1、3- Start 2、4-Emergency stop、5-reset	word
	603	恢复出厂设置 Restore factory setting	R/W	写数据 0xFFFF Write data 0xFFFF	word
	604	剩余电流互感器投入标志 Input Mark of Residual Current Transformer	R/W	0 没有投入, 1 投入 0 not input,1 input	word
	605	基波开关 Base Wave Switch	R/W	0 有效值, 1 基波 0 Rms,1 Fundamental wave	word
	606	电机类型 Motor type	R/W	0 普通电机, 1 增安电机 0 Common motor, 1 Increased safety motor	word
	607	CT 变比 CT Ratio	R/W	1A: 1-5000 5A: 1-1000 其他规格不可设 1A:1-5000 5A:1-1000 other specifications can not set CT ratio	word
	608	额定频率 Rated Frequency	R/W	45-70Hz 45-70Hz	word
	609	电机额定电流	R/W	1A:0.1-1.6A 5A:1.6-6.3A	word

		Motor rated current		25A:6.3-25.0A 100A:25.0-100.0A 250A:63.0-250.0A 800A:250.0-800.0A	
	610	电机额定电压 Motor rated voltage	R/W	57-1200	word
	611	电机额定功率	R/W	高位 High	word
	612	Motor rated Power	R/W	低位 Low	word
	613	接线方式 Wiring	R/W	0 单相模式, 1 三相四线, 2 三相 三线 0:1P,1:3P4L,2:3P3L	word
	614	背光常亮 Back light	R/W	1-30s, 0 为常亮 1-30s,0:Normally on	word
	615	对比度 Liquid crystal contrast	R/W	0~100	word
	616	主界面当前页面索引号 Main interface index	R/W	1-7 (0-20 可写) 1-7(0-20 can write)	word
	617	中英文切换 Language	R/W	0- 中文, 1-英文 0-Chinese,1-English	word
	618	电流屏蔽值 Current shield value	R/W	0-30	word
	619	密码 Password	R/W	0000-9999	
	620	变送模块 1 设定 Setting of transmission module 1	R/W	变送类型 Type; 0-Ia,1-Ib,2-Ic,3-Iav,4-Uab,5-Ubc, 6-Uca,7-Uav,8-PTC,9-热容量 Heat capacity,10-P,11-F	word
	621	变送模块 1 的满度对应值	R/W	电流默认 2 倍额定电流 2 times rated current	word
	622	Corresponding value of fullness of transmission module 1	R/W		
	623- 645	保留 Retain	R		word
	646	液晶版本 LCD Ver.	R		word
	647	液晶编号 LCD NO.	R		word
	648	主体版本 Main body Ver.	R		word
	649	主体编号 Main body NO.	R		word
低速保护 Low speed protection	650	脱扣允许位开/关 1 Trip allowed/forbidden 1	R/W	Bit0 反时限过载脱扣; Bit1 接地/ 漏电脱扣; Bit2 欠载脱扣; Bit3 断相脱扣; Bit4 欠压脱扣; Bit5 过压脱扣; Bit6 堵转脱扣; Bit7 阻塞脱扣; Bit8 电流不平衡脱扣; Bit9 PTC 温度脱扣; Bit10 外部故 障脱扣; Bit11 启动超时脱扣; Bit12 过功率脱扣; Bit13 欠功率脱 扣; Bit14 相序脱扣; Bit15 短路	word

				<p>脱扣。(0-不投入, 1-投入)</p> <p>Bit0 reverse time limit overload tripping;</p> <p>Bit1 grounding tripping;</p> <p>Bit2 underload tripping</p> <p>Bit3 disconnection;</p> <p>Bit4 undervoltage release;</p> <p>Bit5 overvoltage release;</p> <p>Bit6 blocking and tripping;</p> <p>Bit7 blocking tripping;</p> <p>Bit8 current imbalance tripping;</p> <p>Bit9 PTC temperature tripping;</p> <p>Bit10 external failure tripping;</p> <p>Bit11 start timeout release;</p> <p>Bit12 power tripping;</p> <p>Bit13 underpower tripping;</p> <p>Bit14 phase sequence tripping;</p> <p>Bit15 short circuit tripping.</p> <p>(0- No tripping, 1-trippng)</p>	
	651	<p>脱扣允许位开/关 2</p> <p>Trip allowed/forbidden 2</p>	R/W	<p>Bit0 定时限过载脱扣; Bit1 电压不平衡脱扣; Bit2 溢出保护脱扣;</p> <p>Bit3 起动次数脱扣;</p> <p>Bit0 fixed time limit overload tripping;</p> <p>Bit1 voltage unbalanced tripping;</p> <p>Bit2 overflow protection tripping;</p> <p>Bit3 starting times tripping.</p>	word
	652	<p>报警允许位开/关 1</p> <p>Alarm allowed/forbidden 1</p>	R/W	<p>Bit0 过载报警; Bit1 接地/接地报警; Bit2 欠载报警; Bit3 断相报警;</p> <p>Bit4 欠压报警; Bit5 过压报警;</p> <p>Bit6 堵转报警; Bit7 阻塞报警;</p> <p>Bit8 电流不平衡报警; Bit9 PTC 温度报警; Bit10 外部故障报警;</p> <p>Bit11 起动超时报警; Bit12 过功率报警; Bit13 欠功率报警; Bit14 相序报警; Bit15 短路。(0-不投入, 1-投入)</p> <p>Bit0 anti-time overload alarm;</p> <p>Bit1 ground alarm;</p> <p>Bit2 underload alarm;</p> <p>Bit3 fault phase alarm;</p> <p>Bit4 undervoltage alarm;</p> <p>Bit5 overvoltage alarm;</p> <p>Bit6 blocking alarm;</p>	word

				Bit7 blocking alarm; Bit8 current imbalance alarm; Bit9 PTC temperature alarm; Bit10 external fault alarm; Bit11 start timeout alarm; Bit12 power alarm; Bit13 underpower alarm; Bit14 phase sequence alarm; Bit15 short circuit alarm. (0- No alarm, 1- Alarm)	
653	报警允许位开/关 2 Alarm allowed/forbidden 2	R/W	Bit0 定时限过载报警; Bit1 电压不平衡报警; Bit2 溢出保护报警; Bit3 起动次数报警; Bit4 运行时间报警; Bit5 故障次数报警 Bit0 fixed time limit overload alarm; Bit1 voltage imbalance alarm; Bit2 overflow protection alarm; Bit3 starting times alarm; Bit4 running time alarm; Bit5 fault times alarm	word	
654	脱扣等级 Trip level	R/W	1、2、3、5、10、15、20、25、30、35、40	word	
655	tE 时间保护脱扣等级 tE Trip level	R/W	2、3、4、5、6、8、10、12、15	word	
656	过载起动定值 Overload starting fixed value	R/W	100-800%	word	
657	反时限过载复位方式 Inverse time limit overload reset method	R/W	0-关; 1-开 0-Off;1-On	word	
658	冷却时间 Cooling time	R/W	0-30min	word	
659	反时限过载报警阈值 Inverse time limit overload alarm threshold	R/W	1-99%	word	
660	反时限起动屏蔽时间 Inverse time limit starting shield time	R/W	0-25.0	word	
661	接地保护报警阈值 Ground protection alarm threshold	R/W	20%-100%		
662	接地保护脱扣阈值 Ground protection trip threshold	R/W	20%-100%		
663	接地脱扣延时	R/W	0.1~600.0s	word	

		Ground trip delay			
664		接地动作选择 Ground action selection	R/W	Bit0 动作选择 (0-跳断路器 1-跳接触器) Bit action selection (0- trip circuit breaker 1- trip contactor)	word
665		接地起动屏蔽时间 Ground starting shield time	R/W	0-25.0	word
666		漏电报警电流阈值 Leakage alarm threshold	R/W	(100~1000) mA	word
667		漏电脱扣电流阈值 Leakage trip threshold	R/W	(100~1000) mA	word
668		漏电脱扣延时 Leakage trip delay	R/W	0.1~600.0s	
669		漏电动作选择 Leakage action selection	R/W	Bit0 动作选择 (0-跳断路器 1-跳接触器) Bit action selection (0- trip circuit breaker 1- trip contactor)	
670		漏电起动屏蔽时间 Leakage starting shield time	R/W	0-25.0	
671		欠载报警阈值 Underload alarm threshold	R/W	10~99%	
672		欠载脱扣阈值 Underload trip threshold	R/W	10~99%	
673		欠载脱扣延时 Underload trip delay	R/W	0.1~600.0s	word
674		断相脱扣延时 Phase loss trip delay	R/W	0.1~600.0s	word
675		欠电压报警阈值 Under voltage alarm threshold	R/W	50~90%	
676		欠电压脱扣阈值 Under voltage trip threshold	R/W	50~90%	word
677		欠电压脱扣延时 Under voltage trip delay	R/W	0.1~600.0s	word
678		过电压报警阈值 Over voltage alarm threshold	R/W	110~150%	
679		过电压脱扣阈值 Over voltage alarm threshold	R/W	110~150%	
680		过电压脱扣延时 Over voltage trip delay	R/W	0.1~600.0s	word
681		堵转报警阈值 Locked-rotor alarm threshold	R/W	100~700%	
682		堵转脱扣阈值 Locked-rotor trip threshold	R/W	100~700%	

683	堵转脱扣延时 Locked-rotor trip delay	R/W	0.1~600.0s	word
684	阻塞报警阈值 Blocking alarm threshold	R/W	100~700%	
685	阻塞脱扣阈值 Blocking trip threshold	R/W	100~700%	
686	阻塞脱扣延时 Blocking trip delay	R/W	0.1~600.0s	word
687	电流不平衡报警阈值 Current unbalance alarm threshold	R/W	10~99%	
688	电流不平衡脱扣阈值 Current unbalance trip threshold	R/W	10~99%	
689	电流不平衡脱扣延时 Current unbalance trip delay	R/W	0.1~600.0s	word
690	NTC /PTC	R/W	0 NTC, 1PTC	
691	温度阻值报警值 Temperature alarm threshold	R/W	100~30000	
692	温度阻值脱扣值 Temperature trip threshold	R/W	100~30000	word
693	温度脱扣延时 Temperature trip delay	R/W	0.1~600.0s	
694	温度保护复位方式 Temperature protection reset mode	R/W	0- 手动; 1-自动 0-Manual;1-Automatic	
695	温度返回阻值 Temperature return resistance	R/W	0-关闭此功能。100~30000 表示返回值为 100~30000 间 可设定 0-Off.Can be set between 100-30000	
696	外部故障脱扣延时 External fault trip delay	R/W	0.1~600.0s	word
697	起动超时动作阈值 Start timeout trip threshold	R/W	100%~200%	word
698	起动超时时间 Start time	R/W	0.1~600.0s	
699	过功率报警阈值 Over power alarm threshold	R/W	100~700%	
700	过功率脱扣阈值 Over power trip threshold	R/W	100~700%	word
701	过功率脱扣延时 Over power trip delay	R/W	0.1~600.0s	
702	欠功率报警阈值	R/W	0~100%	

		Under power alarm threshold			
	703	欠功率脱扣阈值 Under power trip threshold	R/W	0~100%	word
	704	欠功率脱扣延时 Under power trip delay	R/W	0.1~600.0s	
	705	相序脱扣延时 Phase sequence trip delay	R/W	0.1~600.0s	
	706	短路起动阶段报警阈值 Short-circuit alarm threshold when starting	R/W	400%~800%	
	707	短路起动阶段脱扣阈值 Short-circuit trip threshold when starting	R/W	400%~800%	word
	708	短路运行阶段报警阈值 Short-circuit alarm threshold when running	R/W	400%~800%	
	709	短路运行阶段脱扣阈值 Short-circuit trip threshold when running	R/W	400%~800%	
	710	短路脱扣延时 Short-circuit trip delay	R/W	0.1~600.0s	word
	711	定时限过载报警阈值 Fixed time limit overload alarm threshold	R/W	100-800%	word
	712	定时限过载脱扣阈值 Fixed time limit overload trip threshold	R/W	100-800%	
	713	定时限过载脱扣延时 Fixed time limit overload trip delay	R/W	0.1~600.0s	word
	714	电压不平衡报警阈值 Voltage unbalance alarm threshold	R/W	10~99%	
	715	电压不平衡脱扣阈值 Voltage unbalance trip threshold	R/W	10~99%	
	716	电压不平衡脱扣延时 Voltage unbalance trip delay	R/W	0.1~600.0s	
	717	溢出保护阈值 Overflow protection threshold	R/W	400%~800%	
其他报警 Other alarm	718	起动次数报警条件 Start times alarm threshold	R/W	1-10 单位次数 unit:time	
	719	起动次数时间范围 Start times protection delay	R/W	10-300min	

	720	运行时间报警条件 Running time alarm threshold	R/W	1000-60000 单位小时 Unit:hour	
	721	故障次数报警条件 Times of alarm threshold	R/W	20-10000 单位次数 unit:time	
	722-799	保留 Retain	R		
高速 High speed protection	800	高速脱扣允许位 1 High speed trip allowed 1	R/W	高速保护参数相关,内容定义同低速时,默认值不同 Content is consistent with low speed,but the default value is different	
	801	高速脱扣允许位 2 High speed trip allowed 2	R/W		
	802	高速报警允许位 1 High speed alarm allowed 1	R/W		
	803	高速报警允许位 2 High speed alarm allowed 2	R/W		
	804	高速额定电流 High speed rated current	R/W		
	805	高速额定功率	R/W		
	806	High speed rated power	R/W		
	807	高速脱扣等级 High speed trip level	R/W		
	808	高速 TE 脱扣等级 High speed tE trip level	R/W		
	809	高速反时限过载起动定值 High speed Inverse time limit overload starting fixed value	R/W		
	810	高速反时限过载复位方式 High speed Inverse time limit overload rest method	R/W		
	811	高速反时限过载冷却时间 High speed Inverse time limit overload cooling time	R/W		
	812	高速反时限过载报警阈值 High speed Inverse time limit overload overload alarm threshold	R/W		
	813	高速起动屏蔽时间 High speed starting shield time	R/W		
	814	高速欠载报警阈值 High speed underload alarm threshold	R/W		
815	高速欠载脱扣阈值	R/W			

		High speed underload trip threshold			
816		高速欠载脱扣延时 High speed underload trip delay	R/W		
817		高速堵转报警阈值 High speed locked-rotor alarm threshold	R/W		
818		高速堵转脱扣阈值 High speed locked-rotor trip threshold	R/W		
819		高速堵转脱扣延时 High speed locked-rotor trip delay	R/W		
820		高速阻塞报警阈值 High speed blocking alarm threshold	R/W		
821		高速阻塞脱扣阈值 High speed blocking trip threshold	R/W		
822		高速阻塞脱扣延时 High speed blocking trip delay	R/W		
823		高速电流不平衡报警阈值 alarm threshold	R/W		
824		高速电流不平衡脱扣阈值 High speed current unbalance trip threshold	R/W		
825		高速电流不平衡脱扣延时 High speed current unbalance trip delay	R/W		
826		高速起动超时动作阈值 High speed starting timeout threshold	R/W		
827		高速起动超时时间 High speed starting timeout time	R/W		
828		高速过功率报警阈值 High speed over power alarm threshold	R/W		
829		高速过功率脱扣阈值 High speed over power trip threshold	R/W		
830		高速过功率脱扣延时 High speed over power trip delay	R/W		
831		高速欠功率报警阈值 High speed under power alarm threshold	R/W		

	832	高速欠功率脱扣阈值 High speed under power trip threshold	R/W		
	833	高速欠功率脱扣延时 High speed under power trip delay	R/W		
	834	高速短路起动阶段报警阈值 High speed short-circuit starting stage alarm threshold	R/W		
	835	高速短路起动阶段脱扣阈值 High speed short-circuit starting stage trip threshold	R/W		
	836	高速短路运行阶段报警阈值 High speed short-circuit running stage alarm threshold	R/W		
	837	高速短路运行阶段脱扣阈值 High speed short-circuit running stage trip threshold	R/W		
	838	高速短路脱扣延时 High speed short-circuit trip delay	R/W		
	839	高速定时限过载报警阈值 High speed fixed time limit overload alarm threshold	R/W		
	840	高速定时限过载脱扣阈值 High speed fixed time limit overload trip threshold	R/W		
	841	高速定时限过载脱扣延时 High speed fixed time limit overload trip delay	R/W		
	842	高速断相脱扣延时 High speed phase loss trip delay	R/W		
	843-899	保留 Retain	R		
起动控制 Start control	900	自起动模式 Self-start mode	R/W	0-起动, 1-恢复 0-start, 1-restore	word
	901	自起动延时 Self-start delay	R/W	0.1~60.0s	word
	902	自起动控制 Self-start control	R/W	0-关、1-开 0-Off、1-ON	word
	903	控制权限设置 Control access	R/W	0-面板; 1-就地; 2-通讯; 3-远程; 4-三选一; 5-二选一; 6-全控 0-Panel; 1-Native; 2-Comm; 3-Remote; 4-1 in 3; 5- 1 in 2; 6-all control	word

904	三选一控制权限编程输出 1 1 in 3 permission output1	R/W	0-通讯; 1-就地; 2-面板; 3-停车; 4-远程 默认 0 0- Comm; 1- Native; 2- Panel; 3-Stop; 4-Remote the default is 0	word
905	三选一控制权限编程输出 2 1 in 3 permission output2	R/W	0-通讯; 1-就地; 2-面板; 3-停车; 4-远程 默认 1 0- Comm; 1- Native; 2- Panel; 3-Stop; 4-Remote the default is 1	word
906	三选一控制权限编程输出 3 1 in 3 permission output3	R/W	0-通讯; 1-就地; 2-面板; 3-停车; 4-远程 默认 2 0- Comm; 1- Native; 2- Panel; 3-Stop; 4-Remote the default is 2	word
907	三选一控制权限编程输出 4 1 in 3 permission output4	R/W	0-通讯; 1-就地; 2-面板; 3-停车; 4-远程 默认 3 0- Comm; 1- Native; 2- Panel; 3-Stop; 4-Remote the default is 3	word
908	起动模式 Start method	R/W	0-保护模式, 1-手动模式, 2-两步 起动, 3-双速模式, 4-星三角三继 电器模式, 5-自耦降压三继电器 模式 0-Protection mode,1-manual mode,2-two-step mode, 3-two-speed mode, 4-star triangle, 5-auto-step-down	word
909	起动一延时设定 Start1delay	R/W	0.1~60.0s	word
910	恢复电压设定 Recovery voltage setting	R/W	70~95%	word
911	立即再起动允许时间 Immediate restart time	R/W	0.1~10.0s	word
912	再起启动延时设定 Restart delay	R/W	1.0~60.0s	word
913	抗晃电起动控制 Restart control	R/W	0 关, 1=再起启动执行起动 1, 2=再 起动执行起动 2 0=Off, 1=operates on start 1, 2= operates on start 2	word
914	最大晃电允许时间 Sway electric time	R/W	0.5~300.0s	word
915	跌落电压设定 Voltage drop		50-90% 不可以大于恢复电压 0-90% ≤Recovery voltage	
916- 949	保留 Retain	R		word

可编程设定 Programmable setting	950	继电器初始状态设定 DO initial state setting	R/W	0-常开, 1-常闭; bit0-bit4 对应 DO1-DO5 0-Normally on, 1- Normally off; bit0-bit4 correspond DO1-DO5	word
	951	DO1 可编程定义 DO1 Definition	R/W	0-不投入、1-起动 1、2-起动 2、3- 起动 3、4-停车、5-跳接触器、6- 跳断路器、7-报警故障输出、8-脱 扣故障输出、9-停止状态输出、10- 起动状态输出、11-运行状态输出、 12-通讯控制输出、13-装置自检输 出、14-装置电源输出、15-晃电工 艺连锁输出、16-晃电复位信号输 出、17-保护模式晃电输出 1、18- 保护模式晃电输出 2、19-逻辑图 输出 1、20-逻辑图输出 2、21-逻 辑图输出 3、22-30 对应 DI1-9 控 制 DO 输出 0-No input, 1-start 1, 2-start 2, 3-start 3, 4-parking, 5-starting jumped contactor, 6-circuit breakers, 7-fault Alarm output, 8-tripping fault output,9-the output state stopped, 10-the starting state output, 11-the output operation state, 12-the communication control output,13-the output device self-checking, 14-the device output power, 15-nowhere electric process output chain, 16-electric reset signal output, 17-protected mode have nowhere electricity output 1, 18-protected mode electricity output 2,19- logic diagram output 1 output logic diagram,20- logic diagram output 2, 21- logic diagram output 3, 22-30 corresponding DI1-19 control the DO output	word
	952	DO1 动作设定 (时间) DO1 action setting(time)	R/W	0-电平; (3-250)-脉冲宽度, 单位 0.1S 0-Level; (3-250)-pulse time, unit:0.1S	word
	953	DO1 脱扣故障设定 1 DO1 trip fault setting1	R/W	同地址 650 脱扣允许设置 As same as 650	word
	954	DO1 脱扣故障设定 2	R/W	同地址 651 脱扣允许设置	word

		DO1 trip fault setting2		As same as 651	
955		DO1 报警故障设定 1 DO1 alarm fault setting1	R/W	同地址 652 脱扣允许设置 As same as 652	word
956		DO1 报警故障设定 2 DO1 alarm fault setting2	R/W	同地址 653 脱扣允许设置 As same as 653	word
957		DO2 可编程定义 DO2 Programmable	R/W	同 DO1 (951-956) As same as DO1(951-956)	word
958		DO2 动作设定 (时间) DO2 action setting(time)	R/W		word
959		DO2 脱扣故障设定 1 DO2 trip fault setting1	R/W		word
960		DO2 脱扣故障设定 2 DO2 trip fault setting2	R/W		word
961		DO2 报警故障设定 1 DO2 alarm fault setting1	R/W		word
962		DO2 报警故障设定 2 DO2 alarm fault setting2	R/W		word
963		DO3 可编程定义 DO3 Programmable	R/W		同 DO1 (951-956) As same as DO1(951-956)
964		DO3 动作设定 (时间) DO3 action setting(time)	R/W	word	
965		DO3 脱扣故障具体设定 1 DO3 trip fault setting1	R/W	word	
966		DO3 脱扣故障具体设定 2 DO3 trip fault setting2	R/W	word	
967		DO3 报警故障具体设定 1 DO3 alarm fault setting1	R/W	word	
968		DO3 报警故障具体设定 2 DO3 alarm fault setting2	R/W	word	
969		DO4 可编程定义 DO4 Programmable	R/W	同 DO1 (951-956) As same as DO1(951-956)	
970		DO4 动作设定 (时间) DO4 action setting(time)	R/W		word
971		DO4 脱扣故障具体设定 1 DO4 trip fault setting1	R/W		word
972		DO4 脱扣故障具体设定 2 DO4 trip fault setting2	R/W		word
973		DO4 报警故障具体设定 1 DO4 alarm fault setting1	R/W		word
974		DO4 报警故障具体设定 2 DO4 alarm fault setting2	R/W		word
975		DO5 可编程定义 DO5 Programmable	R/W		同 DO1 (951-956) As same as DO1(951-956)

	976	DO5 动作设定 (时间) DO5 action setting(time)	R/W		word
	977	DO5 脱扣故障具体设定 1 DO5 trip fault setting1	R/W		word
	978	DO5 脱扣故障具体设定 2 DO5 trip fault setting2	R/W		word
	979	DO5 报警故障具体设定 1 DO5 alarm fault setting1	R/W		word
	980	DO5 报警故障具体设定 2 DO5alarm fault setting5	R/W		word
	981-986	保留 Retain	R		
	987	DI 常开常闭设置 DI normally on and normally off setting	R/W	Bit0-Bit8 对应 DI1-9, 0-常开; 1-常闭 Bit0-Bit8 correspond DI1-9, 0-Normally on; 1- Normally off	
	988	DI1 可编程定义 DI1 Programmable	R/W	1-普通 DI, 2-起动 1(就地), 3-起动 1(远程), 4-起动 2(就地), 5-起动 2(远程), 6-停车(就地), 7-停车(远程), 8-复位, 9-紧急停车, 10-外部故障, 11-单点起停 1(就地), 12-单点起停 1(远程),13-单点起停 2(就地),14-单点起停 2(远程), 15-单点起停 1 使能, 16-单点起停 2 使能, 17-控制权限 1, 18-控制权限 2 1-Ordinary DI, 2-starting 1(in situ), 3-starting 1(remote), 4-starting 2(in situ), 5-starting 2(remote), 6-parking (in situ), 7-parking (remote), 8-reset, 9-emergency stop, 10-external fault, 11-single point 1 (in situ) start-stop, 12-single point 1 (remote) start-stop, 13-single point 2 (in situ) start-stop, 14-single point 2 (remote) start-stop, 15-single point 1 start/stop, 16-single point 2 start/stop, 17-control over 1, 18-control over 2	word
	989	DI2 可编程定义 DI2 Programmable	R/W		word
	990	DI3 可编程定义 DI3 Programmable	R/W	同上 Ditto	word
	991	DI4 可编程定义	R/W		word

		DI4 Programmable			
992		DI5 可编程定义 DI5 Programmable	R/W		word
993		DI6 可编程定义 DI6 Programmable	R/W		word
994		DI7 可编程定义 DI7 Programmable	R/W		word
995		DI8 可编程定义 DI8 Programmable	R/W		word
996		DI9 可编程定义 DI9 Programmable	R/W		word
997-1002		保留 Retain	R		
1003		逻辑图输入定义 1 Logic diagram 1	R/W	0-关闭 0-off; 1-A;2-A*B;3-A+B;4-A*B*C;5-(A+B)*C;6-(A*B)+C;7-A+B+C;8-A*B*C*D;9-(A+B)*C*D;10-(A*B+C)*D;11-(A+B+C)*D;12-A*B*C+D;13-(A+B)*C+D;14-A*B+C+D;15-A+B+C+D;16-A*B*C*D+E;17-(A+B)*C*D+E;18-(A*B+C)*D+E;19-(A+B+C)*D+E;20-(A*B*C+D)*E;21-((A+B)*C+D)*E;22-(A*B+C+D)*E;23-(A+B+C+D)*E;24-A*B*C*D+E;25-(A+B)*C*D+E;26-(A*B+C)*D+E;27-(A+B+C)*D+E;28-A*B*C+D+E;29-(A+B)*C+D+E;30-A*B+C+D+E;31-A+B+C+D+E	word
1004		输入条件 AInput A	R/W	低字节: 0-关闭; 1-9 对应 DI1-9; 17-21 对应 DO1-DO5; 27-起动的 1; 28-起动的 2; 29-起动的 3; 30-停车; 31-紧急停车; 32-停止状态; 33-起动的状态; 34-运行状态; 35-报警状态; 36-脱扣状态; 49-80 对应脱扣; 81-112 对应报警 高字节: 0-正逻辑 1-反逻辑 Low-byte:0-Clouse;1-9 correspond to DI1-19;17-21 correspond to DO1 - DO6;27-Starting 1;28-Starting 2;29-Starting 3;30-Stop,31-Emergency shutdown;32-Stop state;33-Starting state;34-Running state;35-Alarm status;36-Trip status;49-80	word

				correspond to trip type;81-112 correspond to alarm types High byte:0- Logical,1-illogical	
	1005	输入条件 BInput B	R/W	同地址 1004 As same as add.1004	word
	1006	输入条件 CInput C	R/W		word
	1007	输入条件 DInput D	R/W		word
	1008	输入条件 EInput E	R/W		word
	1009	输入 A 延时时间 Input A relay	R/W	0.0-60.0s	word
	1010	输入 B 延时时间 Input B relay	R/W	0.0-60.0s	word
	1011	输入 C 延时时间 Input C relay	R/W	0.0-60.0s	word
	1012	输入 D 延时时间 Input D relay	R/W	0.0-60.0s	word
	1013	输入 E 延时时间 Input E relay	R/W	0.0-60.0s	word
	1014	逻辑图输入定义 2 Logic diagram2	R/W	同逻辑图输入定义 1 (地址 1003~1013) As same as logic diagram 1 (address:1003~1013)	word
	1015	输入条件 AInput A	R/W		word
	1016	输入条件 BInput B	R/W		word
	1017	输入条件 CInput C	R/W		word
	1018	输入条件 DInput D	R/W		word
	1019	输入条件 EInput E	R/W		word
	1020	输入 A 延时时间 Input A relay	R/W		word
	1021	输入 B 延时时间 Input B relay	R/W		word
	1022	输入 C 延时时间 Input C relay	R/W		word
	1023	输入 D 延时时间 Input D relay	R/W		word
	1024	输入 E 延时时间 Input E relay	R/W	word	
	1025	逻辑图输入定义 3 Logic diagram3	R/W	同逻辑图输入定义 1 (地址 1003~1013) As same as logic diagram 1 (address:1003~1013)	word
	1026	输入条件 AInput A	R/W		word
	1027	输入条件 BInput B	R/W		word
	1028	输入条件 CInput C	R/W		word
	1029	输入条件 DInput D	R/W		word
	1030	输入条件 EInput E	R/W		word
	1031	输入 A 延时时间 Input A relay	R/W		word
	1032	输入 B 延时时间 Input B relay	R/W		word
	1033	输入 C 延时时间 Input C relay	R/W		word
	1034	输入 D 延时时间 Input D relay	R/W		word
	1035	输入 E 延时时间 Input E relay	R/W	word	
	1036-1039	保留 Retain	R		word
通讯设定 Communication set	1040	第一路通讯奇偶校验位 ADD 1	R/W	1~247	word
	1041	第一路通讯波特率设定 Baud rate1	R/W	0-38400,1-19200,2-9600,3-4800,4-	word

				2400,5-1200	
	1042	第一路通讯地址设定 Check digit 1	R/W	0-无校验, 1-2 位停止位, 3-奇校验, 4-偶校验 0-No check, 1-2stop bit, 3-Odd, 4-Even	word
	1043	第二路通讯奇偶校验位 ADD 2		1~247	word
	1044	第二路通讯波特率设定、Baud rate2	R/W	0-38400,1-19200,2-9600,3-4800,4-2400,5-1200,6-Profibus	word
	1045	第二路通讯地址设定 Check digit 2	R/W	0-无校验, 1-2 位停止位, 3-奇校验, 4-偶校验 0-No check, 1-2stop bit, 3-Odd, 4-Even	word
	1047-1099	保留 Retain	R/W		
DI 变位记录 1 DI displacement record 1	1100	DI 编号 DI NO.	R	1-9 对应 DI1-9 1-9 correspond to DI1-9	
	1101	DI 状态 DI status	R	0-断开 1-闭合 0-open 1-closed	
	1102	动作 1 时间-年月 Action 1 time-year month	R	高字节年, 低字节月 High byte:year,low byte:month	
	1103	动作 1 时间-日时 Action 1 time-day hour	R	高字节日, 低字节时 High byte:day,low byte:hour	
	1104	动作 1 时间-分秒 Action 1 time-minute second	R	高字节分, 低字节秒 High byte:minute,low byte:second	
	1105-1107	保留 Retain	R		
DI 变位记录 2-8 DI displacement record 2-8	1108-1115	同上 Ditto	R	同上 Ditto	
	1116-1123		R		
	1124-1131		R		
	1132-1139		R		
	1140-1147		R		
	1148-1155		R		
	1156-1163		R		
	1164-1259	保留 Retain	R		
起动记录 1 Start record 1	1300	起动位置 Start position	R	0-外部起动 1-通讯 2-就地 3-面板 4-远程 5-自起动 6-重起动	

				0-External start 1-Comm 2-Native 3-Panel 4-Remote 5-Self-start 6-Restart	
	1301	起动最大电流 Maximum current when starting	R	单位 Unit 1%	
	1302	起动最低电压 Minimum voltage when starting	R	单位 Unit 1%	
	1303	起动是否成功 Result of starting	R	1-起动中停车 2-进入运行状态 3- 进入脱扣状态 1-stop when starting 2-go into running status 3-go into trip status	
	1304	动作 1 时间-年月 Action 1 time-year month	R	高字节年,低字节月 High byte:year,low byte:month	
	1305	动作 1 时间-日时 Action 1 time-day hour	R	高字节日,低字节时 High byte:day,low byte:hour	
	1306	动作 1 时间-分秒 Action 1 time-minute second	R	高字节分,低字节秒 High byte:minute,low byte:second	
	1307	起动阶段用时 Start time	R	单位 Unit 0.1S	
起动记录 2-8 Start record 2-8	1308- 1315	同上 Ditto	R	同上 Ditto	
	1316- 1323		R		
	1324- 1331		R		
	1332- 1339		R		
	1340- 1347		R		
	1348- 1355		R		
	1356- 1363		R		
	1364- 1499	保留 Retain	R		
停车记录 1 Stop record 1	1500	停车位置 Stop position	R	0-外部停车 1-通讯 2-就地 3-面 板 4-远程 5-紧急停车 6-脱扣 7- 晃电停车 0-External stop 1-Comm 2-Native 3-Panel 4-Remote 5-Emergency stop 6-Voltage loss stop	
	1501	动作 1 时间-年月 Action 1 time-year month	R	高字节年,低字节月 High byte:year,low byte:month	
	1502	动作 1 时间-日时 Action 1 time-day hour	R	高字节日,低字节时 High byte:day,low byte:hour	

	1503	动作 1 时间-分秒 Action 1 time-minute second	R	高字节分,低字节秒 High byte:minute,low byte:second	
	1504- 1507	保留 Retain	R		
停车记录 2-8 Stop record 2-8	1508- 1515	同上 Ditto	R	同上 Ditto	
	1516- 1523		R		
	1524- 1531		R		
	1532- 1539		R		
	1540- 1547		R		
	1548- 1555		R		
	1556- 1563		R		
	1564- 1699	保留 Retain	R		
再起动记录 1 Restart record 1	1700	晃电原因 Cause of voltage shock	R	0-三相均失电 1-A 相 2-B 相 3-C 相 0-All three phase lost power 1-A phase 2-B phase 3-C phase	
	1701	最小电压 Minimum voltage	R	单位 Unit 1%	
	1702	晃电时间 Time of voltage shock		单位 Unit 1 0.1S	
	1703	晃电后动作 Action after voltage shock		1-保持 2-再启动 1 3-再启动 2 1-keep 2-restart 1 3-restart 2	
	1704	动作 1 时间-年月 Action 1 time-year month	R	高字节年,低字节月 High byte:year,low byte:month	
	1705	动作 1 时间-日时 Action 1 time-day hour	R	高字节日,低字节时 High byte:day,low byte:hour	
	1706	动作 1 时间-分秒 Action 1 time-minute second	R	高字节分,低字节秒 High byte:minute,low byte:second	
	1707	保留 Retain	R		
再起动记录 2-8 Restart record2-8	1708- 1715	同上 Ditto	R	同上 Ditto	
	1716- 1723		R		
	1724- 1731		R		
	1732-		R		

	1739				
	1740-1747		R		
	1748-1755		R		
	1756-1763		R		
	1804-1899	保留 Retain	R		
参数修改记录 1 Parameter change record 1	1900	修改时间-年月 Change time-year month	R		
	1901	修改时间-日时 Change time-day hour	R		
	1902	修改时间-分秒 Change time-minute second	R		
	1903	首通讯地址 First data	R		
	1904	通讯地址长度 Length of comm data	R		
	1905	设置方式 Set position	R	0=lcd,1=rs485-1,2=rs485-2,	
参数修改记录 2-8 Parameter change record 2-8	1906-1911	同上 Ditto	R	同上 Ditto	
	1912-1917		R		
	1918-1923		R		
	1924-1929		R		
	1930-1935		R		
	1936-1941		R		
	1942-1947		R		
	1948-2019	保留 Retain	R		
上电记录 1 Power on record1	2020	本条上电索引 Power on index	R	记录这一次是第几次上电 Record the number of this time power on	
	2021	装置上电时间-年月 Power on time-year month	R		
	2022	装置上电时间-日时 Power on time-day hour	R		
	2023	装置上电时间-分秒	R		

		Power on time-minute second			
上电记录 2-8 Power on record2-8	2024- 2027	同上 Ditto		同上 Ditto	
	2028- 2031				
	2032- 2035				
	2036- 2039				
	2040- 2043				
	2044- 2047				
	2048- 2051				
断电记录 1 Power off 1	2052	本条断电索引 Power off index	R	记录这一次是第几次断电 Record the number of this time power off	
	2053	装置断电时间-年月 Power off time-year month	R		
	2054	装置断电时间-日时 Power off time-day hour	R		
	2055	装置断电时间-分秒 Power off time-minute second	R		
断电记录 2-8 Power off 2-8	2056- 2059	同上 Ditto		同上 Ditto	
	2060- 2063				
	2064- 2067				
	2068- 2071				
	2072- 2075				
	2076- 2079				
	2080- 2083				
	2084- 2089	保留 Retain	R		
	2090- 2095	内部保留 Internal retain	R		
故障记录 1	2100	故障脱扣状态 1	R		

Fault record 1		Fault trip status 1			
	2101	故障脱扣状态 2 Fault trip status 2	R		
	2102	故障报警状态 1 Fault alarm status 1	R		
	2103	故障报警状态 2 Fault alarm status 2	R		
	2104	动作 1 时间-年月 Action 1 time-year month	R		
	2105	动作 1 时间-日时 Action 1 time-day hour	R		
	2106	动作 1 时间-分秒 Action 1 time-minute second	R		
	2107	基波开关、传感器类型 Fundamental wave switch, sensor type	R	bit0:基波开关; bit1:PTC/NTC 类型 bit0: fundamental wave switch; bit1:PTC/NTC type	
	2108	A 相电流 A phase current	R		
	2109	B 相电流 B phase current	R		
	4010	C 相电流 C phase current	R		
	2111	A 相电压 A phase voltage	R		
	2112	B 相电压 B phase voltage	R		
	2113	C 相电压 C phase voltage	R		
	2114	总视在功率 Total apparent power	R		
	2115		R		
	2116	总有功功率 Total active power	R		
	2117		R		
	2118	总无功功率 Total reactive power	R		
	2119		R		
	2120	总功率因数 Total power factor	R		
	2121	频率 Frequency	R		
	2122	零序电流 Zero sequence current	R		
	2123	零序电压 Zero sequence voltage	R		
	2124	PTC/NTC 阻值 PTC/NTC resistance	R		
	2125	漏电流 Leakage current	R		
	2126	DI 状态 DI status	R		
	2127	DO 状态 DO status	R		
	2128	电机状态 Motor statu	R	Bit1 停车; Bit2 起动; Bit3 运行; Bit4 报警 Bit1 stop; Bit2 start; Bit3 run; Bit4 alarm	
	2129-	保留	R		

	2149	Retain			
故障记录 2-8 Fault record 2-8	2150-2199	同上 Ditto	R	同上 Ditto	
	2200-2249		R		
	2250-2299		R		
	2300-2349		R		
	2350-2399		R		
	2400-2449		R		
	2450-2499		R		
	2500-4999	保留 Retain	R		
自定义通讯地址 Customize mailing address	5000	自定义地址 1 对应值 Correspond value of custom address 1	R	同对应的通讯地址 As same as the corresponding mailing address	
	5001	自定义地址 2 对应值 Correspond value of custom address 2	R		
	~	~	R		
	5119	自定义地址 120 对应值 Correspond value of custom address 120	R		
	5120-5299	保留 Retain	R		
	5300	自定义地址 1 对应的地址设置 Correspond address of custom address 1	R/W		
	~	~	R/W		
	5419	自定义地址 120 对应的地址设置 Correspond address of custom address 120	R/W		

9、特色功能简介 Features and Functions

9.1 权限可编程 Permissions programmable

保护器具有完善的控制权限可编程功能，配合权限为“二选一”或“三选一”时使用。

Protector has perfect control authority programmable function, with permission for "1 in 2" or "1 in 3" use.

当控制权限为“二选一”时，用户可将控制权限输出 1 与输出 2 定义：显示单元、通讯就地、远程和停车中的任一种（两者定义不可重复）。

When the control permission is "1 in 2 ", the user can define the control permission output 1 and output 2: either of

the panel, communication, remote and native (both definitions are not repeatable).

例如：控制权限定义为“二选一”，控制权限输出类型输出 1 定义为“通讯控制”，输出 2 定义为“就地控制”。DI6 定义为（控制权限 1），DI6（控制权限 1）断开时，控制权限输出 1 对应的控制方式生效；DI6（控制权限 1）接通时，输出 2 对应的控制方式生效。则控制权限选择如下表 14 所示：

For example, control permissions are defined as "1 in 2 ", control permission output type output 1 is defined as "communication control ", output 2 is defined as "panel control ". The DI6 is defined as (control permission 1). When DI6(control permission 1) is disconnected, the control mode corresponding to the control permission output 1 takes effect, and the control mode corresponding to the output 2 takes effect when the DI6(control permission 1) is connected. The control permissions are selected as shown in Table 14 below:

表 14 Table 14

控制权限输出类型 Control Permission Type	DI6 控制权限 1 输入状态 DI6 Control Permission Input 1 State
输出 1-通讯控制 Output 1-Communication control	0
输出 2-就地控制 Output 2-Panel control	1

当控制权限设置为“三选一”时，用户可将控制权限输出 1、输出 2、输出 3 和输出 4 分别定义为显示单元、通讯就地、远程和停车中的任一种（各输出定义不可重复），并通过 DI6（控制权限 1）、DI7（控制权限 2）的通断来选择生效的输出。若控制权限输出 1 定义为“通讯”控制，输出 2 定义为“就地”控制，输出 3 定义为“显示单元”控制，输出 4 定义为“远程”控制，则控制权限选择如下表 15 所示：

When the control permissions are set to "1 in 3", The user can define control rights output 1, output 2, output 3, and output 4 as either of the panel, communication, remote, and native, stop (each output definition is not repeatable), The effective output is selected by DI6(control permission 1), DI7(control permission 2) on-off. If control permission output 1 is defined as communication control, Output 2 is defined as panel control, Output 3 is defined as native control, Output 4 is defined as remote control, The control permissions are selected as shown in Table 15 below:

表 15 Table 15

控制权限 Control permissions	DI 输入状态 DI Input state	
	DI6 控制权限 1 DI6 Control permission 1	DI7 控制权限 2 DI7 Control permission 2
通讯控制 Communication control	0	0
就地控制 Panel control	0	1
显示单元控制 Native control	1	0
远程控制 Remote control	1	1

注：“0”表示开关量输入断开，“1”表示接通。

Note:"0" means switch input disconnected,"1" means turn on.

9.2 逻辑可编程 Logic programmable

保护器具有完善的逻辑可编程功能，用户可根据所需的逻辑输出功能进行编程定义。每路逻辑功能，由 5 项可编程的输入条件 A、B、C、D、E，通过“与”、“或”关系自由组合而成，每项输入条件的可编程内容以及输入条件的组合方式可参见表 12 菜单。

The protector has perfect logic programmable function, and the user can program and define according to the required logic output function. Each logic function consists of five programmable input conditions A、B、C、D、E, freely combined by "with "," or" relations. The programmable content of each input condition and the combination of input conditions can be seen in Table 12 menu.

例：假设用户需要在阻塞、短路、定时限过载、断相、电流不平衡中任一故障发生时输出无源信号，可将

DO3（也可用其它 DO）设置为逻辑图输出 1，将逻辑输出 1 的条件设置为 $A*B*C*D*E$ ，同时将条件输入 A、B、C、D、E 分别设置为阻塞、短路、定时限过载、断相、电流不平衡故障，则阻塞、短路、定时限过载、断相、电流不平衡故障任一故障发生时，DO3——逻辑图输出 1 动作，输出无源信号。

Suppose the user needs to output passive signal when any fault occurs in blocking, short circuit, time limit overload, phase break, current imbalance, can set DO3(or other DO) to logic diagram output 1, set the condition of logic output 1 to $A*B*C*D*E$, and set the condition input A、B、C、D、E to block, short circuit, time limit overload, phase break, current imbalance fault, then block, short circuit, time limit overload, phase break, current imbalance fault any fault occurs, DO3—— logic diagram output 1 action, output passive signal.

注：“+”表示与逻辑，“*”表示或逻辑。

Note：“+” representation and logic，“*” representation or logic.

9.3 自定义通讯地址 Custom communication address

保护器具有通讯地址自定义功能，使通讯读取更加便捷、有效。

The protector has the function of customizing communication address, which makes communication reading more convenient and effective.

有 120 个通讯地址可供用户自定义使用。地址 5000-5119 和 5300-5419，对应的数据值可自定义使用。如将 5300 的值写为 2010，则表示地址 5000 与地址 2010 数据相同相同。

There are 120 communication addresses for user customization. Address 5000-5119 and 5300-5419, the corresponding data values can be customized. If the value of 5300 is written as 2010, the address 5000 is the same as the address 2010 data.

例：假设用户需要频繁读写原地址 2003、2300、2307、2309、2335、2357、2758、2800。这几个地址不是连续地址，每读一个地址数据，需要发送一次 MODBUS 读命令。

Example: Suppose the user needs to read and write the original address 2003,2300,2307,2309,2335,2357,2758,2800 frequently. These addresses are not continuous addresses, each read an address data, need to send a MODBUS read command.

这种情况下可通过自定义通讯地址功能提高效率：用户可以将地址 5300-5307 分别写为 2003、2300、2307、2309、2335、2357、2758、2800，这样地址 5000-5007 的定义、读写属性、取值范围等将与上述地址一一对应。此时用户只需发送一次读命令，实现全部数据读写。

In this case, the efficiency can be improved by customizing the address function: the user can write the address 5300-5307 as 2003,2300,2307,2309,2335,2357,2758,2800 respectively, so that the definition of the address 5000-5007, read and write, value range and so on will correspond to the above address one by one. At this time, the user only needs to send a read command to achieve all data read and write.

10、订货范例 Examples of ordering

例 1：具体型号：ARD2M-100/CP

技术要求：电动机功率 37KW

通讯协议：MODBUS RTU 协议；PROFIBUS 协议

辅助电源：AC 220V

Example1: specific model: ARD2M-100/CP

Technical requirements: motor power37KW

Communication protocol:MODBUS RTU protocol; PROFIBUS protocol

Auxiliary power:AC 220V

例 2：具体型号：ARD2M-100/CC

技术要求：电动机功率 37KW

通讯协议：2 路 MODBUS RTU 协议

辅助电源: AC 220V

Example2: specific model: ARD2M-100/CC

Technical requirements: motor power37KW

Communication protocol:2 channels MODBUS RTU protocol

Auxiliary power:AC 220V

总部：安科瑞电气股份有限公司

Headquarter: Acrel Co., LTD.

地址：上海市嘉定区育绿路 253 号

Address: No.253 Yulv Road Jiading District, Shanghai, China

电话：0086-21-69158338 0086-21-69156052 0086-21-59156392 0086-21-69156971

TEL.: 0086-21-69158338 0086-21-69156052 0086-21-59156392 0086-21-69156971

传真：0086-21-69158303

Fax: 0086-21-69158303

网址：www.acrel-electric.com

Web-site: www.acrel-electric.com

邮箱：ACREL008@vip.163.com

Email: ACREL008@vip.163.com

邮编：201801

Postcode: 201801

生产基地：江苏安科瑞电器制造有限公司

Manufacturer: Jiangsu Acrel Electrical Manufacturing Co., LTD.

地址：江苏省江阴市南闸街道东盟工业园区东盟路 5 号

Address: No.5 Dongmeng Road, Dongmeng industrial Park, Nanzha Street, Jiangyin City, Jiangsu Province, China

电话：0086-510-86179966

TEL: 0086-510-86179966

传真：0086-510-86179975

Fax: 0086-510-86179975

网址：www.jsacrel.com

Web-site: www.jsacrel.com

邮箱：sales@email.acrel.cn

Email: sales@email.acrel.cn

邮编：214405

Postcode: 214405