

712



APView400
电能质量在线监测装置
Power Quality Monitor

安装使用说明书 V1.0

User's Manual V1.0

安科瑞电气股份有限公司
Acrel CO., LTD

申 明

DECLARATION

版权所有，未经本公司之书面许可，此手册中任何段落，章节内容均不得被摘抄、拷贝或以任何形式复制、传播，否则一切后果由违者自负。

本公司保留一切法律权利。

All rights reserved. No part of this publication may be reproduced, stored in a retrieval system, or transmitted in any form by any means, electronic, mechanical photocopying, recording, or otherwise without prior permission of our company. The violator will bear the dependent legal responsibility.

We reserve all the rights.

本公司保留对本手册所描述之产品规格进行修改的权利，恕不另行通知。

订货前，请垂询当地代理商以获悉本产品的最新规格。

We reserve all the rights to revise product specification without notice. Please consult local agent to get the latest information of our products specification.

目录 Contents

1 装置介绍	1
1 Introduction	1
1.1 概述	1
1.1 Overview	1
1.2 特点	1
1.2 Features	1
1.3 功能对照表	3
1.3 Functions	3
1.4 装置型号命名及选型	6
1.4 Type	6
1.5 功能简介	6
1.5 Overview	6
2 技术参数	13
2 Technical parameter	13
2.1 工作电源	13
2.1 Power supply	13
2.2 交流电流输入	13
2.2 AC current	13
2.3 交流电压输入	13
2.3 AC voltage	13
2.4 开关量输入	14
2.4 Digital input	14
2.5 开关量输出	14
2.5 Digital output	14
2.6 通讯接口	14
2.6 Communication port	14
2.7 监测精度对照表	15
2.7 Monitor accuracy	15
2.8 依据标准	18
2.8 Reference standard	18
2.9 工作环境	19
2.9 Working conditions	19
2.10 安全性能	20
2.10 Safety features	20
2.11 电磁兼容性能与机械性能	21
2.11 EMC and mechanical properties	21
3 机械结构与电气安装	23
3 Mechanical structure and installation	23
3.1 开孔尺寸与安装方式	23
3.1 Hole size and installation method	23

3.2 背部端子图	24
3.2 Back terminals	24
3.3 接线方式	26
3.3 Wiring	26
3.4 接地	27
3.4 Ground	27
3.5 电源	27
3.5 Power supply	27
3.6 模拟量输入回路	28
3.6 Analog input	28
3.7 通讯端口的连接	28
3.7 Communication port	28
4 人机界面	29
4 Human Machine Interface (HMI)	29
4.1 按键	30
4.1 Buttons	30
4.2 面板指示灯	30
4.2 LED lamps	30
4.3 快速导航	31
4.3 Quick navigation	31
4.4 操作说明	32
4.4 Operation instructions	32
5 定值清单	76
5 List of parameter	76
6 技术说明	80
6 Technical instructions	80
6.1 电压偏差	80
6.1 Voltage deviation	80
6.2 频率偏差	81
6.2 Frequency deviation	81
6.3 谐波	82
6.3 Harmonics	82
6.4 间谐波	85
6.4 Interharmonics	85
6.5 不平衡度	86
6.5 Unbalance	86
6.6 电压波动与闪变	87
6.6 Voltage fluctuation and flicker	87
6.7 电压暂升、暂降、中断	91
6.7 Voltage swell, dip and interruption	91
6.8 电流、电压瞬态	93
6.8 Transient current and voltage	93

1 装置介绍

1 Introduction

1.1 概述

1.1 Overview

APView400 电能质量在线监测装置采用了高性能多核平台和嵌入式操作系统，遵照 IEC61000-4-30 《测试和测量技术-电能质量测量方法》中规定的各电能质量指标的测量方法进行测量，集谐波分析、波形采样、电压暂降/暂升/中断、闪变监测、电压不平衡度监测、事件记录、测量控制等功能为一体。装置在电能质量指标参数测量方法的标准化和指标参数的测量精度以及时钟同步、事件告警功能等各个方面均达到了国家标准 A 级要求，能够满足 35kV 及以下供电系统电能质量监测的要求，广泛适用于化工、钢铁、冶金、医院、数据中心、交通建筑等行业的电能质量监测。

Power quality monitor APView500 integrates a high-performance multi-core platform and an embedded operating system, and monitors power quality indexes stipulated in IEC61000-4-30 *Testing and measurement techniques –Power quality measurement methods*, and provides various functions such as harmonic analysis, waveform sampling, voltage dips/swells/interruptions monitoring, flicker monitoring, voltage unbalance monitoring, event recording and measurement control. It meets IEC 61000-4-30 Class A Edition 3.1 with respect to standardization of power quality index measurement methods, measurement accuracy of index parameters, clock synchronization, event alarms and others and satisfy the demands of power quality monitoring of power supply system below 35kV. Therefore, it is widely applicable for power quality monitoring in chemical industry, steel industry, metallurgy industry, hospitals, data centers, transportation, construction industry and other industries.

1.2 特点

1.2 Features

1.2.1 高性能的硬件平台

1.2.1 High-performance hardware platform

装置采用基于 Xilinx SoC 构架的双 ARM 内核处理器, ARM1 运行嵌入式 Linux、TCP/IP 协议、Http 协议、Web 服务器、电能质量数据的存储、统计、分析, ARM2 用来数据采样、电能质量数据计算。装置每周波采样高达 1024 点, 具备高测量精度能准确记录故障波形。采用 32GB 工业级大容量 SD 卡, 可以长期存储事件记录与故障波形等数据。具备友好的人

机界面，800*480 像素点阵彩色大尺寸液晶可就地查看实时波形与故障波形，方便用户故障分析。

This product consists of a dual ARM-core processor based on Xilinx SoC architecture, in which ARM1 runs embedded Linux, TCP/IP protocol, Http protocol, Web server, and storage, statistics and analysis of power quality data, and ARM2 is used for data sampling and power quality data calculation. The sampling rate is 1024 points per cycle so that it measures data more accurately and record the fault waves correctly. Using a 32GB industrial-grade large-capacity SD card, it can store data such as event records and fault waveforms for a long time. With friendly HMI, an 800 * 480 pixels dot matrix large-size color LCD, users can monitor real-time waves and fault waves, and analyze faults easily.

1.2.2 丰富的接口资源

1.2.2 Various interfaces available

4 路交流电压；

4 channels of AC voltage；

4 路交流电流；

4 channels of AC current；

5 路可编程无源继电器出口、5 路有源开关量输入；

5 DO, 5 DI ；

2 路 RS485 串行通讯接口，支持 Modbus-RTU 规约，支持 IRIG-B 对时方式；

2 RS485, support the Modbus-RTU protocol and IRIG-B；

2 路以太网接口，支持 Modbus-TCP、IEC61850 MMS、FTP、装置升级维护；

2 Ethernet port, support Modbus-TCP、IEC61850 MMS、FTP and device update；

1 路 USB 接口，可用于装置维护。

1 USB,used for device updates.

1.2.3 可靠性设计

1.2.3 Reliability

装置软硬件具有持续完善的自检功能，抗干扰性能好，装置通过多项电磁兼容检测认证，电快速瞬变脉冲群、静电放电、浪涌抗干扰性能均达到国家标准。

Both hardware and software of this product have continuous and comprehensive self-test function and good anti-interference capacity. This product has been certified in a number of EMC tests like electric fast transient, electrostatic discharge and surge anti-interference and complied with the relevant standards.

1.3 功能对照表

1.3 Functions

表 1.1 功能对照表

Table 1.1 Functions

稳态数据 Steady state	电压、电流有效值 RMS voltage and current	√	
	频率显示 Frequency	√	
	基波相角及矢量图 Fundamental phase angle and vector diagram	√	
	实时电压电流波形显示 Real-time voltage and current waveform	√	
	有功、无功、视在功率、功率因数 P、Q、S、PF	√	
	正向有功、反向有功、正向无功、反向无功电能 Ep+、Ep-、Eq+、Eq-	√	
	电压、电流序分量 Voltage and Current sequence components	√	
	电流、电压不平衡度 Current and voltage unbalance	√	
	电压偏差 Voltage deviation	√	
	频率偏差 Frequency deviation	√	
	谐波 Harmonics (2-63 次) (2 nd -63 rd)	电压、电流谐波有效值 Harmonic voltage/current RMS	√
		电压、电流谐波含有率 Harmonic voltage/current ratio	√
		电压、电流谐波总畸变(THD) Total harmonic distortion(THD) of voltage/current	√
		电流总需求畸变(TDD) Total demand distortion(TDD) of current	√
		电压、电流谐波相角 Harmonic voltage/current phase angle	√
		峰值因子 Crest factor	√
K 因子 K-factor		√	
奇次谐波畸变率 Odd harmonic distortion		√	
偶次谐波畸变率 Even harmonic distortion	√		

		各次谐波电能 Harmonic energy	√
		各次谐波功率 Harmonic power	√
	间谐波 Interharmonics (0.5-62.5 次) (0.5 th to 62.5 th)	电压、电流间谐波有效值 Interharmonic voltage/current RMS	√
		电压、电流间谐波含有率 Interharmonic voltage/current ratio	√
	高频次谐波 Higher harmonics	2.5kHz~8.9kHz	√
	电压闪变(短闪变、长闪变) Voltage flicker (short-term flicker & long-term flicker)		√
	电压波动 Voltage fluctuation		√
	快速电压变化 Rapid voltage change		√
	直流分量 DC volume		√
暂态数据 Temporary state	电压中断 Voltage interruption		√
	电压暂降 Voltage dip		√
	电压暂升 Voltage swell		√
	冲击电流 Inrush current		√
瞬态数据 Transient state	电压瞬态 Transient voltage		√
	电流瞬态 Transient current		√
事件记录 Event recorder	暂态事件 Temporary event	暂态事件越限触发 Trigger the threshold of temporary events	√
	稳态事件 Steady event	稳态事件越限触发 Trigger the threshold of steady events	√
	工作日志 Log	记录装置操作日志、运行状况 Record the daily operation and running conditions	√
故障录波 Waveform recorder	事件触发录波 Event-triggered recording	故障波形前后周期可设置 Settable fault wave period	√
	手动触发录波 Manual recording	录波采样点数可设置 Settable recording sampling point	√
	定时触发录波 Timed recording	录波采样点数可设置 Settable recording sampling point	√
	上位机触发录波	录波采样点数可设置 (IEC61850 协议支持)	√

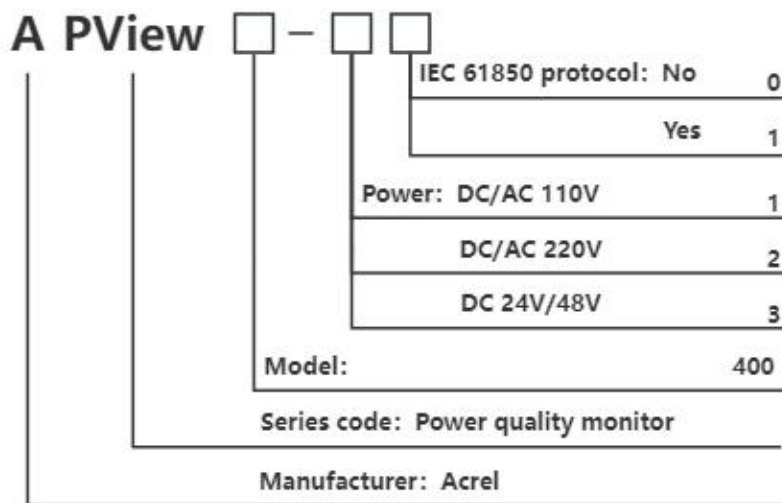
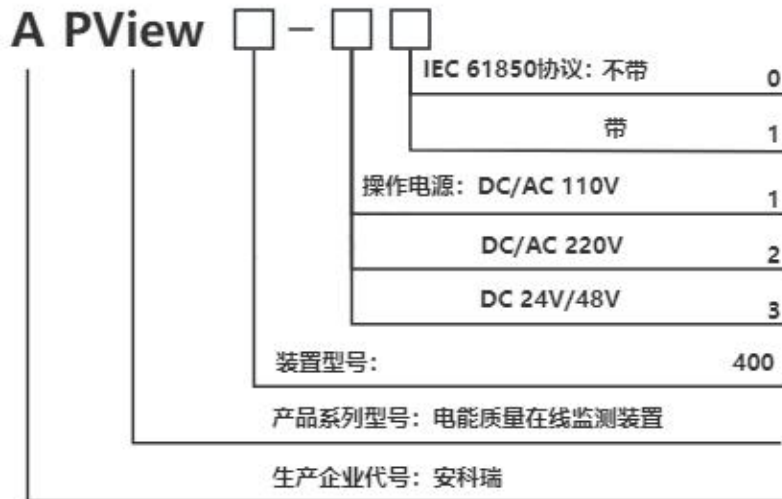
	Host-triggered recording		Settable recording sampling point (supported by IEC61850 protocol)	
通讯 Communication	IEC61850			■
	Modbus-RTU			√
	Modbus-TCP			√
	WebServer			√
对时 Timing	GPS 对时(IRIG-B) GPS timing(IRIG-B)			√
	SNTP			√
	手动对时 Manual timing			√
硬件资源 Hardware resources	AI	8	模拟量输入 Analog input	√
	DO	5	开关量输出可配置 Settable digital outputs	√
	DI	5	为无源接点，需要外接电源 Digital inputs(passive contacts requiring an external power)	√
	USB	1	用于维护 Maintenance	√
	RS485	2	用于 Modbus 通讯和 B 码对时 Modbus、IRIG-B	√
	Ethernet port	2	用于通讯和升级维护 Communication and update	√

注：√表示标配功能，■表示可选功能，×表示不具备此功能呢。

Note: √- standard function; ■- option; × - not available

1.4 装置型号命名及选型

1.4 Type



1.5 功能简介

1.5 Overview

1.5.1 人机界面功能

1.5.1 Front Panel

装置面板上采用 5 寸彩色 LCD 屏,以图形方式显示主要电能质量监测指标的实时数据。可对装置硬件时钟进行设置,并可对监测参数进行设置、修改,对装置进行时钟设置、密码设置等操作。

The panel is a 5" color LCD that graphically indicates the main power quality indexes in real time. The built-in clock can be set. The monitoring parameters can be set and modified. A user can also assign a password and perform other actions.

1.5.2 记录存储功能

1.5.2 Memory

可对监测点数据实时保存, 1min 数据(最大值、最小值、平均值、95%概率大值、均方根值)在装置上最长保存时间为 90 天, 之后按"先进先出"原则更新。

It is allowed to save monitoring data in real time. The 1min-data (e.g. maximum value, minimum value, average value, 95% probability value and RMS) can be saved for a maximum of 90 days. The memory will be updated in accordance with the principle of "first-in-first-out".

1.5.3 通讯功能

1.5.3 Communication

2 个 RS485 串行通讯接口, 支持 Modbus-RTU 协议, 能够读取所有被测量参数, 且支持 IRIG-B 码对时; 提供 2 个以太网接口, 支持 Modbus-TCP、IEC61850 MMS、FTP, 能够读取所有被测量参数。

There are 2 RS485 serial communication ports that support Modbus-RTU protocol and IRIG-B. There are 2 Ethernet ports that support Modbus-TCP, IEC61850 MMS and FTP .

1.5.4 告警功能

1.5.4 Alarm

可根据用户设定的稳态、暂态、瞬态的各项电能质量指标的限值, 启动告警功能。当某一告警触发时, 装置会记录事件记录并触发录波。

The alarm will be triggered to the user-set threshold of power quality indexes in steady, temporary and transient states. When an alarm is triggered, this product will record the event and trigger recording.

1.5.5 录波功能

1.5.5 Waveform Recorder

装置对每个告警事件都能触发录波, 并提供手动触发录波、定时触发录波和上位机触发录波功能。

Each alarm event can be recorded. There are three more triggering modes, i.e. manual recording, timed recording and host-triggered recording.

1.5.6 本地 PQDIF 文件生成功能

1.5.6 PQDIF

统计数据以 PQDIF 文件格式保存，记录数据包括 2h 内的故障录波波形和稳态数据。稳态数据包含装置每 1min 统计的"最大值""最小值""平均值""均方根值""95%概率值"整 2h 保持的数据。记录的故障录波数据和稳态数据均可通过工具软件查看。记录 1min 内"最大值""最小值""平均值""均方根值""95%概率值"生成一个记录数据点，这些数据点整 2 小时形成一个存储文件，可通过查看软件观察线路变化趋势。

The recorded data is saved in PQDIF format, including the fault waveforms and steady data within 2h. Steady-state data contains every 1 minute of "maximum value", "minimum value", "average value", "RM " and "95% probability value" recorded in 2h. The record of fault data and steady data can be viewed by the tool software. The data of "maximum value", "minimum value", "average value", "RMS" and "95% probability value" in 1min will be recorded for one data point. All these data points in 2h will be saved in a file. The trend of changes can be observed by the tool software.

1.5.7 Web 功能

1.5.7 Web Server

集成嵌入式 Web Server 功能，支持不同权限等级的用户登录访问。不同等级用户使用不同 8 位密码登录，分别为"游客": 00000000; "管理员": *****; "调试员": *****。用户可通过浏览器直接连接装置，实时查看电能质量数据和设置装置参数。

The device includes Web Sever function which supports user login access with different user levels. Different user levels use different 8-digit passwords to log in. Password: 00000000 for "Guest"; ***** for "Administrator"; ***** for "System". Users can directly connect to this product through the browser to view the power quality data and set parameters in real time.

连接方法:

Connection method:

1.将装置与电脑用网线互联;

Connect this product to your computer with the network cable.

2.进入系统设置-通讯设置菜单查看所连接以太网口对应的 IP 地址,例如: 172.22.60.99;

Check the IP address of connected Ethernet port via "System Setup - Communication", e.g. 172.22.60.99.

3.将电脑 IP 与装置 IP 设置到同一网段;

Allocate the same network segment for your computer IP and the product IP.

4.打开电脑浏览器在地址输入栏输入 IP 地址并回车。如图 1.1 所示。

Open the browser on your computer, input the IP address in the address bar as shown in Fig. 1.1.and press Enter.

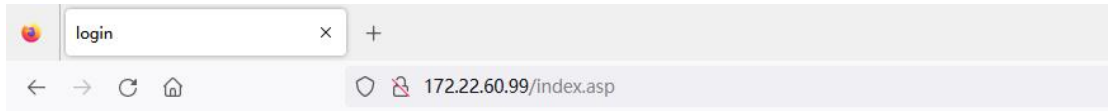


图 1.1 浏览器输入 IP 界面

Fig. 1.1 Enter the IP address in the address bar of your browser

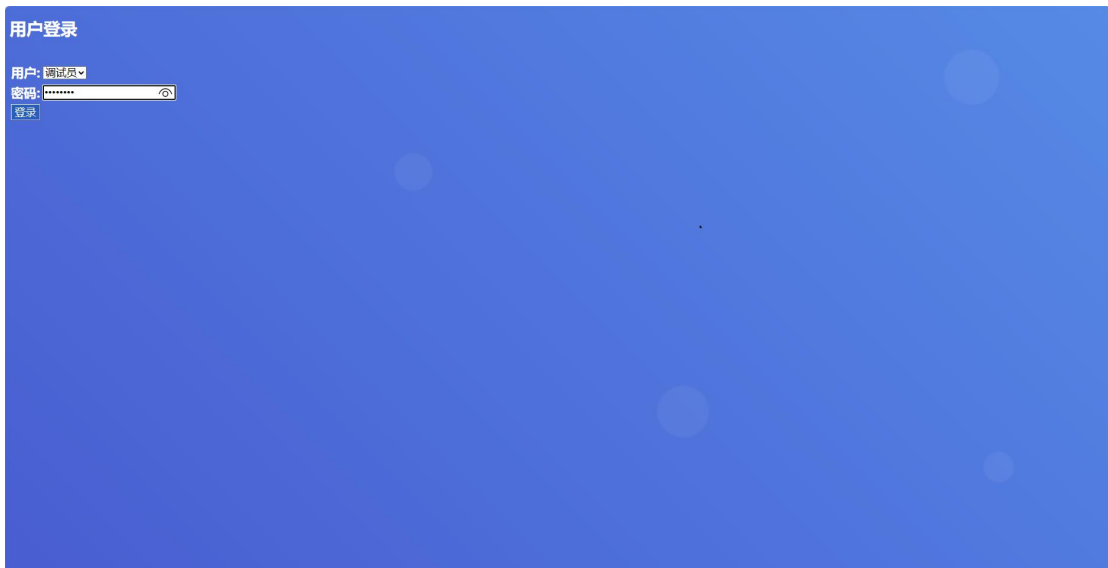


图 1.2 Web 登陆界面

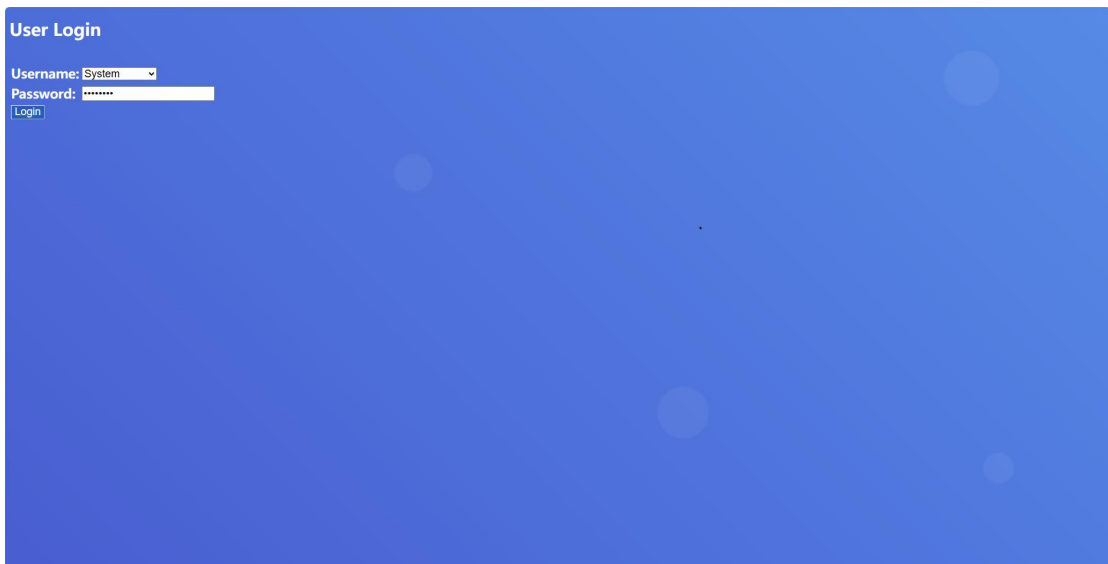


Fig. 1.2 Web server Log-in Screen

此时显示用户登录界面，用户选择身份并输入登录密码，如图 1.2。

用户登录后左侧显示功能菜单，右侧显示装置信息与数据。如图 1.3 所示。

The user login screen appears. The user selects his/her identity and input a login password on the user login screen as illustrated in Fig. 1.2.

After login, the function menu appears on the left and the product information and data are shown on the right side as illustrated in Fig. 1.3.

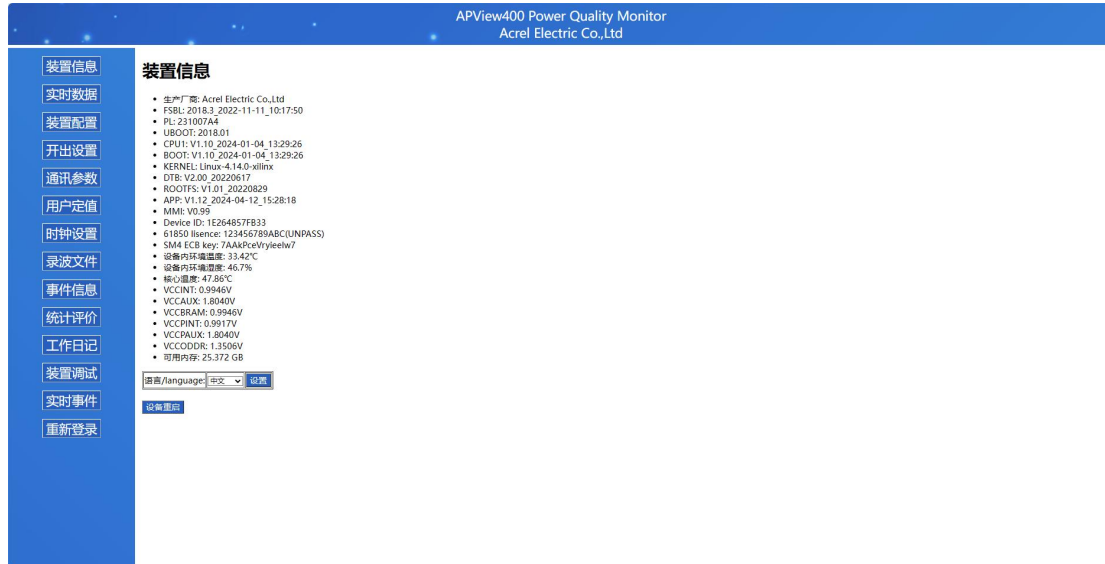


图 1.3 装置信息界面

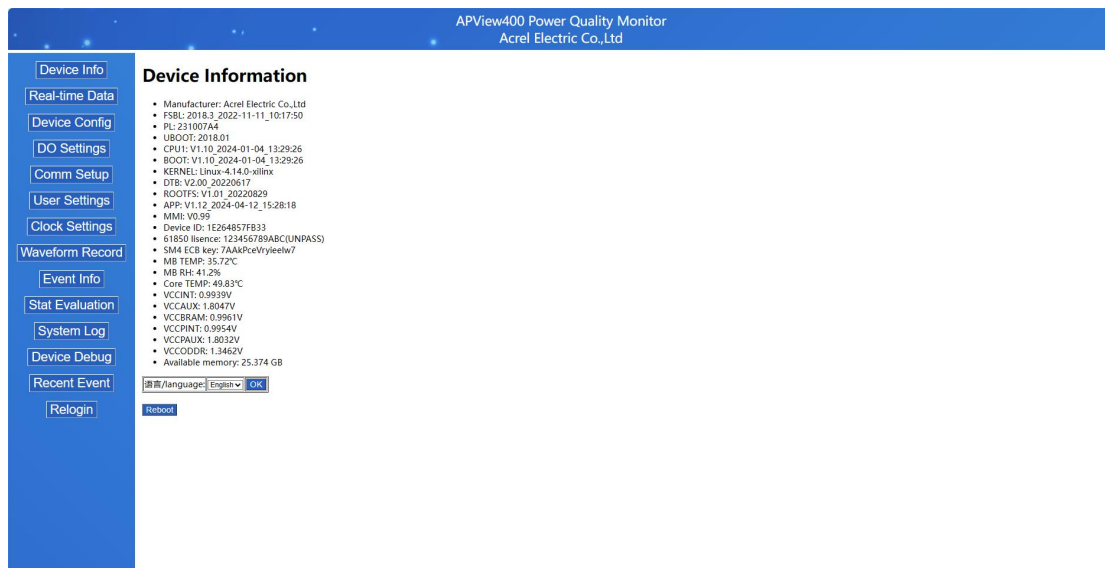


Fig. 1.3 Product Information Screen

查看实时数据:单击左侧菜单"实时数据", 右侧显示实时监测数据。

View of real-time data. Click "Real-time Data" on the left menu once. Then the real-time data will be indicated on the right.

"生成电子表格": 将显示的实时数据生成.xls 格式的表格, 鼠标单击文件名可选择打开表格或者另存。

"Generate EXCEL". Generate a spreadsheet (.xls) according to the real-time data. Click the file name to open it or save it.

"基本数据"、"功率显示"、"电能显示"、"谐波数据"等：切换不同显示数据。如图 1.3 所示。

"Basic data", "Power", "Energy", "Harmonic" and others: Make a switch to check other data as shown in Fig. 1.4.

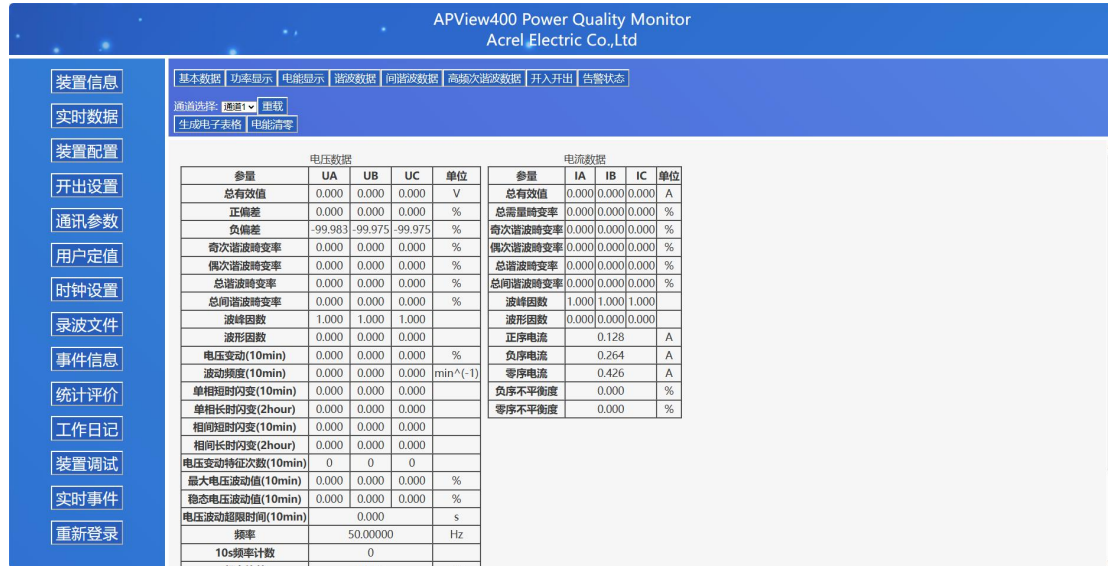


图 1.4 基本数据界面

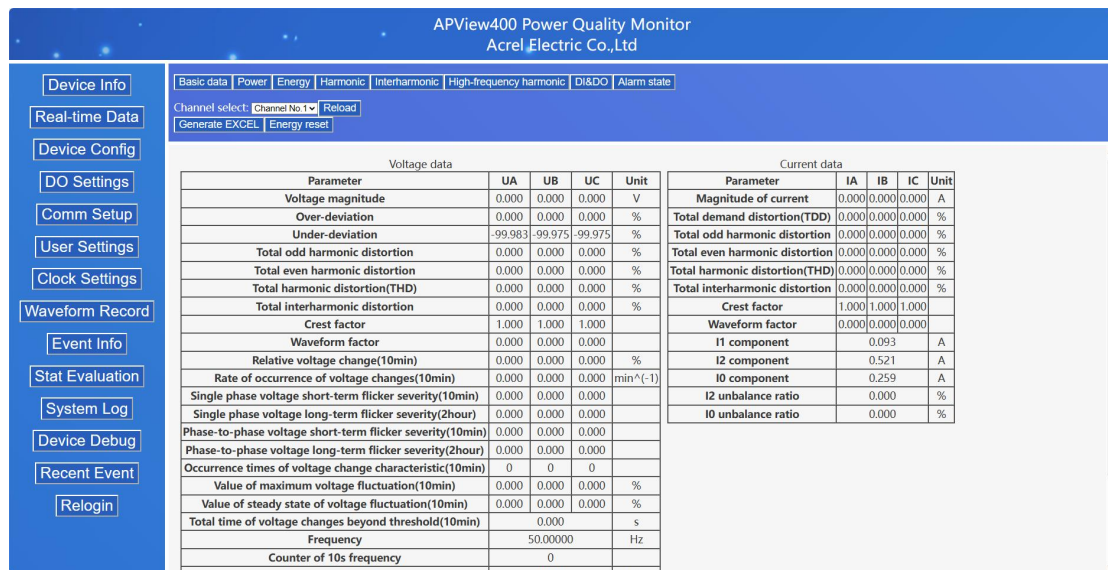


Fig. 1.4 Basic Data Screen

"录波文件": 单击左侧菜单"录波文件", 再选择对应的事件记录, 可查看该事件记录的波形。

Waveform Record. Click "Wave Record" on the left and select the corresponding Events to check the recorded waveform.

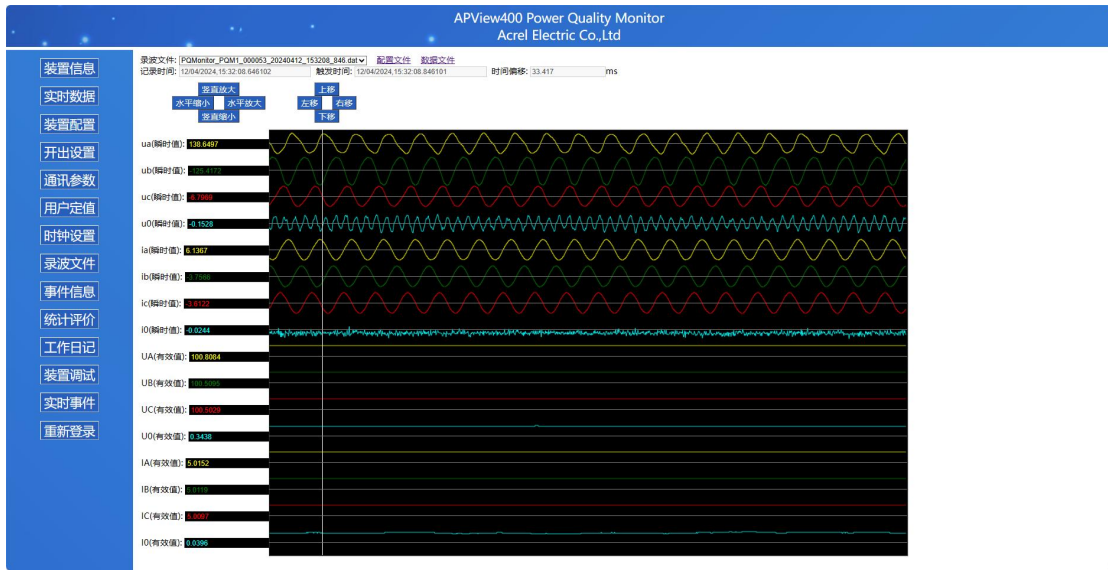


图 1.5 波形界面

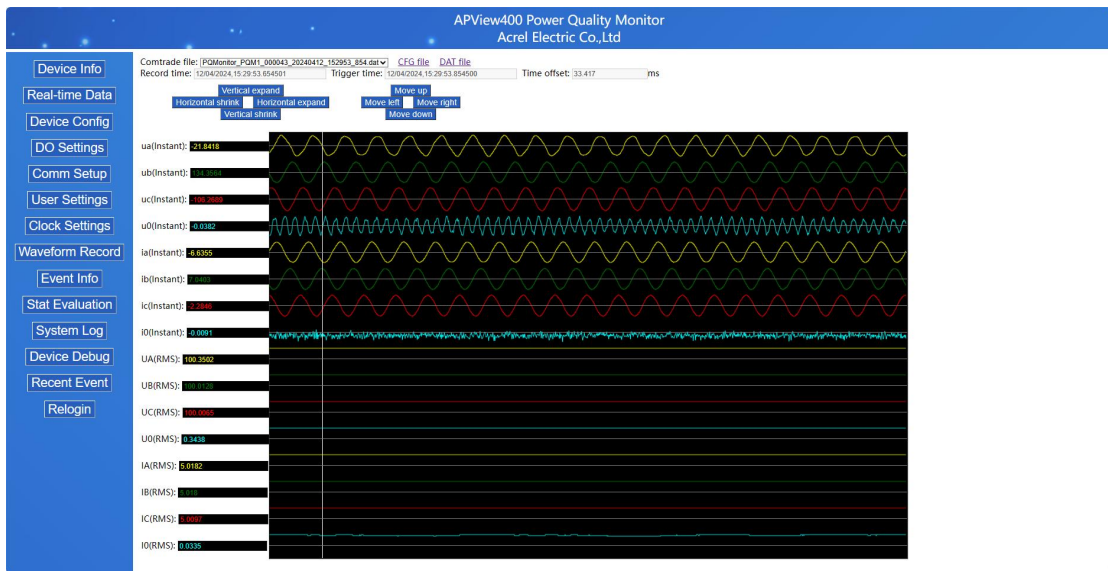


Fig. 1.5 Waveform Screen

2 技术参数

2 Technical parameter

2.1 工作电源

2.1 Power supply

额定值: AC/DC220、AC/DC110V或DC24/48V;

允许偏差: $-20\% \sim +20\%$;

功率消耗: 不大于15W;

Rated: AC/DC220, AC/DC110V or DC24V/48V

Permissible deviation: $-20\% \sim +20\%$

Power consumption: $\leq 15W$

2.2 交流电流输入

2.2 AC current

输入方式: 电流互感器输入;

额定值 I_n : 5A;

测量范围: $0 \sim 1.2I_n$;

功率消耗: 不大于0.5VA/路;

过载能力: $1.2I_n$ 连续工作;
20倍额定电流允许1s。

Input mode: Current transformer input

Rated: 5A

Measuring range: $0 \sim 1.2I_n$

Power consumption: $\leq 0.5VA$ (single phase)

Overload capacity: $1.2I_n$, continuous working
20 times for 1 second

2.3 交流电压输入

2.3 AC voltage

输入方式: 电压互感器输入;

额定值 U_n : 220V/380V;

测量范围: $0 \sim 1.2U_n$;

功率消耗: 不大于0.5VA/路;

过载能力: $1.2U_n$ 连续工作;
4倍额定电压允许1s。

Input mode: Voltage transformer input
Rated: 220V/380V
Measuring range: 0-1.2Un
Power consumption: $\leq 0.5VA$ (single phase)
Overload capacity: 1.2Un, continuous working
4 times for 1seconds

2.4 开关量输入

2.4 Digital input

额定电压: AC/DC220V、AC/DC110V或DC24V/48V;
输入方式: 无源接点, 需要外接电源;
Rated voltage: AC/DC220V, AC/DC110V or DC24V/48V
Input mode: Passive contacts, external power supply required

2.5 开关量输出

2.5 Digital output

机械寿命: ≥ 10000 次;
输出方式: 无源干接点;
接通容量: $\leq 4000W$ 或 $\leq 384VA$;
导通电流: 连续 $\geq 16A$ (AC250V/DC24V), 短时(200ms) $\geq 30A$;
Mechanical service life: ≥ 10000
Output mode: Passive contacts
Switching capacity: $\leq 4000W$ or $\leq 384VA$
On-state current: $\geq 16A$ (AC250V/DC24V) in the continuous mode;
 $\geq 30A$ for a short term (200ms)

2.6 通讯接口

2.6 Communication port

2.6.1 以太网

2.6.1 Ethernet

接口速率: 10/100M 自适应;
接口类型: 10/100Base—T;
支持TCP/IP, FTP 协议;
Speed: 10/100M, adaptive
Type: 10/100Base—T

Compatible with TCP/IP, FTP protocol

2.6.2 RS485 接口

2.6.2 RS485 port

接口速率： 300~57600bps；

带光电隔离。

Speed: 300-57600bps

With the optical isolation

2.7 监测精度对照表

2.7 Monitor accuracy

基本功能 Basic functions		精确度 Accuracy	
稳态数据 Steady state	电压有效值 RMS Voltage	±0.1%	
	电流有效值 RMS Current	±0.1%	
	有功、无功、视在功率 P,Q,S	±0.2%	
	功率因数 Power factor	±0.5%	
	电能 Ep+,Ep-,Eq+,Eq-	0.5 级 Class 0.5	
	电压偏差 Voltage deviation	0.1%	
	频率偏差 Frequency deviation	±0.001Hz	
	三相不平衡 Three-phase unbalance	电压不平衡度 Voltage unbalance	±0.15%
		电流不平衡度 Current unbalance	±1%
	谐波 (2-63 次) Harmonics (2nd -63rd)	电压谐波有效值 Harmonic voltage RMS	$U_{hN} \geq 1\%U_N$: 误差±5%; 误差计算公式: $\frac{U_h - U_{hN}}{U_{hN}} \times 100\%$ When $U_{hN} \geq 1\%U_N$, the error is ±5%. Error calculation: $\frac{U_h - U_{hN}}{U_{hN}} \times 100\%$
$U_{hN} < 1\%U_N$: 误差±0.05%; 误差计算公式: $\frac{U_h - U_{hN}}{U_N} \times 100\%$ When $U_{hN} < 1\%U_N$, the error is ±0.05%.			

	电流谐波有效值 Harmonic current RMS		Error calculation: $\frac{U_h - U_{hN}}{U_N} \times 100\%$	
			$I_{hN} \geq 3\%I_N$: 误差±5%; 误差计算公式: $\frac{I_h - I_{hN}}{I_{hN}} \times 100\%$ When $I_{hN} \geq 3\%I_N$, the error is ±5%. error calculation: $\frac{I_h - I_{hN}}{I_{hN}} \times 100\%$	
			$I_{hN} < 3\%I_N$: 误差±0.15%; 误差计算公式: $\frac{I_h - I_{hN}}{I_{hN}} \times 100\%$ When $I_{hN} < 3\%I_N$, the error is ±0.15%. Error calculation: $\frac{I_h - I_{hN}}{I_{hN}} \times 100\%$	
	电压间谐波有效值 Interharmonic voltage RMS		$U_{hN} \geq 1\%U_N$: 误差±5%; 误差计算公式: $\frac{U_h - U_{hN}}{U_{hN}} \times 100\%$ When $U_{hN} \geq 1\%U_N$, the error is ±5%. Error calculation: $\frac{U_h - U_{hN}}{U_{hN}} \times 100\%$	
			$U_{hN} < 1\%U_N$: 误差±0.05%; 误差计算公式: $\frac{U_h - U_{hN}}{U_N} \times 100\%$ When $U_{hN} < 1\%U_N$, the error is ±0.05%. Error calculation: $\frac{U_h - U_{hN}}{U_N} \times 100\%$	
	间谐波 (0.5-62.5次) Interharmonics (0.5th to 62.5th)	电流间谐波有效值 Interharmonic current RMS		$I_{hN} \geq 3\%I_N$: 误差±5%; 误差计算公式: $\frac{I_h - I_{hN}}{I_{hN}} \times 100\%$ When $I_{hN} \geq 3\%I_N$, the error is ±5%. error calculation: $\frac{I_h - I_{hN}}{I_{hN}} \times 100\%$
				$I_{hN} < 3\%I_N$: 误差±0.15%; 误差计算公式: $\frac{I_h - I_{hN}}{I_{hN}} \times 100\%$ When $I_{hN} < 3\%I_N$, the error is ±0.15%. Error calculation: $\frac{I_h - I_{hN}}{I_{hN}} \times 100\%$
	高频谐波 Higher harmonics		2.5kHz~8.9kHz	
	电压闪变 Voltage flicker		±5%	
	电压波动 Voltage fluctuation		±0.2%Un	

	电压快速变化 Rapid voltage change		$\pm 0.2\%U_N$
	手动录波及定时录波 Manual/Timed recording		采样点可设/周波 Settable sampling points/ cycle
暂态数据 Temporary state	事件类型 Event type	电压暂降 Voltage dip	幅值误差小于 $\pm 0.2\%$ ，时间误差小于 $\pm 20\text{ms}$ Amplitude error: $< \pm 0.2\%$; time error: $< \pm 20\text{ms}$
		电压暂升 Voltage swell	幅值误差小于 $\pm 0.2\%$ ，时间误差小于 $\pm 20\text{ms}$ Amplitude error: $< \pm 0.2\%$; time error: $< \pm 20\text{ms}$
		短时中断 Voltage interruption	幅值误差小于 $\pm 0.2\%$ ，时间误差小于 $\pm 20\text{ms}$ Amplitude error: $< \pm 0.2\%$; time error: $< \pm 20\text{ms}$
		冲击电流 Inrush current	幅值误差小于 $\pm 0.2\%$ ，时间误差小于 ± 1 周波 Amplitude error: $< \pm 0.2\%$; Time error: $< \pm 20\text{ms}$
	暂态事件录波 Temporary event record		1024 点/周波 1024 points/ cycle
瞬态数据 Transient state	电压瞬态 Transient voltage		20us
	电流瞬态 Transient voltage		20us
	瞬态录波 Transient event record		1024 点/周波 1024 points/ cycle
定时 Timing	IRIG-B		定时绝对精度: $\pm 1\text{ms}$, 时钟守时精度 $\pm 1\text{s}/24\text{h}$ Absolute timing accuracy: $\pm 1\text{ms}$; clock accuracy: $\pm 1\text{s}/24\text{h}$
	SNTP		定时绝对精度: $\pm 1\text{ms}$, 时钟守时精度 $\pm 1\text{s}/24\text{h}$ Absolute timing accuracy: $\pm 1\text{ms}$; clock accuracy: $\pm 1\text{s}/24\text{h}$

注 1: 表中 U_N 为标称电压, I_N 为标称电流。

Note 1. U_N -nominal voltage; I_N - nominal current

注 2: U_h 为第 h 次(间)谐波电压实际测试值; U_{hN} 为第 h 次(间)谐波电压给定值。

Note 2. U_h —measured harmonic/ interharmonic voltage of cycle h; U_{hN} -given harmonic/ interharmonic voltage of cycle h

注 3: I_h 为第 h 次(间)谐波电流实际测试值; I_{hN} 为第 h 次(间)谐波电流给定值。

Note 3. I_h —measured harmonic/ interharmonic current of cycle h; I_{hN} -given harmonic/ interharmonic current of cycle h

2.8 依据标准

2.8 Reference standard

GB/T 14549 电能质量 公用电网谐波；

GB/T 14549 Quality of electric energy supply—Harmonics in public supply network

GB/T 18481 电能质量暂时过电压和瞬态过电压；

GB/T 18481 Power quality—Temporary and transient overvoltages

GB/T 19862 电能质量 监测设备通用要求；

GB/T 19862 General requirements for monitoring equipment of power quality

GB/T 12325 电能质量 供电电压允许偏差；

GB/T 12325 Power quality— Deviation of supply voltage

GB/T 12326 电能质量 电压波动和闪变；

GB/T 12326 Power quality—Voltage fluctuation and flicker

GB/T 15543 电能质量 三相电压允许不平衡度；

GB/T 15543 Power quality—Three-phase voltage unbalance

GB/T 15945 电能质量 电力系统频率允许偏差；

GB/T 15945 Power quality—Frequency deviation for power system

GB/T 24337 电能质量 公用电网间谐波；

GB/T 24337 Power quality— Interharmonics in public supply network

IEC 61000-4-30 电能质量测量方法；

IEC 61000-4-30 Power quality measurement methods

IEC 61000-4-15 闪变仪-功能和设计规范；

IEC 61000-4-15 Flickermeter—Functional and design specifications

GB/T 2423.10 环境试验 第2部分：试验方法 试验Fc:振动(正弦)；

GB/T 2423.10 Environmental testing— Part 2: Tests methods— Test Fc: Vibration (sinusoidal)

GB/T 2423.5 环境试验 第2部分：试验方法 试验Ea和导则：冲击；

GB/T 2423.5 Environmental testing— Part 2: Tests methods—Test Ea and guidance: Shock

GB/T 17626.4(IEC 61000-4-4:2004) 电磁兼容 试验和测量技术 电快速瞬变脉冲群抗扰度试验；

GB/T 17626.4(IEC 61000-4-4:2004) Electromagnetic compatibility— Testing and measurement techniques— Electrical fast transient/burst immunity test

GB/T 17626.3(IEC 61000-4-3:2002) 电磁兼容 试验和测量技术 射频电磁场辐射抗扰度试验；

GB/T 17626.3(IEC 61000-4-3:2002) Electromagnetic compatibility— Testing and measurement techniques—Radiated, radio-frequency, electromagnetic field immunity test

GB/T 17626.2(IEC 61000-4-2:2001) 电磁兼容 试验和测量技术 静电放电抗扰度试验:

GB/T 17626.2(IEC 61000-4-2:2001) Electromagnetic compatibility— Testing and measurement techniques—Electrostatic discharge immunity test

GB/T 17626.5(IEC 61000-4-5:2005) 电磁兼容 试验和测量技术 浪涌(冲击)抗扰度试验:

GB/T 17626.5(IEC 61000-4-5:2005) Electromagnetic compatibility— Testing and measurement techniques—Surge immunity test

GB/T 2423.2 电工电子产品环境试验 第2部分: 试验方法试验B: 高温:

GB/T 2423.2 Environmental testing for electric and electronic products— Part 2: Test methods— Tests B: Dry heat

GB/T 2423.1 电工电子产品环境试验 第2部分: 试验方法 试验A: 低温:

GB/T 2423.1 Environmental testing for electric and electronic products— Part 2: Test methods— Tests A: Cold

GB/T 2423.4 电工电子产品环境试验 第2部分: 试验方法试验Db(12h+12h循环);

GB/T 2423.4 Environmental testing for electric and electronic products— Part 2: Test methods— Test Db: Damp heat, cyclic (12h + 2h cycle)

GB/T 4208 外壳防护等级(IP代码)。

GB/T 4208 Degrees of protection provided by enclosure (IP code)

2.9 工作环境

2.9 Working conditions

正常工作温度: $-10^{\circ}\text{C} \sim +55^{\circ}\text{C}$;

贮存温度: $-30^{\circ}\text{C} \sim +80^{\circ}\text{C}$;

相对湿度: 5%~95%;

大气压力: 86kPa~106kPa;

海拔: ≤ 2500 米;

防护等级: IP51。

Normal working temperature: $-10^{\circ}\text{C} \sim +55^{\circ}\text{C}$

Storage temperature: $-30^{\circ}\text{C} \sim +80^{\circ}\text{C}$

Relative humidity: 5%-95%

Atmospheric pressure: 86kPa-106kPa

Altitude: $\leq 2500\text{m}$

Degree of protection: IP51

2.10 安全性能

2.10 Safety features

2.10.1 绝缘强度

2.10.1 Insulating properties

装置能承受有效值为2kV、频率为50Hz、历时1min 的绝缘强度试验，而无击穿和闪络现象。

Pass the Insulating properties test at 2KV and 50Hz for 1min without breakdown or flashover.

2.10.2 绝缘电阻

2.10.2 Insulation resistance

用开路电压为500V 的兆欧表测量装置的绝缘电阻值，正常试验大气条件下各等级的各回路绝缘电阻不小于20MΩ。

Measure the insulation resistance by a megohmmeter with an open-circuit voltage of 500V. The insulation resistance of circuit at different levels shall not be less than 20MΩ under normal atmospheric conditions.

2.10.3 冲击电压

2.10.3 Impulse voltage

在正常试验大气条件下，装置的电源输入回路、交流输入回路、输出触点回路对地以及回路之间能承受1.2/50μs 的标准雷电波的标准短时冲击电压试验，开路试验电压5kV。

Conduct the short-term impulse voltage test among the power input circuit, the AC input circuit and the digital output circuit and between such circuits and the ground at the standard lightning wave of 1.2/50μs and an open-circuit voltage of 5kV under normal atmospheric conditions.

2.10.4 耐湿热性能

2.10.4 Damp and heat resistance

装置应能承受GB/T 2423.9-2001 规定的恒定湿热试验。试验温度+40℃±2℃、相对湿度(93±3)%，试验时间为48小时，在试验结束前2小时内，用500V直流兆欧表，测量各外引带电回路部分外露非带电金属部分及外壳之间、以及电气上无联系的各回路之间的绝缘电阻应不小于1.5MΩ；介质耐压强度不低于介质强度试验电压幅值的75%。

Conduct the steady-state damp and heat test at +40℃±2℃ and (93±3)%RH for 48h in compliance with the provisions of GB/T 2423.9-2001. During the last 2 hours before the

end of the test, measure the insulation resistance and the dielectric strength between the exposed non-conductive metal parts and enclosures of all external live circuits, and between the circuits which are not electrically connected with a 500VDC megohmmeter. Such insulation resistance shall be no less than 1.5MΩ and the dielectric strength shall not be less than 75% of the dielectric strength test voltage.

2.11 电磁兼容性能与机械性能

2.11 EMC and mechanical properties

2.11.1 电磁兼容性能

2.11.1 EMC performance

电压暂降和短时中断抗扰度满足 GB/T 17626.11 和 GB/T17626.29 的要求；

The immunity to voltage dip and the short-term interruption shall meet requirements of GB/T 17626.11 and GB/T17626.29 respectively.

射频电磁场辐射抗扰度应按照 GB/T 17626.3(IEC 61000-4-3:2002)中规定，满足严酷等级 4 级的要求；

Radio-frequency electromagnetic field radiation immunity shall meet requirements of Severity Class IV in GB/T 17626.3(IEC 61000-4-3:2002).

电快速瞬变脉冲群抗扰度应按照 GB/T17626.4(IEC 61000-4-4:2004)中规定，满足严酷等级 4 级的要求；

The immunity of electric fast transient pulse group shall meet requirements of Severity Class IV in GB/T 17626.4(IEC 61000-4-4:2004).

静电放电抗扰度应按照 GB/T 17626.2(IEC 61000-4-2:2001)中规定，满足严酷等级 4 级的要求；

Electrostatic discharge immunity shall meet requirements of Severity Class IV in GB/T 17626.2(IEC 61000-4-2:2001).

浪涌抗扰度应按照 GB/T 17626.5(IEC 61000-4-5:2005)中规定，满足严酷等级 4 级的要求；

The surge immunity shall meet requirements of Severity Class IV in GB/T 17626.5(IEC 61000-4-5:2005).

工频磁场抗扰度应按照 GB/T 17626.8(IEC 61000-4-8:2001)中规定，满足严酷等级 4 级的要求；

Power frequency magnetic field immunity shall meet requirements of Severity Class IV in GB/T 17626.8(IEC 61000-4-8:2001).

射频场感应的传导骚扰抗扰度应按照 GB/T 17626.6(IEC 61000-4-3:2002)中规定，满足严酷等级 3 级的要求；

Disturbance immunity of RF Field Induction conduction shall meet requirements of Severity Class III in GB/T 17626.6(IEC 61000-4-3:2002).

振荡波抗扰度应按照 GB/T 17626.12 中规定，满足严酷等级 4 级的要求。

Oscillatory waves immunity shall meet requirements of Severity Class IV in GB/T 17626.12.

2.11.2 机械振动

2.11.2 Mechanical vibration

装置能承受GB/T2423.10中规定的振动耐久能力试验。

This product shall pass the vibration durability test in compliance with the provisions of GB/T2423.10.

2.11.3 机械冲击

2.11.3 Mechanical shock

装置能承受GB/T2423.5 中规定的冲击响应试验。

This product shall pass the impact response test in compliance with the provisions of GB/T2423.5.

3 机械结构与电气安装

3 Mechanical structure and installation

3.1 开孔尺寸与安装方式

3.1 Hole size and installation method

装置采用嵌入式安装，首先在柜（屏）体面板上按 3.1 所示开孔，再将装置按图 3.2 所示放入开孔中，直到装置面板靠住柜（屏）的面板。再安装固定支架，螺丝旋入螺丝孔，使装置牢固在柜（屏）上。

The embedded installation is adopted for this product. First, drill holes on the panel of a distribution cabinet as shown in Fig. 3.1. Second, place this product into these holes until the panel of product is against the panel of the distribution cabinet as shown in Fig. 3.2. Finally, install the mounting slide bars, then insert screws and tighten them to fix this product.

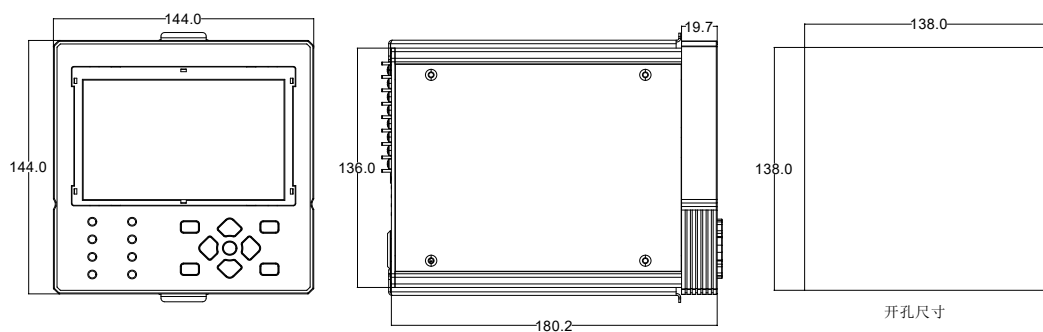


图 3.1 外形及开孔尺寸图

Fig. 3.1 Outline and size diagram

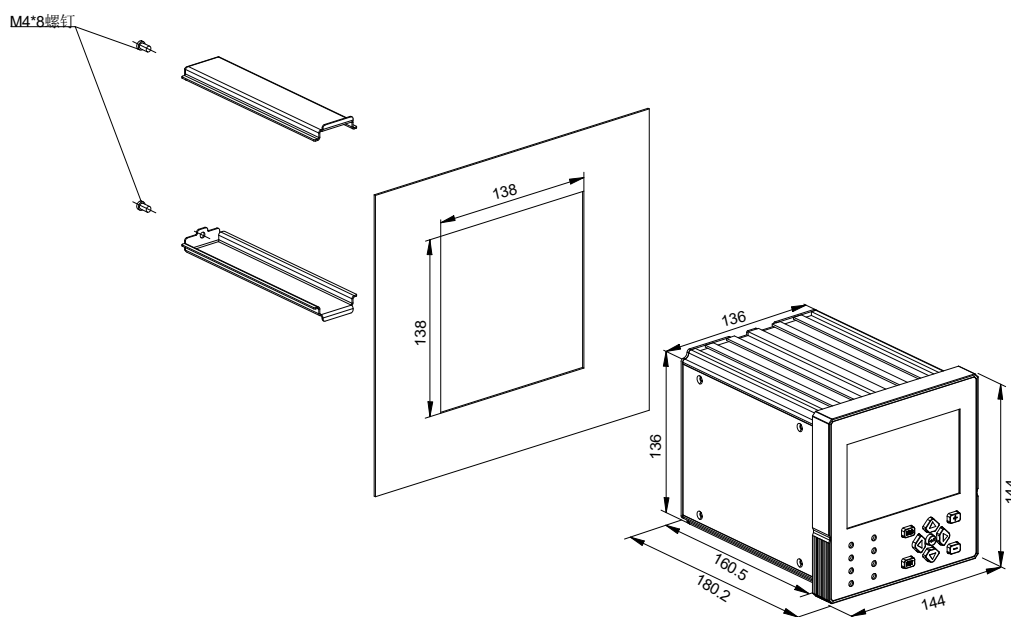


图 3.2 安装示意图

Fig. 3.2 Installation diagram

3.2 背部端子图

3.2 Back terminals

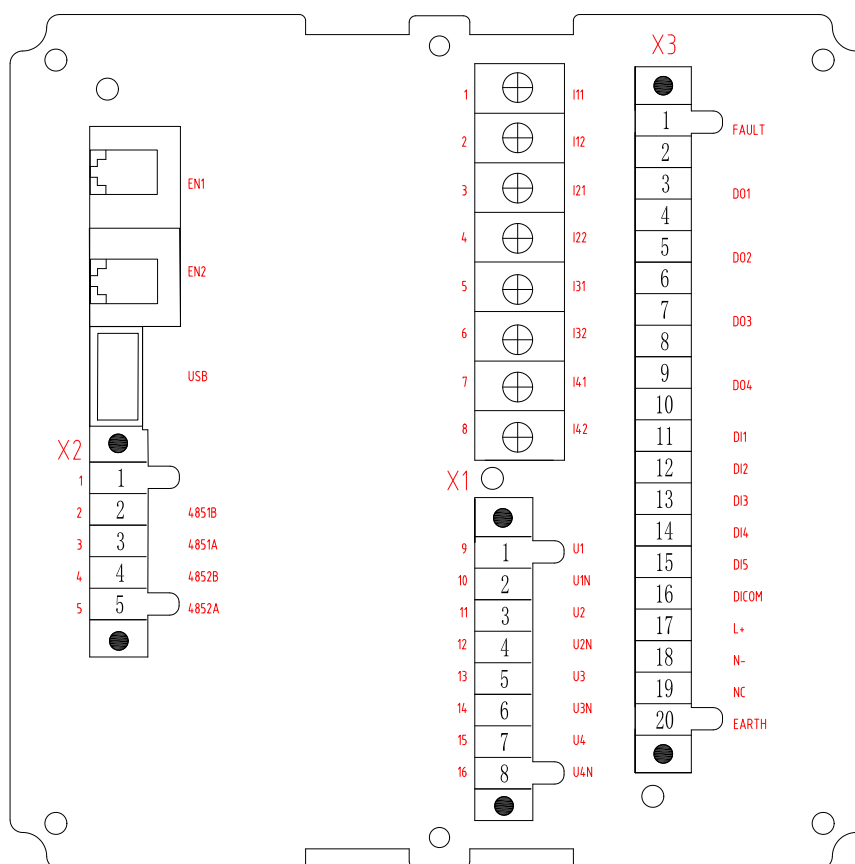


图 3.3 背部端子图

Fig. 3.3 Back terminals

X1 端子: X1.1~X1.6 为三相电流输入;

X1.9~X1.14 为三相电压输入;

X1.7~X1.8 为外接零序电流输入;

X1.15~X1.16 为外接零序电压输入。

Terminal X1: X1.1~X1.6--3-phase current inputs;

X1.9~X1.14--3-phase voltage inputs;

X1.7~X1.8--external zero-sequence current;

X1.15~X1.16--external zero-sequence voltage;

X2 端子: 4851B、4851A, 第 1 路 RS485 串行通讯接口 (支持 IRIG-B 对时协议);

4852B、4852A, 第 2 路 RS485 串行通讯接口 (支持 IRIG-B 对时协议);

Terminal X2: 4851A, 4851B--The first RS485 communication port(support IRIG-B);

4852A, 4852B--The second RS485 communication port(support IRIG-B);

X3 端子： 开关量输入、继电器出口、辅助电源。

继电器出口，其中 X6.1 和 X6.2 为一组常闭继电器触点，为装置异常出口；
X6.3-X6.4、X6.5-X6.6、X6.7-X6.8、X6.9-X6.10 为 4 组常开继电器触点，支持
功能自定义。

开关量输入，X3.11~X3.15 为 5 个 DI 输入端子；X3.16 为信号公共端。

辅助电源，X3.17~X3.20 是装置的辅助电源，X3.20 为装置接地口(**装置安装时
请务必接地**)。

Terminal X3: Digital inputs and relay outputs.

The relay outputs includes X6.1-X6.2 as a sets of normally closed relay contacts, serving as the device's abnormal outlet. Terminals X6.3-X6.4, X6.5-X6.6, X6.7-X6.8, and X6.9-X6.10 are four sets of normally open relay contacts that support customized functionality.

The digital input comprises X3.11~X3.15 as five DI input terminals, while X3.16 serves as the signal common terminal.

Terminals X3.17~X3.20 are the power supply for the device, with X3.20 serving as the grounding port for the device (**Please ensure grounding during installation**).

ETH1、ETH2: 以太网接口。

ETH1, ETH2 – Ethernet port

USB: USB 维护口

USB - USB maintenance port

3.3 接线方式

3.3 Wiring

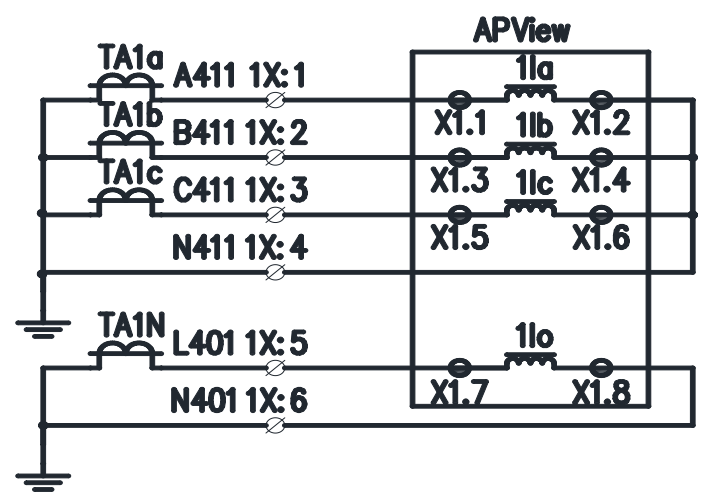


图 3.5 3CT 电流接线
Fig. 3.5 3CT Current wiring

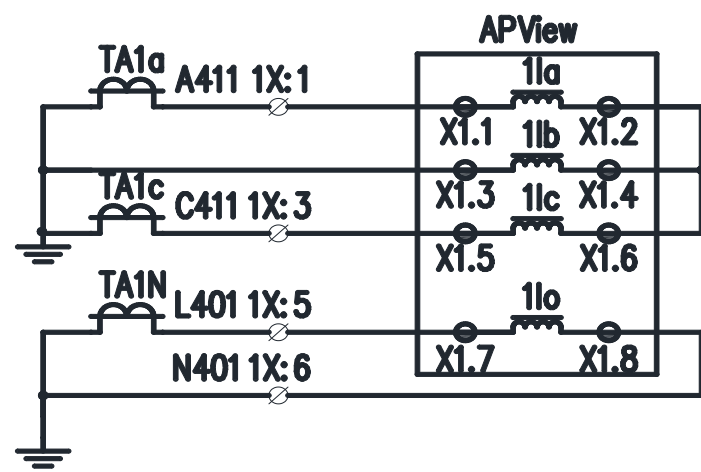


图 3.6 2CT 电流接线
Fig. 3.6 2CT Current wiring

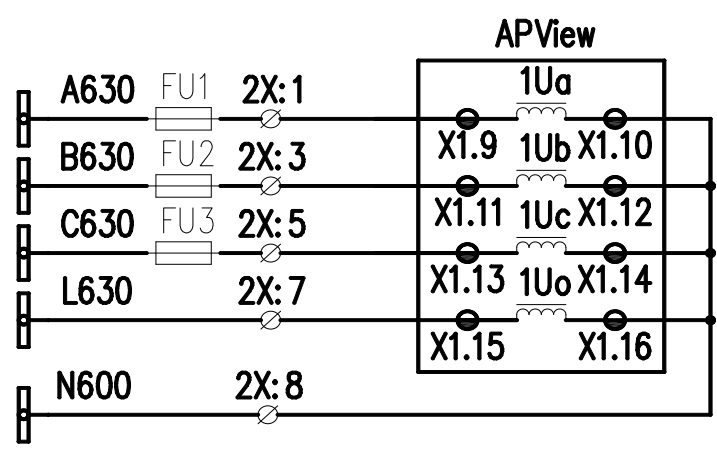


图 3.7 3PT 电压接线
Fig. 3.7 3PT Voltage wiring

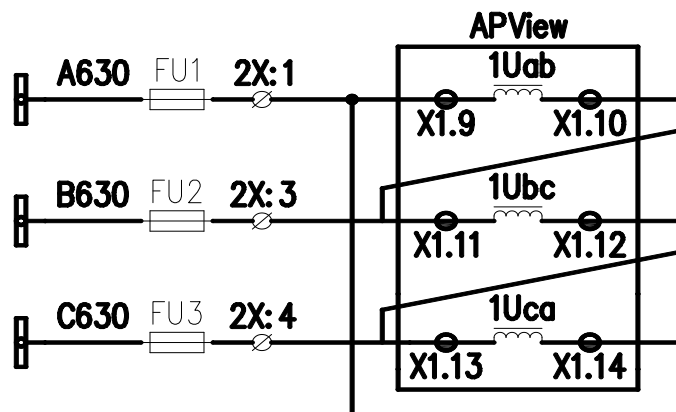


图 3.8 2PT 电压接线
Fig. 3.8 2PT Voltage wiring

3.4 接地

3.4 Ground

为保证装置的安全运行和人身安全，装置外壳必须与变电站、电厂的地网可靠连接。同时为保证装置在强电磁干扰环境下可靠运行，考虑了许多隔离、滤波、安全措施，这些措施要发挥作用，装置必须有良好的接地。因此，装置的接地非常重要。装置在 X3 端子上设有接地端子 X3.20（标志为 EARTH），必须用不小于 4mm² 专用接地导线(黄绿双色)将该端子与大地可靠连接。

In order to ensure the safety of this product and its operators, the casing shall be connected to the grounding grid of substation or power plant reliably. For reliable operation at a workplace exposed to strong electromagnetic interference, isolation, filtering and safety measures have been incorporated into this product. However, the effect of these measures depends on the correct grounding of this product. Therefore, grounding is crucial. Grounding port X3.20 (label: EARTH) is provided at terminal X3, which must be reliably grounded with a 4mm² or bigger grounding conductor (yellow-green).

3.5 电源

3.5 Power supply

装置支持交流或直流电源输入，支持AC/DC110V、AC/DC220V和DC24V/48V 三种规格(额定值)，工作范围是(80%~120%)额定值。在装置上电前，必须核对装置侧面的铭牌，以确保装置实际提供的电源与现场的电源范围一致，防止损坏装置。电源必须稳定供电，防止装置断电导致未记录故障的情况。

This product can work at the rating of AC/DC110V, AC/DC220V or DC24V/48V within an operating range of 80% to 120%. Before powering on this product, check the

nameplate on the side and ensure that the actual power supply matches the nominal range of this product to prevent damages to this product. The power supply must be stable to prevent the device from shutting down due to power failure, which may lead to unrecorded faults.

3.6 模拟量输入回路

3.6 Analog input

装置用交流电流回路必须用可靠压接的不小于 2.5mm^2 的带色标的导线连接至屏、柜的电流输入端子处，装置端子上的螺丝必须有弹簧垫圈并拧紧，以防止交流电流回路开路；交流电压回路必须用可靠压接的不小于 1.5mm^2 的导线连接至屏、柜的电流输入端子处。

The current input terminals of device shall be connected to the AC current circuit of the distribution board or cabinet with a color-labeled wire of min. 2.5mm^2 reliably crimped. The fixing screws of terminals shall be provided with spring washers and tightened to prevent open circuit. The voltage input terminals of device shall also be connected to the AC voltage circuit of the distribution board or cabinet with a color-labeled wire of min. 1.5mm^2 reliably crimped.

3.7 通讯端口的连接

3.7 Communication port

装置提供2个以太网通讯网口EN1、EN2，为10/100M的网口（具有换相功能），采用RJ45接口。装置提供2个RS485串行通讯接口（具有IRIG-B码对时功能）4851B/1A、4852B/2A，支持300~57600bps，通讯连接时选用屏蔽双绞线以提高可靠性。

This product is equipped with 10/100M Ethernet ports EN1, EN2 and EN3 (with phase switching function) using RJ45 interface. There are two RS485 serial communication ports (with the IRIG-B synchronization function), i.e. 4851B/2B and 4852B/2a, within the range of 300 to 57600bps. And the communication connection is made through a shielded twisted pair to improve reliability.

4 人机界面

4 Human Machine Interface(HMI)

装置的人机交互包括液晶显示、LED指示灯、按键。装置液晶采用5寸彩色LCD，分辨率为800*480，可以显示实时数据、电能质量、事件记录、用户定值、系统设置、装置调试等数据。

The HMI of this product include a LCD, LED lamps and buttons. The 5" color LCD with a resolution of 800*480 shows metering, power quality, events, parameters, system setup, Debug and other data.



图 4.1 前面板说明

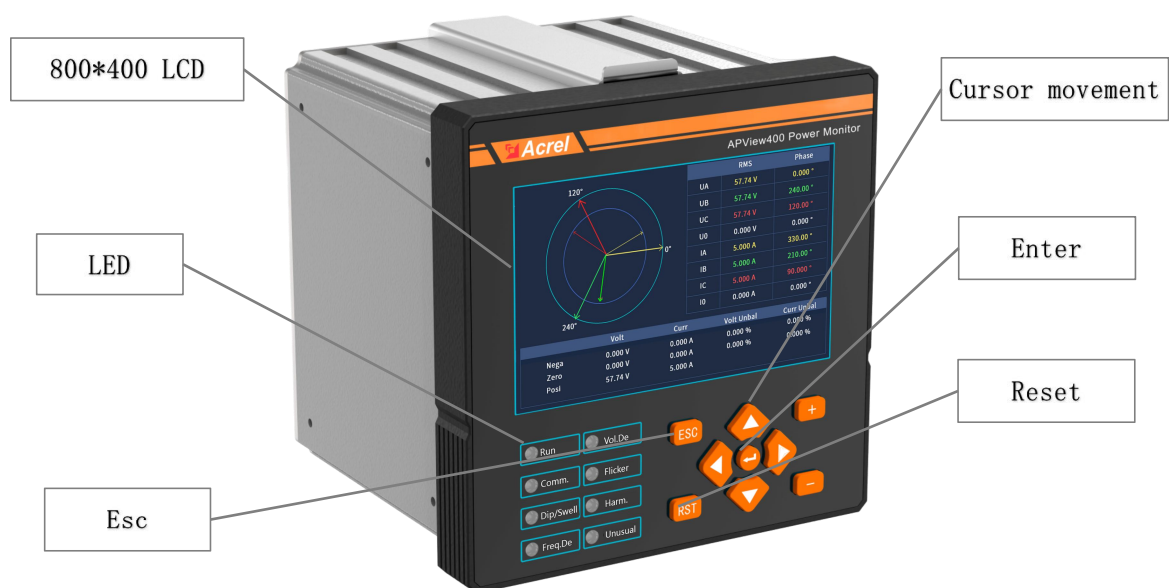


Fig. 4.1 Front Panel

4.1 按键

4.1 Buttons

表 4.1 按键功能说明

Table 4.1 Function Description of Buttons

按键 Button	主要功能 Main functions	按键 Button	主要功能 Main functions
▲	向上移动选择或数字增大 Select the one above or increase the value	◀	向左移动选项或页面前翻 Select the left one or scroll to the last screen
▼	向下移动选择或数字减小 Select the one below or decrease the value	▶	向右移动选项或页面后翻 Select the right one or scroll to the next screen
ESC	返回 Escape	+	向右移动波形图上的垂直光标 Move the vertical cursor to the right on the waveform graph.
RST	复位 Reset	—	向左移动波形图上的垂直光标 Move the vertical cursor to the left on the waveform graph.
↵	确认 Enter		

4.2 面板指示灯

4.2 LED lamps

LED 灯用来指示装置的运行状态、通讯状态和电能质量指标。

LED lamps indicate the running conditions, communication conditions and power quality indexes.

表 4.2 面板指示灯功能说明

Table 4.2 Function Description of LED Lamps

名称 Name	颜色 Color	指示灯含义 Meaning
运行指示 Run	绿 Green	装置运行时闪烁 Blink when this product is running
通讯状态 Communication	绿 Green	装置通讯时亮 Turn on during communication
暂态事件 Dip/Swell	红 Red	电压暂升、暂降、短时中断，电压电流瞬态 Voltage swell, dip, interruption and transient voltage/ current
频率偏差 Frequency deviation	红 Red	电网频率越限 Power frequency beyond the limit
电压偏差 Voltage deviation	红 Red	电压有效值越限、电压负序不平衡 Voltage RMS beyond the limit, Negative sequence voltage unbalance
闪变越限 Flicker	红 Red	电压闪变越限 Voltage flicker beyond the limit

谐波越限 Harmonic	红 Red	电压电流总谐波越限、各次谐波越限、电压奇次偶次谐波越限、 Total voltage/current harmonics beyond the limit, Each harmonic beyond the limit, Odd/ even voltage harmonics beyond the limit
装置异常 Unusual	红 Red	装置异常 Abnormal running

4.3 快速导航

4.3 Quick navigation

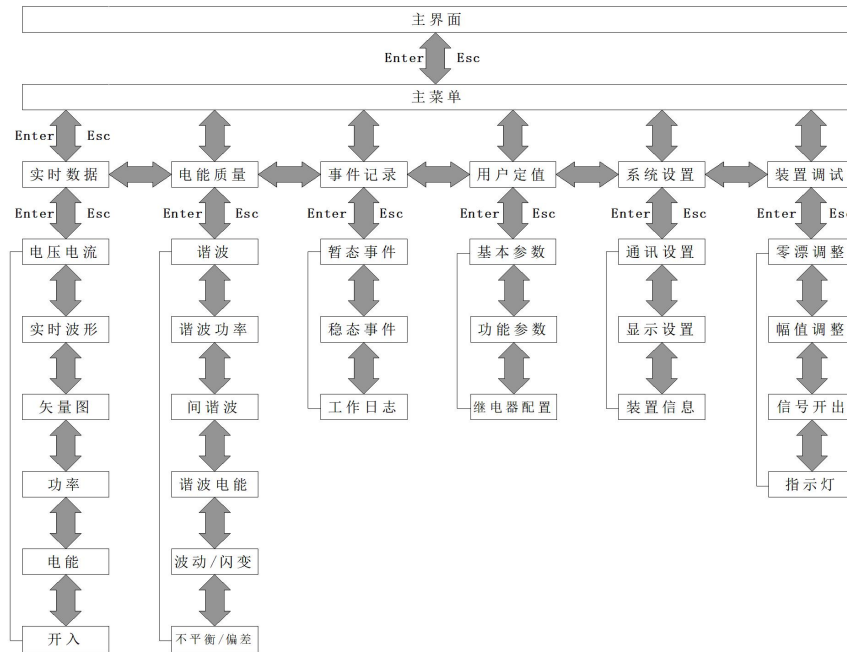


图4.2 快速导航示意图

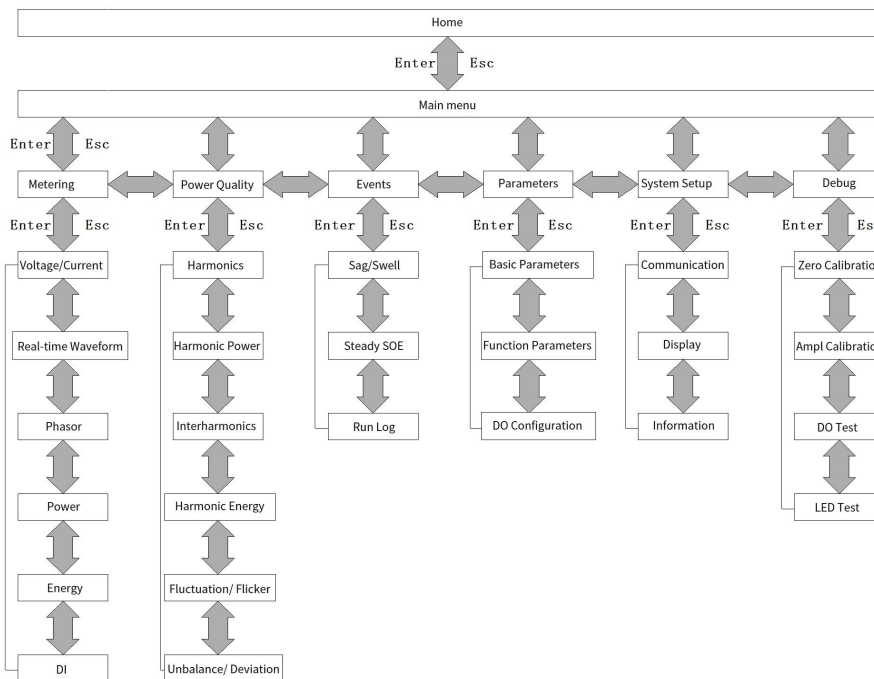


Fig. 4.2 Quick navigation

4.4 操作说明

4.4 Operation instructions

4.4.1 主界面

4.4.1 Home

装置上电后，自动进入主界面。主界面主要显示实时电压电流有效值及相位角、回路频率、暂态事件数、稳态事件数和时间。界面右侧事件计数为未查看事件数目，进入"事件记录"菜单查看后计数清零。

After it is powered on, this product opens Home automatically. Home mainly shows the real-time RMS voltage/ current and phase angles, channel frequency, number of dip/swell events, number of steady events and time. The number of events at the right side is the number of unviewed events, which can be cleared after entering the "Event" menu.

	有效值	相位角	THD	TIHD	暂态事件
UAB	10.00 kV	0.000 °	0.000%	0.000%	0
UBC	10.00 kV	240.00 °	0.000%	0.000%	
UCA	10.00 kV	120.00 °	0.000%	0.000%	稳态事件
U0	0.000 kV	0.000 °	0.000%	0.000%	0
IA	100.00 A	330.00 °	0.000%	0.000%	
IB	100.00 A	210.00 °	0.000%	0.000%	频率
IC	100.00 A	90.00 °	0.000%	0.000%	50.00Hz
I0	0.000 A	0.000 °	0.000%	0.000%	

2022-12-19 10:56:23

图 4.3 主界面

	RMS	Phase	THD	TIHD	Temporary
UAB	10.00 kV	0.000 °	0.000%	0.000%	0
UBC	10.00 kV	240.00 °	0.000%	0.000%	
UCA	10.00 kV	120.00 °	0.000%	0.000%	Steady
U0	0.000 kV	0.000 °	0.000%	0.000%	0
IA	100.00 A	330.00 °	0.000%	0.000%	
IB	100.00 A	210.00 °	0.000%	0.000%	Freq
IC	100.00 A	90.00 °	0.000%	0.000%	50.00 Hz
I0	0.000 A	0.000 °	0.000%	0.000%	

2022-12-19 10:56:23

Fig. 4.3 Home

4.4.2 主菜单

4.4.2 Main menu

主菜单设有"实时数据"、"电能质量"、"事件记录"、"用户定值"、"系统设置"、"装置调试"等 6 个子菜单，当选中某一子菜单时会有蓝色选择框出现并显示高亮，同时在右侧"菜单导航"栏显示该子菜单的下属菜单内容。此时，再按确认键即可进入该子菜单。

The main menu is divided into six submenus, namely "Metering", "Power quality", "Events", "Parameters", "System Setup" and "Debug". When a submenu is selected, a blue select box will appear and be highlighted, and the the selected submenu items will be displayed in the "Preview" on the right. Then, press "↵" to enter the submenu.



图 4.4 主菜单

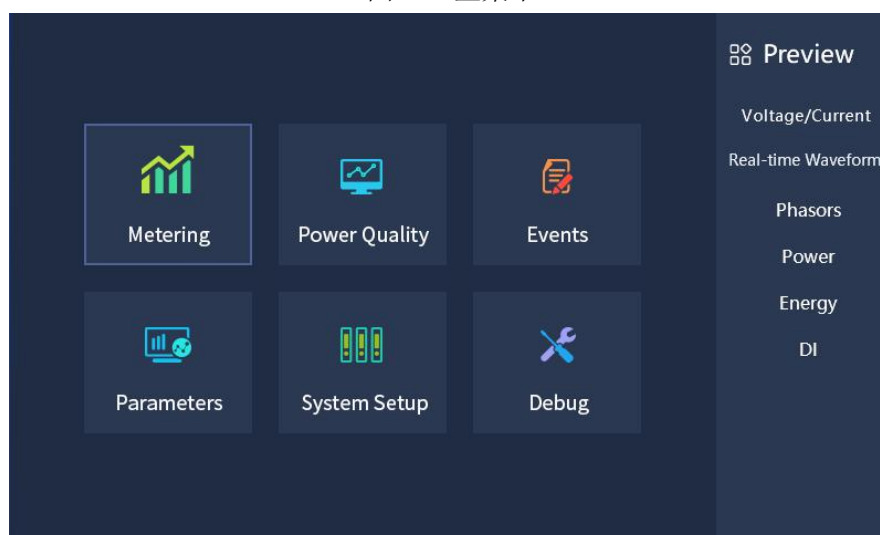


Fig. 4.4 Main Menu

4.4.3 实时数据

4.4.3 Metering

在主菜单选择"实时数据"菜单进入实时数据界面。实时数据菜单主要有"电压电流"、"实时波形"、"矢量图"、"功率计量"、"电能计量"、"开入状态"六个子菜单。

Select "Metering" on main menu and enter "Metering" submenu. Submenu "Metering" provides six screens, i.e. "Voltage/current", "Real-time waveform", "Phasors", "Power", "Energy" and "DI".



图4.5 实时数据



Fig. 4.5 Metering

4.4.3.1 实时数据-电压电流

4.3.3.1 Metering - Voltage/Current

电压电流界面用于显示最近3s内，电压电流的一次值、二次值及相位角。

Screen "Voltage/current" will show the primary and second values of voltage/current, as well as phase angles in last 3s.

(注1：本装置所有相位角均以A相电压基波相位角为基准)。

(Note 1. All phase angles of this product are based on the fundamental phase angle of the phase-A voltage.)

电压电流			
	一次值	二次值	相位角
UA	5.774kV	57.740V	0°
UB	5.774kV	57.740V	240°
UC	5.774kV	57.740V	120°
U0	0.000V	0.000	0°
IA	100.000A	5.000A	330°
IB	100.000A	5.000A	210°
IC	100.000A	5.000A	90°
I0	0.000A	0.000A	0°

图4.6 电压电流

Voltage/Current			
	Primary	Secondary	Phase
UA	5.774 kV	57.740 V	0 °
UB	5.774 kV	57.740 V	240 °
UC	5.774 kV	57.740 V	120 °
U0	0.000 V	0.000 V	0 °
IA	100.000 A	5.000 A	330 °
IB	100.000 A	5.000 A	210 °
IC	100.000 A	5.000 A	90 °
I0	0.000 A	0.000 A	0 °

Fig. 4.6 Voltage & current

4.4.3.2 实时数据-实时波形

4.4.3.2 Metering –Real-time waveform

实时波形界面主要显示当前采样值波形，按左右键选择操作区域；按上下键可以选择显示的通道，黄、绿、红分别为 A、B、C 三相，蓝色代表零序；按"+"、"-"键可以移动波形光标。

Screen "Real-time waveform" will mainly show the waveform of real-time sampling value. Press "+" or "-" to select a channel and "▲" or "▼" to select a channel. The selected one will turn white. Yellow, green and red indicate phase A, B and C respectively and blue indicates the zero sequence.

Press "◀" or "▶" to select the operation area; press "▲" or "▼" to select the displayed channel. Yellow, green and red indicate phase A, B and C respectively and blue indicates the zero sequence. Press "+" and "-" keys to move the waveform cursor.

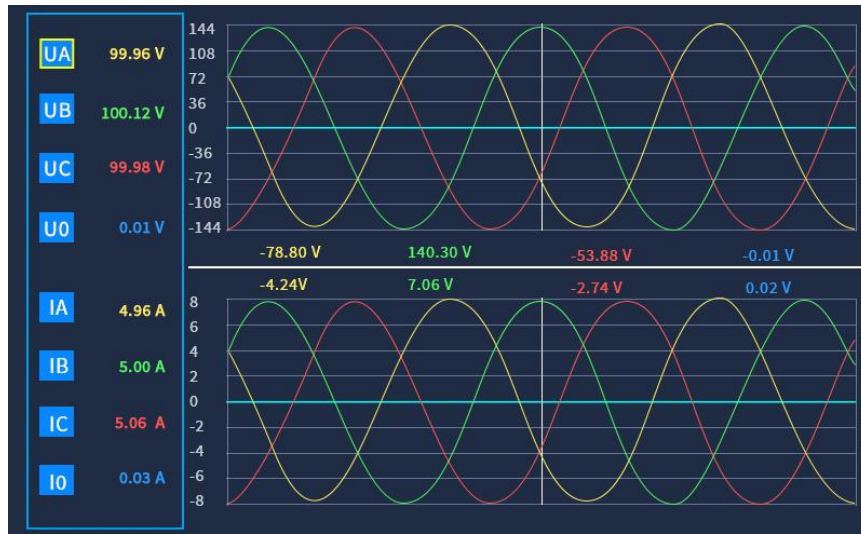


图4.7 实时波形

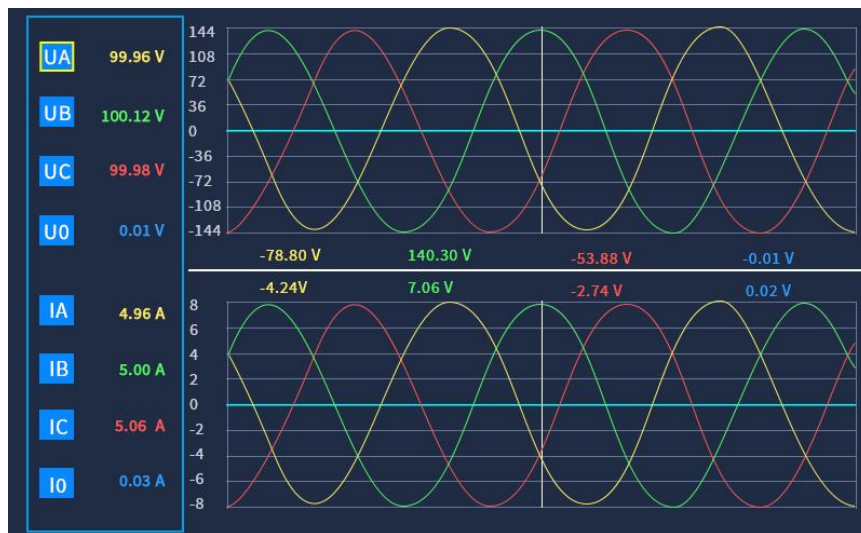


Fig. 4.7 Real-time Waveform

4.4.3.3 实时数据-矢量图

4.4.3.3 Metering – Phasors

矢量图界面显示当前回路的电压电流矢量图，并显示当前的负序/零序/正序电压电流值和负序/零序电压电流不平衡度。

Screen "Phasors" will show the vector diagram of the voltage and current, and negative/ zero/ positive sequence voltage and current as well as the negative/ zero sequence voltage/ current unbalance.

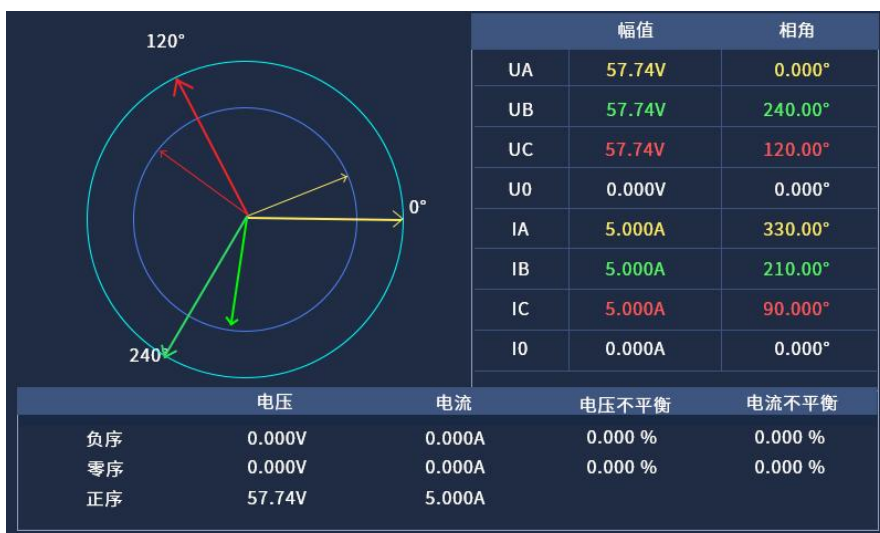


图4.8 矢量图

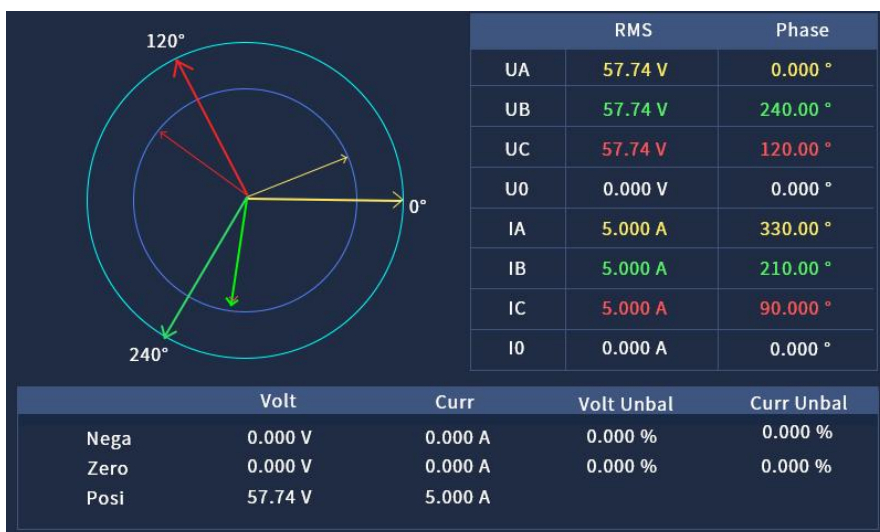


Fig. 4.8 Phasors

4.4.3.4 实时数据-功率计量

4.4.3.4 Metering – Power

功率界面显示有功功率、无功功率、功率因数、视在功率、基波有功功率数据。

Screen "Power" will show active/reactive power, power factor, apparent power, fundamental active power.

功率计量				
	A	B	C	合计
有功功率(kw)	0.000	0.000	0.000	0.000
无功功率(kVar)	0.000	0.000	0.000	0.000
功率因数	0.000	0.000	0.000	0.000
视在功率(kVA)	0.000	0.000	0.000	0.000
基波有功(kw)	0.000	0.000	0.000	0.000

图4.9 功率

Power				
	A	B	C	Total
P(kW)	0.000	0.000	0.000	0.000
Q(kVar)	0.000	0.000	0.000	0.000
PF	0.000	0.000	0.000	0.000
S(kVA)	0.000	0.000	0.000	0.000
Fundam P(kW)	0.000	0.000	0.000	0.000

Fig. 4.9 Power

4.4.3.5 实时数据-电能计量

4.4.3.5 Metering – Energy

功率界面显示正向有功"EP+"、正向无功"EQ+"、反向有功"EP-"、反向无功"EQ-"、视在电能"ES"等数据信息。

Screen "Energy" will show forward active energy EP+, forward reactive energy EQ+, reverse active energy EP-, reverse reactive energy EQ-, apparent energy ES and other related data.

电能计量				
	A	B	C	合计
EP+(kW·h)	0.001	0.001	0.001	0.003
EP-(kW·h)	0.000	0.000	0.000	0.000
EQ+(kW·h)	0.000	0.000	0.000	0.001
EQ-(kW·h)	-0.000	-0.000	-0.000	0.001
ES(kVar·h)	0.001	0.001	0.001	0.004

图4.10 电能

Energy				
	A	B	C	Total
EP+(kW·h)	0.001	0.001	0.001	0.003
EP-(kW·h)	0.000	0.000	0.000	0.000
EQ+(kW·h)	0.000	0.000	0.000	0.001
EQ-(kW·h)	-0.000	-0.000	-0.000	0.001
ES(kVar·h)	0.001	0.001	0.001	0.004

Fig. 4.10 Energy

4.4.3.6 实时数据-开入状态

4.4.3.6 Metering – DI

界面显示各开关量输入回路的状态，有输入显示为"合"，无输入时显示为"分"。

Screen "DI" will show the state of digital inputs. "CLOSE" indicates the existence of input while "OPEN" indicates lack of input.

开入状态

序号	DI	状态	
1	DI1	分	合
2	DI2	分	合
3	DI3	分	合
4	DI4	分	合
5	DI5	分	合
6	DI6	分	合

图 4.11 开入显示

DI

序号	DI	Ctrl	
1	DI1	OPEN	CLOSE
2	DI2	OPEN	CLOSE
3	DI3	OPEN	CLOSE
4	DI4	OPEN	CLOSE
5	DI5	OPEN	CLOSE
6	DI6	OPEN	CLOSE

Fig. 4.11 DI

4.4.4 电能质量

4.4.4 Power quality

在主菜单选择"电能质量"菜单进入电能质量界面。电能质量子菜单主要有"谐波测量"、"谐波功率"、"间谐波测量"、"谐波电能"、"波动/闪变"、"不平衡/偏差"六个子菜单。

Select "Power quality" on main menu and enter "Power quality" submenu. Submenu "Metering" provides six screens, i.e. "Harmonics", "Harmonic power", "Interharmonics", "Harmonic Energy", "Fluctuation/ Flicker" and "Unbalance/ Deviation".



图4.12 电能质量



Fig. 4.12 Power Quality

4.4.4.1 电能质量-谐波

4.4.4.1 Power Quality - Harmonics

进入"谐波"菜单后，由谐波柱状图、谐波表2个部分组成，谐波柱状图显示当前选择通道的谐波畸变率与谐波次数的柱状图。谐波表显示当前通道1~63次谐波的有效值、含有率、相角，可以使用左右键进行图表切换。在列表界面下，需要按"确认键"进入当前选中的通道，然后按上下键进行翻页，查看2~63次谐波数据信息。

Screen "Harmonics" will show the harmonics in two forms, chart and table. The chart describes the harmonic distortion and the order of harmonics of the selected channel graphically. The table lists the RMS, ratio and phase angle of the 1st to 63rd harmonics of the selected channel. To make a switch, press use left and right buttons to switch between the graph and the table, press "◀" or "▶". In the form of table, press "↵" to enter the selected channel, and press "▲" or "▼" to scroll through 1st to 63rd harmonic data.

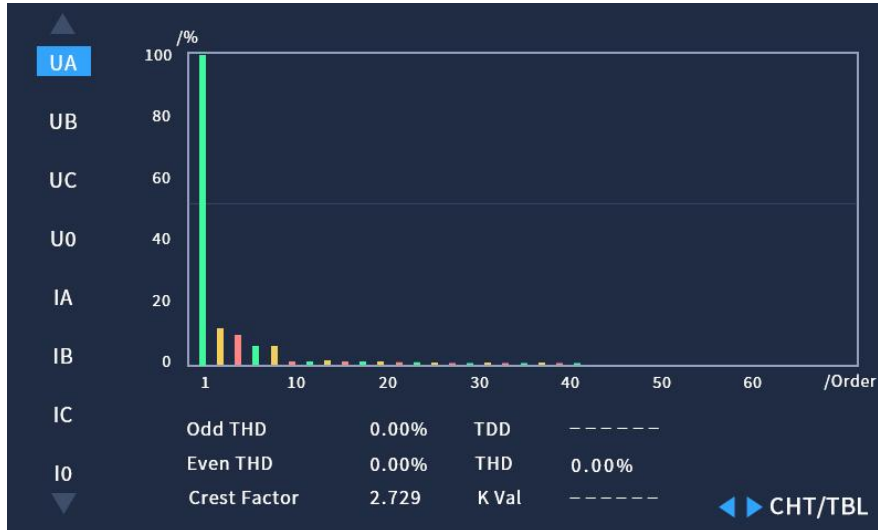


图 4.13 谐波柱状图

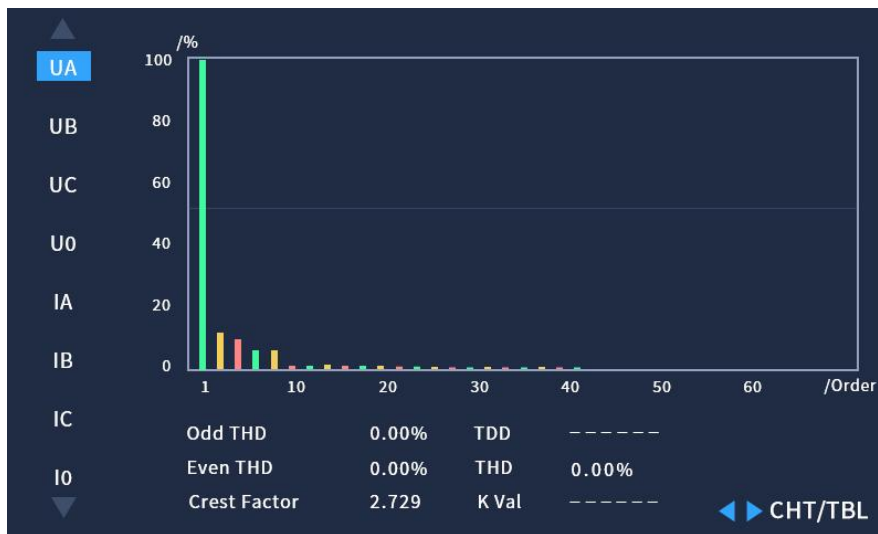


Fig. 4.13 Harmonics Chart

	次数	有效值 (V)	含有率 (%)	相角 (°)
UA	0	0.052	0.000	0.000
UB	1	0.000	0.000	0.000
UC	2	0.000	0.000	0.000
U0	3	0.000	0.000	0.000
IA	4	0.000	0.000	0.000
IB	5	0.000	0.000	0.000
IC	6	0.000	0.000	0.000
I0	7	0.000	0.000	0.000
	8	0.000	0.000	0.000
	9	0.000	0.000	0.000

按确认键进入翻页 图表切换

图 4.14 谐波表

	Order	RMS(V)	Ratio(%)	Phase(°)
UA	0	0.052	0.000	0.000
UB	1	0.000	0.000	0.000
UC	2	0.000	0.000	0.000
U0	3	0.000	0.000	0.000
IA	4	0.000	0.000	0.000
IB	5	0.000	0.000	0.000
IC	6	0.000	0.000	0.000
I0	7	0.000	0.000	0.000
	8	0.000	0.000	0.000
	9	0.000	0.000	0.000

Press ENTER to turn page CHT/TBL

Table 4.14 Harmonics Table

4.4.4.2 电能质量-谐波功率

4.4.4.2 Power Quality – Harmonic power

"谐波功率"菜单分别显示 A、B、C 三相的 1~63 次谐波功率值，包括谐波有功功率、谐波无功功率、谐波视在功率、谐波功率因数。每页显示 10 次谐波功率，按确认键可翻页查看 1~63 次谐波功率，按左右键可依次查看谐波有功功率、谐波无功功率、谐波视在功率、谐波功率因数。

Screen "Harmonic power" will show 1st to 63rd harmonic power of phases A, B and C. Such data includes the active harmonic power, the reactive harmonic power, the apparent harmonic power and the harmonic power factor. Each page lists 10 harmonic power values. Press "↵" to scroll through 1st to 63rd harmonics. To check the active harmonic power, the reactive harmonic power, the apparent harmonic power and the harmonic power factor, press "◀" or "▶".

阶次	A (kW)	B (kW)	C (kW)
1	61.704	43086	43086
2	0.000	0.0671	0.0661
3	0.000	0.0042	1.0042
4	-0.000	41.895	41.895
5	-0.082	0.0122	0.0122
6	-0.000	9.5645	10.716
7	-0.001	0.0059	0.0059
8	-0.000	0.0003	0.0042
9	-0.001	0.7740	0.3788
10	-0.000	0.0024	0.0014

图 4.15 谐波功率

Order	A (kW)	B (kW)	C (kW)
1	61.704	43086	43086
2	0.000	0.0671	0.0661
3	0.000	0.0042	1.0042
4	-0.000	41.895	41.895
5	-0.082	0.0122	0.0122
6	-0.000	9.5645	10.716
7	-0.001	0.0059	0.0059
8	-0.000	0.0003	0.0042
9	-0.001	0.7740	0.3788
10	-0.000	0.0024	0.0014

Fig. 4.15 Harmonic Power

4.4.4.3 电能质量-间谐波

4.4.4.3 Power Quality – Interharmonics

"间谐波"菜单显示0.5~62.5次间谐波有效值及含有率。需要按"确认键"进入当前选中的通道，然后按上下键进行翻页，查看0.5~62.5次间谐波数据信息。

Screen "Interharmonics" will show the RMS and ratios of 0.5th to 62.5th Interharmonics. Press "↵" to enter the selected channel, and press "▲" or "▼" to scroll through 0.5th to 62.5th Interharmonics data.

	阶次	有效值 (V)	含有率 (%)
UA	0.5	0.000	0.000
UB	1.5	0.000	0.000
UC	2.5	0.000	0.000
U0	3.5	0.000	0.000
U0	4.5	0.000	0.000
IA	5.5	0.000	0.000
IB	6.5	0.000	0.000
IC	7.5	0.000	0.000
IC	8.5	0.000	0.000
I0	9.5	0.000	0.000

按确认键进入翻页

图 4.16 间谐波

	Order	RMS(V)	Ratio(%)
UA	0.5	0.000	0.000
UB	1.5	0.000	0.000
UC	2.5	0.000	0.000
U0	3.5	0.000	0.000
U0	4.5	0.000	0.000
IA	5.5	0.000	0.000
IB	6.5	0.000	0.000
IC	7.5	0.000	0.000
IC	8.5	0.000	0.000
I0	9.5	0.000	0.000

Press ENTER to turn page

Fig. 4.16 Interharmonics

4.4.4.4 电能质量-谐波电能

4.4.4.4 Power Quality – Harmonic Energy

"谐波电能"菜单显示 1 ~ 63 次谐波电能值，按左右键切换视在电能 ES、有功电能 EP、无功电能 EQ、正向有功电能 P+、反向有功电能 P-、正向无功电能 Q+、反向无功电能 Q-、第一象限无功电能 Q1、第二象限无功电能 Q2、第三象限无功电能 Q3、第四象限无功电能 Q4。每页显示 10 次，按"确认键"进入翻页查看 1~ 63 次。

Screen "Harmonic Energy" will show 1st to 63rd harmonic energy. To check the apparent energy ES, the active energy EP, the reactive energy EQ, the forward active energy P+, the reverse active energy P-, the forward reactive energy Q+, the reverse reactive energy Q-, the reactive energy of the 1st quadrant Q1, the reactive energy of the 2nd quadrant Q2, the reactive energy of the 3rd quadrant Q3 and the reactive energy of the 4th quadrant Q4, press "◀" or "▶". Each page lists 10 harmonics data. Press "↵" to scroll through 1st to 63rd harmonics.

阶次	A (kVA·h)	B (kVA·h)	C (kVA·h)
1	43086	43086	43086
2	0.0456	0.0671	0.0661
3	0.0042	0.0042	1.0042
4	41.895	41.895	41.895
5	0.0122	0.0122	0.0122
6	9.5645	9.5645	10.716
7	0.0059	0.0059	0.0059
8	0.0003	0.0003	0.0042
9	0.7400	0.7740	0.3788
10	0.0020	0.0024	0.0014

▲▼ 认键进入翻页 ▶ ES EP EQ EP+

图 4.17 谐波电能

Order	A (kVA·h)	B (kVA·h)	C (kVA·h)
1	43086	43086	43086
2	0.0456	0.0671	0.0661
3	0.0042	0.0042	1.0042
4	41.895	41.895	41.895
5	0.0122	0.0122	0.0122
6	9.5645	9.5645	10.716
7	0.0059	0.0059	0.0059
8	0.0003	0.0003	0.0042
9	0.7400	0.7740	0.3788
10	0.0020	0.0024	0.0014

▲▼ 认键进入翻页 ▶ ES EP EQ EP+

Fig. 4.17 Harmonic Energy

4.4.4.5 电能质量-波动/闪变

4.4.4.5 Power Quality – Fluctuation/ Flicker

"波动/闪变"菜单显示三相电压的电压波动与电压闪变值。

Screen "Fluctuation/ Flicker" will show the voltage fluctuation and the voltage flicker of three phases.

电压波动			电压闪变	
	频度 (次/min)	波动值 (%)	短闪变(10m)	长闪变(2h)
UA	0.000	0.000	0.000	0.000
UB	0.000	0.000	0.000	0.000
UC	0.000	0.000	0.000	0.000
U0	---	---	---	---

图 4.18 波动/闪变

Fluctuation			Flicker	
	Rate (cnt/min)	Value (%s)	Pst(10m)	Plt(2h)
UA	0.000	0.000	0.000	0.000
UB	0.000	0.000	0.000	0.000
UC	0.000	0.000	0.000	0.000
U0	---	---	---	---

Fig. 4.18 Fluctuation/ Flicker

4.4.4.6 电能质量-不平衡/偏差

4.4.4.6 Power Quality – Unbalance/ Deviation

"不平衡/偏差"。菜单显示 A、B、C 三相电压上偏差/电压下偏差、频率偏差、正序/负序/零序电压幅值、正序/负序/零序电流幅值、负序/零序电压不平衡度、负序/零序电流不平衡度。

Screen "Unbalance/Deviation" will show maximum/minimum voltage deviation, frequency deviation, positive/negative/zero sequence voltage amplitude, positive/negative/zero sequence current amplitude, negative/zero sequence voltage unbalance and negative/zero sequence current unbalance of phases A, B and C.

序分量	幅值	不平衡度
I1	0.000 A	---
I2	0.000 A	0.000
I0	0.000 A	0.000
U1	0.000 V	---
U2	0.000 V	0.000
U0	0.000 V	0.000
上偏差 (%)		下偏差 (%)
UA	-99.984	99.984
UB	-99.972	99.972
UC	-99.977	99.976
频率: 50.000 Hz		频率偏差: 50.000 Hz

图 4.19 不平衡/偏差

Sequence	Amplitude	Unbalance
I1	0.000 A	---
I2	0.000 A	0.000
I0	0.000 A	0.000
U1	0.000 V	---
U2	0.000 V	0.000
U0	0.000 V	0.000
Over-Deviation (%)		Under-Deviation (%)
UA	-99.984	99.984
UB	-99.972	99.972
UC	-99.977	99.976
Freq: 50.000 Hz		Freq Deviation: 50.000 Hz

Fig. 4.19 Unbalance/ Deviation

4.4.5 事件记录

4.4.5 Events

在主菜单选择"事件记录"菜单进入事件记录界面。"事件记录"菜单有"暂态事件"、"稳态事件"、"工作日记"三个子菜单。

Select "Events" on main menu and enter "Events" submenu. Submenu "Events" provides three screens, i.e. "Dip/Swell", "Steady Events" and "System Log".



图 4.20 事件记录



Fig. 4.20 Events

4.4.5.1 电能质量-暂态事件

4.4.5.1 Power Quality – Dip/Swell

"暂态事件"菜单显示包含电压暂升、电压暂降、电压短时中断、冲击电流等暂态事件和电压瞬态/电流瞬态两类瞬态事件。

Screen "Dip/Swell" will show temporary event types, i.e. voltage swell, voltage dip, voltage interruption, and inrush current and two transient event types, i.e. transient voltage and transient current.

暂态事件			事件总数: 34
序号	事件时间	事件信息	
11	2023-06-14 15:41:48	暂升定位:线路侧	
12	2023-06-14 15:41:48	暂升定位:母线侧	
13	2023-06-14 15:41:48	电压暂升	
14	2023-06-14 15:41:27	暂降定位:母线侧	
15	2023-06-14 15:41:27	电压短时中断	
16	2023-06-14 15:41:27	暂降定位:母线侧	
17	2023-06-14 15:41:27	暂降定位:母线侧	
18	2023-06-14 15:41:12	暂降定位:母线侧	
19	2023-06-14 15:41:12	电压暂降	
20	2023-06-14 15:41:12	暂降定位:母线侧	

▼ 页数2/4

图 4.21 暂态事件

Temporary-state			Event number: 34
No.	Timestamp	Event Details	
11	2023-06-14 15:41:48	U swell location:Outgoing side	
12	2023-06-14 15:41:48	U swell location:Incoming side	
13	2023-06-14 15:41:48	Voltage swell	
14	2023-06-14 15:41:27	U dip location:Incoming side	
15	2023-06-14 15:41:27	Voltage interruption	
16	2023-06-14 15:41:27	U dip location:Incoming side	
17	2023-06-14 15:41:27	U dip location:Incoming side	
18	2023-06-14 15:41:12	U dip location:Incoming side	
19	2023-06-14 15:41:12	Voltage dip	
20	2023-06-14 15:41:12	U dip location:Incoming side	

▼ 2/4

Fig. 4.21 Dip/Swell

按上下键选择发生的事件，按“↵”确认键可查看事件详细参数。

如图 4.22 (a) 所示为电压暂降事件记录，在该界面下按“↵”确认键可查看该事件记录的波形，如图 4.22 (b) 所示为电压暂降对应的事件记录波形。

Press "▲" or "▼" to select an event and press "↵" to check the event details.

As shown in Fig. 4.22(a), the voltage dip event is recorded, and the waveform of the event can be viewed by pressing the "↵" as shown in Fig. 4.22(b). As shown in Fig. 4.23(a), the voltage swell event is recorded, and the waveform of the event can be viewed by pressing the "↵" as shown in Fig. 4.23(b).



图 4.22(a) 电压暂降事件

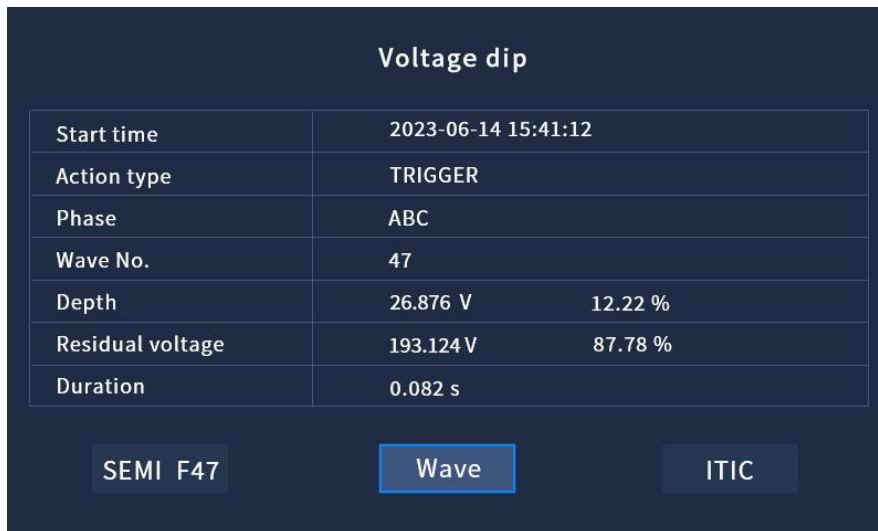


Fig. 4.22(a) Voltage dip

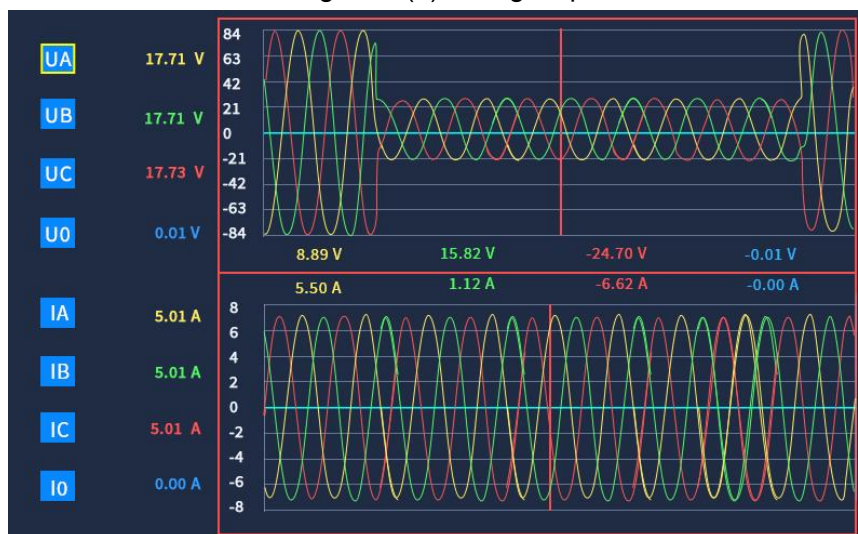


图 4.22(b) 电压暂降波形

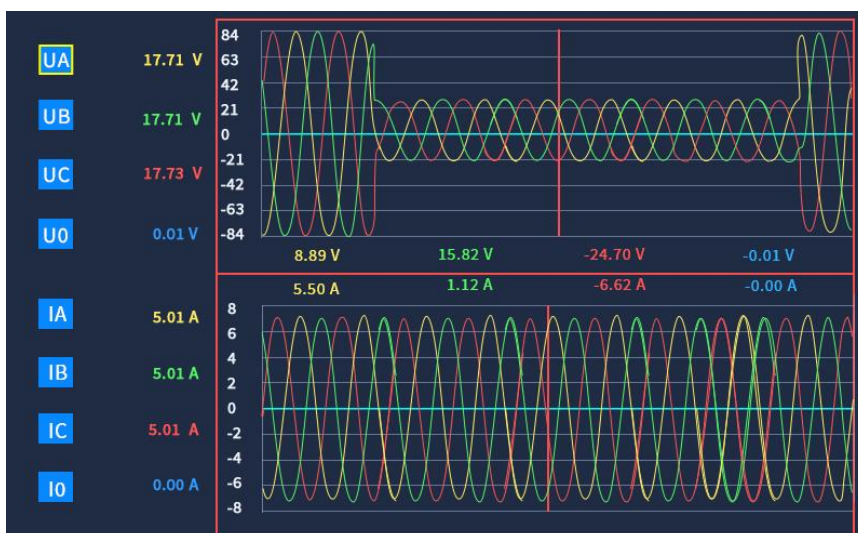


Fig. 4.22(b) Voltage dip waveform

如图 4.23 (a) 所示为电压暂升事件记录, 在该界面下按 “↵” 确认键可查看该事件记录的波形, 如图 4.23 (b) 所示为电压暂升对应的事件记录波形。

电压暂升

开始时间	2023-06-14 15:41:48
动作类型	触发
相位	ABC
录波编号	49
最大值	112.258 V
持续时间	0.080 s

[波形](#)

图 4.23(a) 电压暂升事件

Voltage swell

Start time	2023-06-14 15:41:48
Action type	TRIGGER
Phase	ABC
Wave No.	49
Maximum voltage magnitude	112.258 V
Duration	0.080 s

[Wave](#)

Fig. 4.23(a) Voltage swell

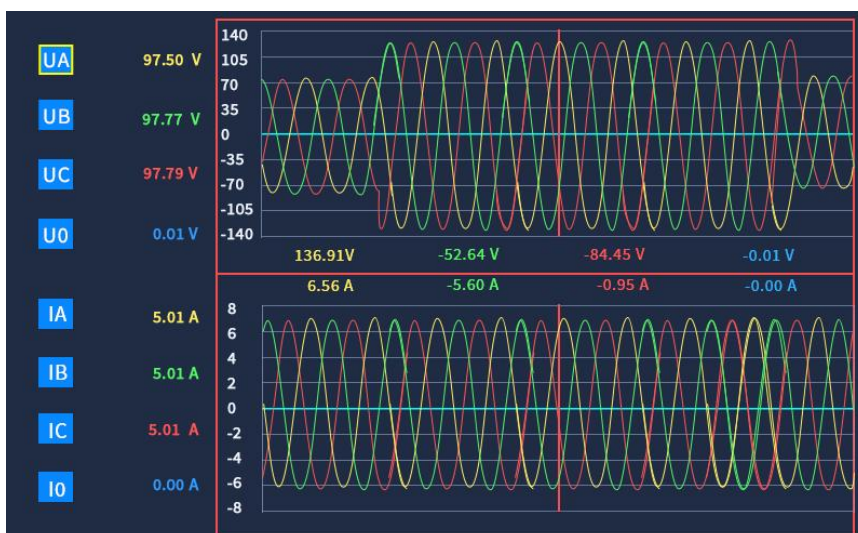


图 4.23(b) 电压暂升波形

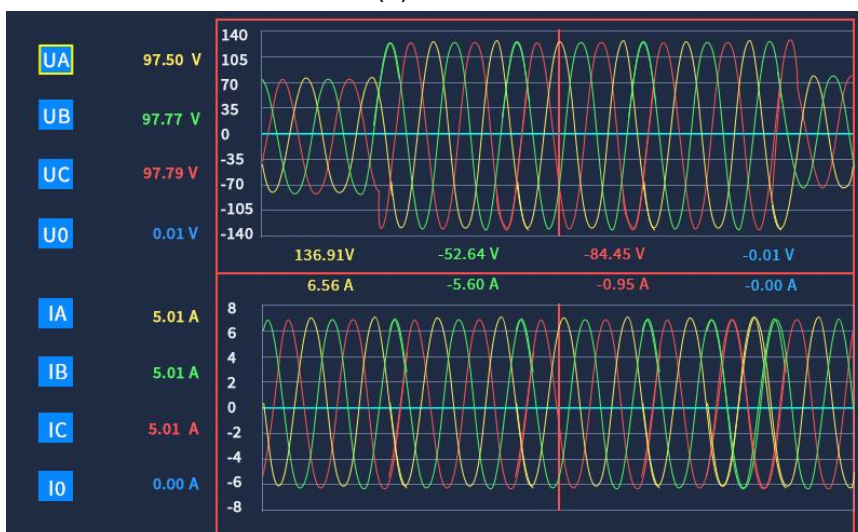


Fig. 4.23(b) Voltage swell waveform

4.4.5.1.1 暂态事件-暂降/暂升源定位

4.4.5.1.1 Dip/Swell-Dip location

暂降/暂升源定位功能可用于界定电压暂降/暂升事故中供用电双方各自的责任归属,以及指导排除暂降/暂升扰动源,该功能对协调电压暂降/暂升引起的供用电双方纠纷具有关键性作用,同时有助于制定电能质量治理方案以解决相关电能质量问题。图4.24为供电系统配置方案,在各分界点进线及重要回路出线处配置APView电能质量监测装置,实现暂降源定位功能。

The dip/swell location function can help to troubleshoot the location of voltage dip/swell and formulate a power quality governance plan to solve the related power quality problems. Figure 4.24 shows the configuration scheme of the power supply system, and the APView power quality monitoring device is configured at the incoming line of each demarcation point and the outgoing line of the important loop to realize the function of positioning the source of voltage dip.

装置可通过调用事故发生以及结束期间的波形、电参量等数据，利用等效阻抗法对阻抗突变位置进行判别分析，以确定暂降/暂升源位于线路侧或母线侧。如图4.25 (a) - (b)，分别为记录的电压暂降/暂升定位界面。

The device can use the equivalent impedance method to discriminate the position of impedance mutation by the waveform, measurement and other data during the accident, and determine that the voltage dip/swell source is located on the incoming side or outgoing side. As shown in Figure 4.25(a)-(b), the voltage dip/swell positioning interface are recorded, respectively.

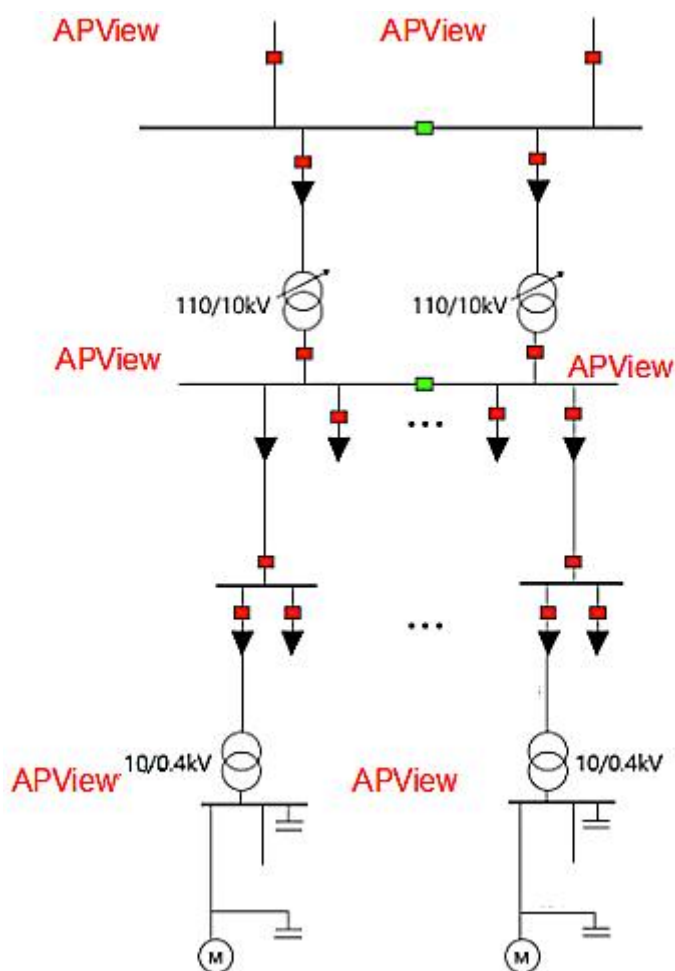


图 4.24 110kV 供电系统 APView 配置图

Fig. 4.24 APView configuration



图 4.25(a) 电压暂降源定位-母线侧

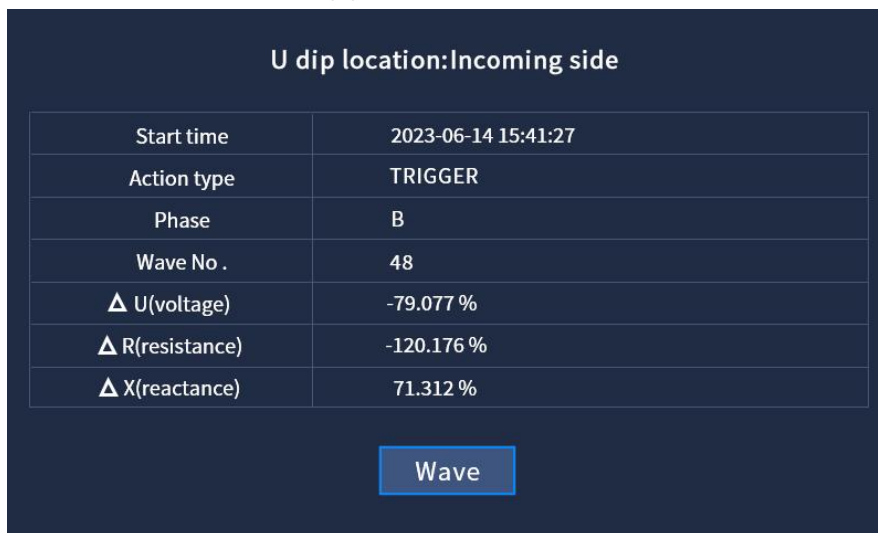


Fig. 4.25(a) Voltage dip location:incoming side



图 4.25(b) 电压暂升源定位-线路侧

U swell location:Outgoing side	
Start time	2023-06-14 15:41:48
Action type	TRIGGER
Phase	A
Wave No .	49
ΔU (voltage)	12.207 %
ΔR (resistance)	12.268 %
ΔX (reactance)	107.494 %

Wave

Fig. 4.25(b) Voltage swell location:Outgoing side

4.4.5.1.2 暂态事件-容忍度曲线分析

4.4.5.1.2 Dip/Swell-ITIC and SEMI F47 Curves

装置具有ITIC和SEMI F47曲线对电能质量暂态变化进行容忍度分析，ITIC曲线和SEMI F47曲线可在装置液晶界面上可查看。ITIC曲线主要是针对电压暂升、暂降、短时中断分析，适用于IT等行业；SEMI F47曲线主要是针对电压暂降、短时中断分析，适用于半导体等行业。如图4.26（a）、4.26（b）所示分别为电压暂降对应的ITIC和SEMI F47曲线。

The device has ITIC and SEMI F47 curves for tolerance analysis of power quality temporary changes, and ITIC curves and SEMI F47 curves can be viewed on the LCD interface of the device. ITIC curve is mainly for voltage dip,swell and interruption analysis, suitable for IT and other industries; The SEMI F47 curve is mainly for voltage dip and interruption analysis, and is suitable for semiconductor and other industries. Figure 4.26(a) and 4.26(b) show the ITIC and SEMI F47 curves corresponding to voltage dip respectively.

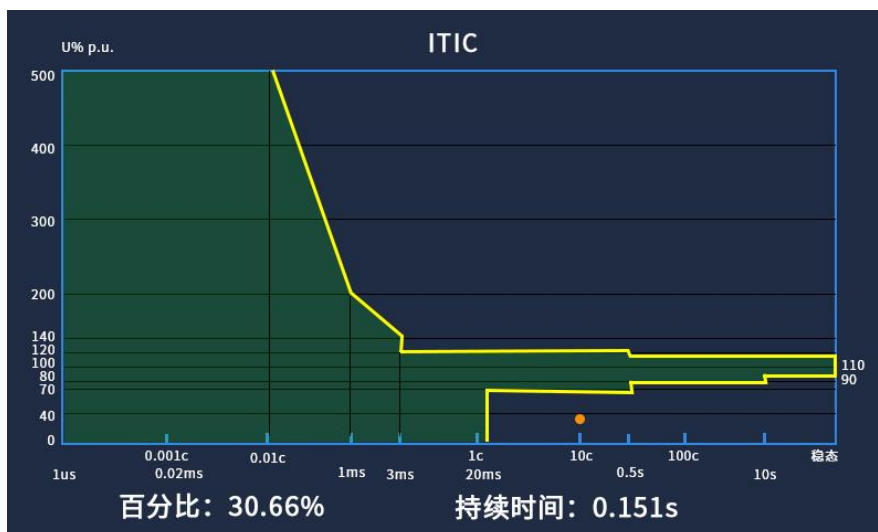


图 4.26(a) ITIC 容忍度曲线

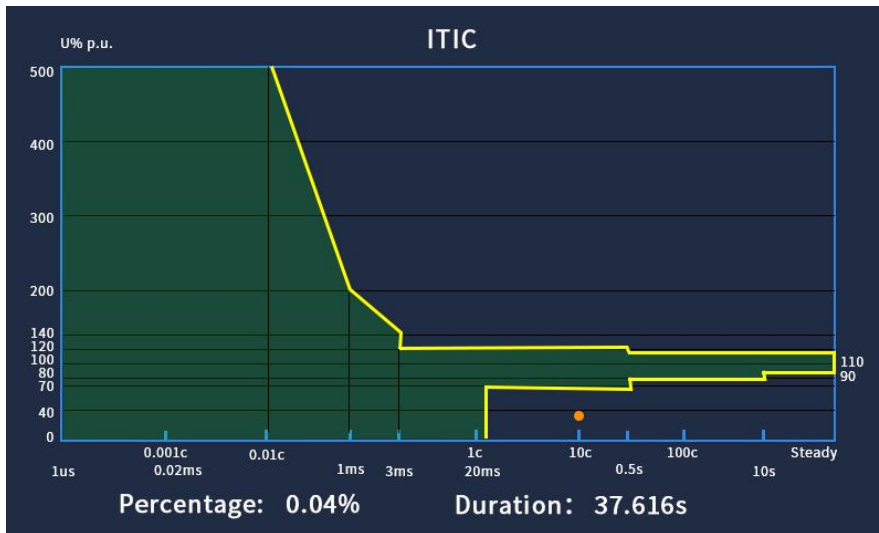


Fig. 4.26(a) ITIC Curves

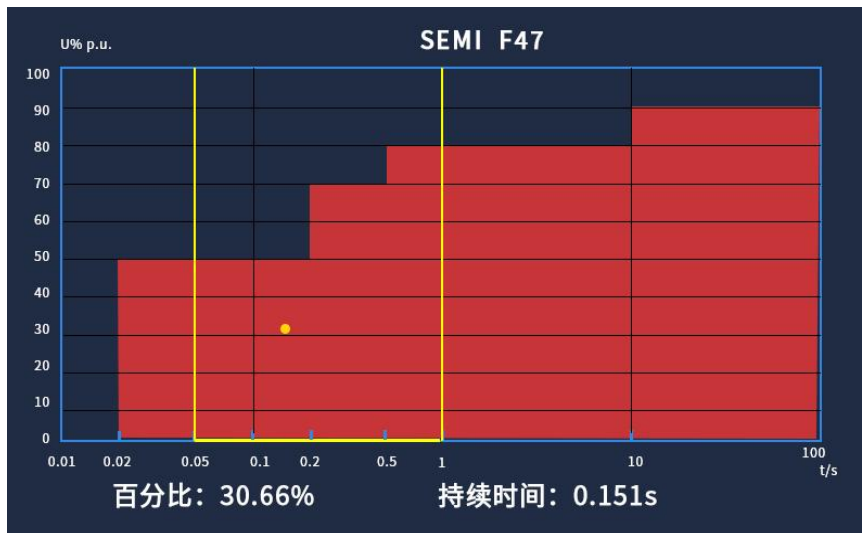


图 4.26(b) SEMI F47 容忍度曲线

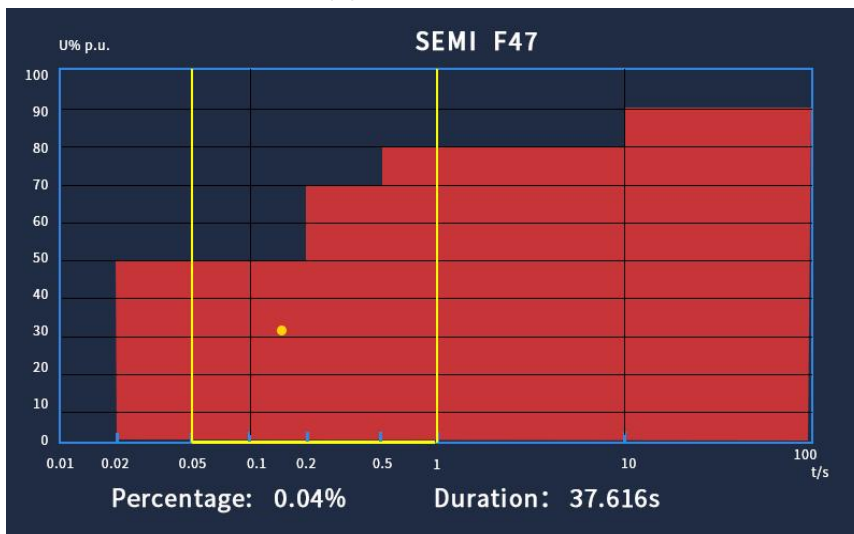


Fig. 4.26(b) SEMI F47 Curves

4.4.5.2 电能质量-稳态事件

4.4.5.2 Power Quality – Steady Events

稳态事件包含电压偏差、频率偏差、电压波动与闪变、谐波/间谐波、不平衡等稳态监测事件。其查看方法与4.4.5.1一致，如图4.26所示。

Screen "Steady Events" will show steady events such as voltage deviation, frequency deviation, voltage fluctuation and flicker, harmonics/ Interharmonics and unbalance. To check these data shown in Fig. 4.27, follow the steps as described in 4.4.5.1.

稳态事件			事件总数: 298
序号	事件时间	事件信息	
11	2023-06-14 15:41:48	电压3次谐波含有率超限	
12	2023-06-14 15:41:48	电压3次谐波含有率超限	
13	2023-06-14 15:41:48	电压总畸变率超限	
14	2023-06-14 15:41:27	电压总畸变率超限	
15	2023-06-14 15:41:27	电压负序不平衡度超限	
16	2023-06-14 15:41:27	电压负偏差超限	
17	2023-06-14 15:41:27	电压负偏差超限	
18	2023-06-14 15:41:12	电压负偏差超限	
19	2023-06-14 15:41:12	电压负偏差超限	
20	2023-06-14 15:41:12	电压负偏差超限	

▼ 页数2/30

图 4.27 稳态事件

Steady-state			Event number: 298
No.	Timestamp	Event Details	
11	2023-06-14 15:41:48	U 3rd harmonic ratio	
12	2023-06-14 15:41:48	U 3rd harmonic ratio	
13	2023-06-14 15:41:48	U total harmonic distortion	
14	2023-06-14 15:41:27	U total harmonic distortion	
15	2023-06-14 15:41:27	U2 unbalance ratio	
16	2023-06-14 15:41:27	Voltage under-deviation	
17	2023-06-14 15:41:27	Voltage under-deviation	
18	2023-06-14 15:41:12	Voltage under-deviation	
19	2023-06-14 15:41:12	Voltage under-deviation	
20	2023-06-14 15:41:12	Voltage under-deviation	

▼ 2/30

Fig. 4.27 Steady Events

按上下键选择发生的事件，按“↵”确认键可查看事件详细参数如图4.27所示，在该界面下按“↵”确认键可查看该事件记录的波形。

Press "▲" or "▼" to select an event and press "↵" to check the event details as shown in Fig. 4.28. Users can view the waveform recorded for the selected event with "↵".

电压负偏差超限	
开始时间	2023-06-14 15:41:27
动作类型	结束
相位	C
录波编号	8
触发值	0.017 %
持续时间	416.193 s
最小值	16.378 %

[波形](#)

图 4.28 电压负偏差超限

Voltage under-deviation	
Start time	2023-06-14 15:41:27
Action type	END
Phase	C
Wave No.	8
Trigger Value	0.017 %
Duration	416.193 s
Minimum Value	16.378 %

[Wave](#)

Fig. 4.28 Voltage under-deviation

4.4.5.3 电能质量-工作日志

4.4.5.3 Power Quality - System Log

“工作日志”菜单显示装置的参数、用户定值修改、系统参数修改和装置运行中出现的异常信息。

Screen "System Log" will show the product parameters, modification of parameters, modification of system parameters and abnormal running.

工作日记		事件总数: 186
	事件时间	事件信息
1	2021-12-14 08:54:20	定值组1被网页修改
2	2021-12-13 15:21:30	定值组3设置为默认配置
3	2021-12-13 14:26:26	定值组2设置为默认配置
4	2021-12-13 13:54:37	定值组1设置为默认配置
5	2021-12-13 12:47:52	定值组1被液晶修改
6	2021-12-13 10:32:23	定值组1被液晶修改
7	2021-12-12 09:56:19	定值组1被液晶修改
8	2021-12-12 08:22:26	定值组1被液晶修改
9	2021-12-09 15:47:29	定值组1被液晶修改
10	2021-12-09 15:46:43	定值组1被液晶修改

▲▼ 页数1/19

图 4.29 工作日记

System Log		Event number: 11689
No.	Timestamp	Event Details
1	2023-10-31 08:28:53	System startup
2	2023-10-30 16:22:00	System startup
3	2023-10-30 16:21:22	WEB reboot
4	2023-10-30 16:19:10	System startup
5	2023-10-30 16:18:32	Upgrade reboot
6	2023-10-30 16:17:36	Channel 1 user set modified by MMI
7	2023-10-30 16:17:28	Channel 1 user set modified by MMI
8	2023-10-30 16:13:38	Channel 1 user set modified by MMI
9	2023-10-30 16:13:33	Channel 1 user set modified by MMI
10	2023-10-27 16:00:26	Channel 1 user set modified by MMI

▶ Page 1/1169

Fig. 4.29 System Log

4.4.6 用户定值

4.4.6 Parameters

用户定值菜单设置密码为"0008"。

Screen "Parameters" is encrypted with a password (0008).

在主菜单选择"用户定值"进入用户定值设置界面。"用户定值"菜单包括"基本参数"、"功能参数"和"继电器配置"三个子菜单。

Select "Parameters" on main menu and enter "Parameters" submenu. "Parameters" provides three screens, i.e. "Basic Parameters", "Function Parameters" and "DO Configuration".



图4.30 用户定值界面

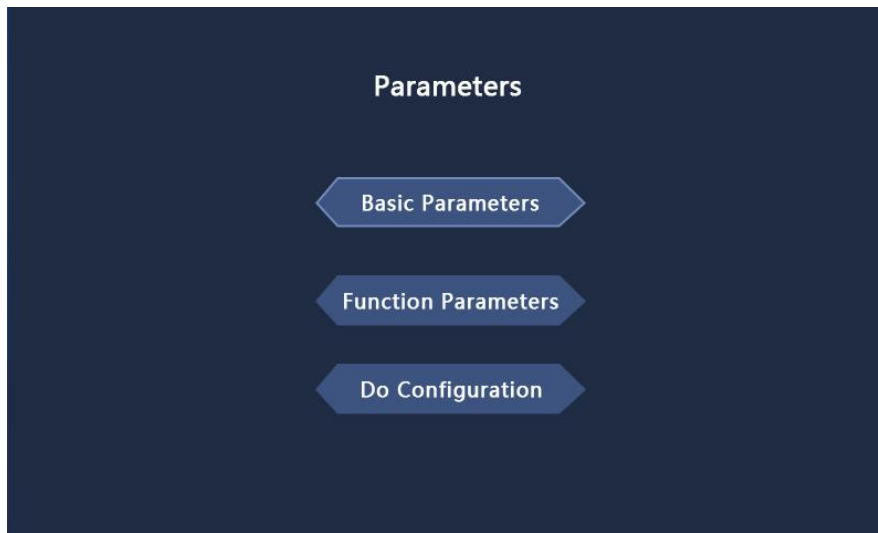


Fig. 4.30 Parameters

4.4.6.1 用户定值-基本参数

4.4.6.1 Parameters – Basic Parameters

"基本参数"界面可供用户根据装置使用的配电系统进行参数设置，包括"接线方式"、"标称电流"、"标称电压"等数据。

Screen "Basic Parameters" is used by users to set parameters according to the power distribution system for this product. It will show some data such as "Wiring mode", "Nominal current" and "Nominal voltage".

该位置参数需用户根据实际情况设置，

Users shall set the parameter according to actual conditions.

"接线方式"：Y 型为 3PT 接线， Δ 型为 2PT 接线；

"Wiring mode": Method STAR indicates 3PT wires and method DELTA indicates 2PT wires.

"标称电流"：二次额定电流，可设置为 5A 或 1A；

"Nominal current": As the secondary rated current, it may be 5A or 1A.

"标称电压": 二次额定电压, 可设置为 380V 或 220V 或 100V 或 57.74V, 此参数与电压暂升、暂降、电压偏差等功能相关。

"Nominal voltage": As the secondary rated voltage, it may be 380V, 220V, 100V or 57.74V, and related to voltage swell, voltage dip, voltage deviation and other functions.

"电压等级": 装置使用的一次系统电压等级, 可设置 0.38kV、6kV、10kV、20kV、35kV、66kV 等。

"Voltage class": It indicates the voltage class of the primary system to this product and may be 0.38kV, 6kV, 10kV, 20kV, 35kV, 66kV or other setting.

"用户协议容量"、"最小短路容量"、"供电设备容量": 根据实际情况填写, 如对该参数不明, 可保持默认值。

"User agreement capacity", "Min short-circuit capacity" and "Device supply capacity": Input the parameter according to actual conditions. If any value is unknown, follow defaults.

"PT 变比"、"CT 变比": 电压/电流互感器变比, 如电流互感器为 150/5, 那么 CT 变比为 30。

"PT ratio" and "CT ratio": They indicate the voltage transformation ratio and the current transformation ratio respectively. For example, CT transformation ratio is 30 for 150/5 current transformer.

"开入录波": 选择对应开入触发录波。

"DI trigger waveform record": Select the corresponding digital input to trigger recording waveform.

"定时录波开始时间": 预约录波的开启时间, 一旦到达此时间装置开始录波, 录波时长和**"事件录波前周期数"、"事件录波后周期数"**一致; 若需要多次定时录波, 则根据**"定时录波时间间隔"**再次触发录波, 直到**"定时录波次数"**结束。

"Timing waveform rcd start time": It is used to set the time when the recording function is activated. **"Waveform cnt before event"** must be the same as **"Waveform cnt after event"**. If the timed recording must be repeated, re-activate the recording function according to **"Timing waveform rcd time span"** until it reach the number of the **"Timing waveform rcd cnt"**.

默认配置"事件录波前周期数"为 10, "事件录波后周期数"为 10, 即

"Waveform cnt before event" and "Waveform cnt after event" are 10 respectively by default. In details,

1) 暂态事件最多录制 40 个周波:

Max. 40 cycles for dip/swell event recording

故障开始时刻前 10 个录波, 故障开始时刻后 10 个周波;

Record 10 cycles before start of faults and 10 cycles after start of faults;

故障返回时刻前 10 个周波, 故障返回时刻后 10 个周波。

Record 10 cycles before reset of faults and 10 cycles after reset of faults

2) 稳态事件 20 个周波:

20 cycles for steady event recording

事件动作, 故障开始时刻 10 个周波, 故障开始时刻后 10 个周波;

Event activated: record 10 cycles before start of faults and 10 cycles after start of faults;

事件返回, 故障返回时刻前 10 个周波, 故障返回时刻后 10 个周波。

Event reset: record 10 cycles before reset of faults and 10 cycles after reset of faults

若修改录波周期数, 举例: "事件录波前周期数"**15**, "事件录波后周期数"**6**, 则

Example: "Waveform cnt before event" is 15. "Waveform cnt after event" is 6.

1) 暂态事件最多录制 40 个周波。

Max. 40 cycles for temporary event recording

故障开始时刻前 15 个录波, 故障开始时刻后 5 个周波;

Record 15 cycles before start of faults and 5 cycles after start of faults;

故障返回时刻前 14 个周波, 故障返回时刻后 6 个周波。

Record 14 cycles before reset of faults and 6 cycles after reset of faults

2) 稳态事件 20 个周波。

20 cycles for steady event recording

告警动作, 故障开始时刻 15 个周波, 故障开始时刻后 5 个周波;

Alarm activated: record 15 cycles before start of faults and 5 cycles after start of faults;

告警返回, 故障返回时刻前 14 个周波, 故障返回时刻后 6 个周波。

Alarm reset: record 14 cycles before reset of faults and 6 cycles after reset of faults

按"确认键"进入数据修改，按上下键修改参数。当参数设置完毕后，按"返回键"会提醒修改数据是否保存，如需保存，需输入密码"0008"，会提示保存成功；密码输入错误，则提示是否重新输入。

Press "↵" to modify data and "▲" or "▼" to change parameters. When "Esc" is pressed after the parameter setting, a prompt message will be shown, asking "save or not". To save the modification, input the password (0008). Then a prompt message will indicate that modification is saved successfully. If a wrong password is input, a prompt message will be shown, asking "Whether to re-enter".

序号	基本参数	
1	接线方式	Y型
2	标称电流	5.000 A
3	标称电压	57.740 V
4	电压等级	10.000 kv
5	用户协议容量	10.000 MVA
6	最小短路容量	10.000 MVA
7	供电设备容量	10.000 MVA
8	PT变化	1.000
9	CT变化	1.000
10	开入录波	退出

▲▼ 1/2

图 4.31 基本参数

No.	Basic Parameters	
1	Wiring mode	STAR
2	Nominal current	5.000 A
3	Nominal voltage	57.740 V
4	Voltage class	0.38 kV
5	User agreement capacity	10.000 MVA
6	Min short-circuit capacity	10.000 MVA
7	Device supply capacity	10.000 MVA
8	PT ratio	1.000
9	CT ratio	1.000
10	DI trigger waveform record	OFF

▲▼ 1/2

Fig. 4.31 Basic Parameters

4.4.6.2 用户定值-功能参数

4.4.6.2 Parameters – Function Parameters

"功能参数"菜单用于设置各类电能质量指标的告警功能整定值和功能投退控制字，包括电压上下限，频率上下限等，设置方法同 4.4.6.1，默认密码为"0008"。

Screen "Function Parameters" is used for setting of various power quality indexes and function control, showing maximum and minimum values of voltage, frequency and other data. These parameters can be set as described in 4.4.6.1 and protected by a default password (0008).

装置出厂时所有功能都为投入，其整定值都已按照电能质量相关国家标准要求设置好，如有特殊需求可再修改。

All functions are set "ON" and the settings comply with power quality standards relating to the power quality before delivery of this product. However, they can be modified if required.

例 1 频率偏差功能：需设置"频率上限定值"，"频率下限定值"，投入"频率偏差"控制字。若当前频率高于"频率上限定值"或低于"频率下限定值"，则装置产生频率偏差告警，弹出频率偏差事件记录并触发录波，同时对应的告警继电器出口闭合且面板频率偏差指示灯亮。待频率恢复正常后，按"RST"键，可复归继电器出口和指示灯。

Example 1: Frequency deviation. It is necessary to set "Max frequency" and "Min frequency" and enable "Frequency deviation". When the actual frequency is above the maximum value or below the minimum value, the frequency deviation alarm will be activated. The "Frequency deviation" event will generate and the wave recording will work. Meanwhile, the corresponding digital output is closed and the frequency deviation LED on the panel turns bright. Press "RST" to reset the digital output and the LED when the frequency becomes normal.

例 2 电压暂降功能：需设置"电压暂降"为 90%，投入"暂态电压"控制字，此处 90%含义为 90%*标称电压。如果电压低于 90%*标称电压，并在 1min 内恢复正常。此时触发电压暂降功能，装置弹出电压暂降事件记录并触发录波，同时闭合对应继电器出口和点亮面板指示灯。电压暂降结束后按"RST"键可复归装置。

Example 2: Voltage dip. It is necessary to set the "Voltage dip threshold" to be 90% and enable the "Temporary voltage". Term "90%" means 90% of the nominal voltage. If the actual voltage is below 90% of the nominal voltage and then increases to the normal level in 1min, the voltage dip will be activated, the "Voltage dip" event will generate and the wave recording will work. Meanwhile, the corresponding digital output is closed and the Dip/Swell LED on the panel turns bright. Press "RST" to reset this product at the end of voltage dip event.

通道1 功能参数		
序号		
1	频率上限	50.200 Hz
2	频率下限	49.800 Hz
3	电压上限	107.000 %
4	电压下限	90.000 %
5	电压负序不平衡度限值	4.000 %
6	电流负序不平衡度限值	4.000 %
7	短时闪变限值	1.000 %
8	长时闪变限值	1.000 %
9	电压暂升	110.000 %
10	电压中断	10.000 %

▲▼ 页数1/17 ▶ 通道切换

图 4.32 功能参数

Function Parameters		
No.		
1	Max frequency	50.200 Hz
2	Min frequency	49.800 Hz
3	Max voltage	107.000 %
4	Min voltage	90.000 %
5	Unbalance U2 Limit	4.000 %
6	Unbalance I2 Limit	4.000 %
7	Short-term flicker Limit	1.000%
8	Long-term flicker Limit	1.000 %
9	Voltage swell threshold	110.000 %
10	Voltage interruption threshold	10.000 %

▲▼ 1/17

Fig. 4.32 Function Parameters

4.4.6.3 用户定值-继电器配置

4.4.6.3 Parameters – DO Configuration

继电器配置菜单用于设置电能质量告警功能对应的继电器出口。每一个告警功能可设置为 DO1~ DO4 的任意一个或多个。如表 4.3 所示，每个 DO 可设置为 0、A、B、C，其中 0 表示退出，A 表示保持型出口，B 表示不保持型出口，C 表示脉冲型出口，出口配置显示见图 4.33。

Screen "DO Configuration" is used to set relay outputs corresponding to power quality alarms. Any one or combination of DO1 to DO4 can be set for an alarm. Every DO can be set to 0, A, B or C as listed in Table 4.3. "0" indicates a off output, "A" indicates a bistable output, "B" indicates a monostable output and "C" indicates a impulsive output. To confirm the DO configuration, see Fig. 4.33.

表 4.3 DO 状态表
Table 4.3 DO States

继电器编号 Relay No.	1	2	3	4
对应 DO Corresponding DO	DO1	DO2	DO3	DO4
DO 属性 DO attribute	0/A/B/C	0/A/B/C	0/A/B/C	0/A/B/C

如电压暂升所对应的继电器编号为 A00C，A 对应第 1 个继电器出口 DO1，C 对应第 4 个继电器出口 DO4，则说明 DO1 和 DO4 是电压暂态的告警出口，且 DO1 处于 A 状态(保持状态)，DO4 处于 C 状态(脉冲状态)。

For example, the "temporary voltage" relates to relay number A00C. Letter "A" relates to 1st relay output DO1 and letter "C" relates to 4th relay output DO4, indicating that both DO1 and DO4 are alarm outputs of "Voltage Swell", DO1 is attribute A (bistable) and DO4 is attribute C (impulsive).

出厂默认配置：（DO 出口见装置背后端子 X3 丝印）

Default settings: (see description of terminal X4 on the back for DO outputs)

表 4.4 出厂默认配置表
Table 4.4 Factory Default

功能名称 Function	配置 DO DO configuration	DO 属性 DO attribute	功能名称 Function	配置 DO DO configuration	DO 属性 DO attribute
电压暂升 Voltage swell	DO1	保持 Bistable	电流不平衡 Current unbalance	DO4	保持 Bistable
电压暂降 Voltage dip	DO1	保持 Bistable	电压闪变 Voltage flicker	DO1	保持 Bistable
电压中断 Voltage interruption	DO1	保持 Bistable	谐波电压 Voltage harmonic	DO2	保持 Bistable
瞬态电压 Transient volt	DO2	保持 Bistable	谐波电流 Current harmonic	DO2	保持 Bistable
瞬态电流 Transient curr	DO2	保持 Bistable	直流电压 Voltage DC	DO3	保持 Bistable
频率偏差 Frequency deviation	DO3	保持 Bistable	直流电流 Current DC	DO3	保持 Bistable
电压偏差 Voltage deviation	DO3	保持 Bistable	电压快速变化 Rapid voltage change	DO4	保持 Bistable
电压不平衡 Voltage unbalance	DO4	保持 Bistable	冲击电流 Inrush current	DO1	保持 Bistable

注 1：同一个 DO 可以被配置到多个功能下，同一个功能可以配置多个 DO。

Note 1. One DO can be related to several functions and one function can be allocated with more than one DO.

注 2: 一个 DO 可以有多种输出状态, 即同一个 DO 可配置为不同告警功能, 其输出状态可分别设为保持型、不保持型、脉冲型, 如 DO1 在暂态电压功能设为 A 状态、而在瞬态电压功能时设为 B/C 状态。

Note 2. A DO may permit several output states. In other words, a DO can be set for different alarms and its output attribute may be bistable, monostable or impulsive. For example, DO1 is attribute A for temporary voltage while it is attribute B or C for transient voltage.

告警	属性
电压暂升	A 0 0 0
电压暂降	A 0 0 0
电压中断	A 0 0 0
瞬态电压	A 0 0 0
瞬态电流	A 0 0 0
频率偏差	0 0 A 0
电压偏差	0 0 A 0
电压不平衡	0 0 0 A
电流不平衡	0 0 0 A
电压闪变	0 0 0 0

图 4.33 继电器配置显示界面

Alarm	Attribute
Voltage swell	A 0 0 0
Voltage dip	A 0 0 0
Voltage interruption	A 0 0 0
Transient voltage	A 0 0 0
Transient current	A 0 0 0
Frequency deviation	0 0 A 0
Voltage deviation	0 0 A 0
Voltage unbalance	0 0 0 A
Current unbalance	0 0 0 A
Voltage flicker	0 0 0 0

Fig. 4.33 DO Configuration

在继电器配置界面, 所有继电器功能默认为退出, 按"确认键", 进入功能选择, 按左右键移动光标进行配置。如图 4.34(a)和图 4.34(b)。

All relay functions are off by default. Press "↵" to select the desired function and make the configuration with ◀ or ▶ as shown in Fig. 4.33(a) and Fig. 4.33(b).

DO编号	投退		属性		
1	投入	退出	保持	不保持	脉冲
2	投入	退出	保持	不保持	脉冲
3	投入	退出	保持	不保持	脉冲
4	投入	退出	保持	不保持	脉冲

图 4.34(a) 继电器配置界面

DO No.	ON/OFF		Attribute		
1	ON	OFF	Bistable	Monostable	Impulsive
2	ON	OFF	Bistable	Monostable	Impulsive
3	ON	OFF	Bistable	Monostable	Impulsive
4	ON	OFF	Bistable	Monostable	Impulsive

Fig. 4.34(a) Relay Setting

DO编号	投退		属性		
1	投入	退出	保持	不保持	脉冲
2	投入	退出	保持	不保持	脉冲
3	投入	退出	保持	不保持	脉冲
4	投入	退出	保持	不保持	脉冲

图 4.34(b) 继电器配置界面

DO No.	ON/OFF		Attribute		
1	ON	OFF	Bistable	Monostable	Impulsive
2	ON	OFF	Bistable	Monostable	Impulsive
3	ON	OFF	Bistable	Monostable	Impulsive
4	ON	OFF	Bistable	Monostable	Impulsive

Fig. 4.34(b) Relay Setting

4.4.7 系统设置

4.4.7 System Setup

系统设置菜单设置密码为"0008"。

Screen "System Setup" is encrypted with a password (0008).

在主菜单选择"系统设置"菜单，按"确认键"进入系统设置菜单。系统设置菜单由"通讯设置"、"显示设置"、"装置信息"组成。

Select "System Setup" on main menu and open submenu "System Setup" with button "↵". Submenu "System Setup" provides three screens, i.e. "Communication", "Display" and "Information".



图 4.35 系统设置



Fig. 4.35 System Setup

4.4.7.1 系统设置-通讯设置

4.4.7.1 System Setup – Communication

通讯设置主要用来设置以太网通讯和 RS485 串行通讯参数。

Screen "Communication" is used to configure Ethernet communication and RS485 serial communication parameters.

装置出厂：以太网 1IP 地址：172.22.60.99

以太网 2IP 地址：172.23.60.99

Default: IP address of Ethernet 1: 172.22.60.99

IP address of Ethernet 2: 172.23.60.99

(注：更改以太网口 IP 地址时，不同网口不能设置为同一网段，Modbus 默认端口为 8080)

(Note: The IP address of different Ethernet network interfaces cannot be set in the same network segment and the modbus interface is 8080 by default)

以太网 1	IP地址:	192.168.096.009
	子网掩码:	255.255.255.000
	默认网关:	192.168.096.001
	MAC地址:	34:43:35:41:35:38
	通讯协议:	ModbusTCP
串口 1	装置地址:	0007
	波特率:	19200
	数据位:	8
	停止位:	1
	校验方式:	无校验
	通讯协议:	Modbus RTU

▶ 翻页1/4

图 4.36 通讯设置

E t h 1	IP :	192.168.096.009
	Mask:	255.255.255.000
	Gateway:	192.168.096.001
	Mac :	34:43:35:41:35:38
	Protocol:	ModbusTCP
S e r i a l 1	Address:	0007
	Baud rate:	19200
	Data bit:	8
	Stop bit:	1
	Parity:	Disable
	Protocol:	ModbusRTU

Fig. 4.36 Communication setup

4.4.7.2 系统设置-显示设置

4.4.7.2 System Setup – Display

"显示设置"用来设置语言、对比度(0-99)、自动熄屏时间(10-999 秒)、系统时间等。设置密码为"0008"。

Screen "Display" indicates language, contrast (0-99),backlight time (10-999s) and system time. It is encrypted with a password (0008).

显示设置	
语言设置	中文
对比度	90
背光时间	0 s
时间设置	
设定时间	2023-10-31 14:02:40
装置时间	2023-10-31 14:03:12

图 4.37 显示设置

Config display	
Language	English
Contrast	90
BackLight time	0 S
Config time	
Set time	2023-10-31 14:02:40
Device time	2023-10-31 14:03:12

Fig. 4.37 Display setup

4.4.7.3 系统设置-装置信息

4.4.7.3 System Setup – Information

装置信息界面显示当前装置版本信息。

Screen "Information" contains the information on the current version of this product.

```

FSBL:2018.3_2022-11-11_10:17:50
PL:220526B
U-BOOT:2018.01
CPU1:V1.03_2022-12-09_10:18:43
BOOT:V1.03_2022-12-09_10:18:43
KERNEL:Linux-4.14.0-xilinx
DTB:V2.00_20220617
ROOTFS:V0.99
APP:V1.03_2022-12-08_16:54:51
MMI:V1.13_2022-11-20_15:40:45

Device ID:044CBCFD64FA
61850 license:123456789ABC(UNPASS)
SM4 ECB key:7AAkPceVryieelw7

```

图 4.38 装置信息

```
FSBL:2018.3_2022-11-11_10:17:50
PL:220526B
U-BOOT:2018.01
CPU1:V1.03_2022-12-09_10:18:43
BOOT:V1.03_2022-12-09_10:18:43
KERNEL:Linux-4.14.0-xilinx
DTB:V2.00_20220617
ROOTFS:VO.99
APP:V1.03_2022-12-08_16:54:51
MMI:V1.13_2022-11-20_15:40:45

Device ID:044CB6CFD64FA
61850 license:123456789ABC(UNPASS)
SM4 ECB key:7AAkPceVryieelw7
```

Fig. 4.38 Information

4.4.8 装置调试菜单

4.4.8 Debug

在主菜单选择"装置调试", 进入装置调试菜单。装置调试菜单有"零漂调整"、"幅值调整"、"开入显示"、"信号开出"、"指示灯"五个子菜单。

Select "Debug" on main menu and open submenu "Debug". Submenu "Debug" provides four screens, i.e. "Zero Adjust", "Amplitude Adjust", "DO Test" and "Lamp Test".

此菜单用于测试装置的硬件功能, 建议使用时请与厂家联系。

It is used to test the hardware function. Please contact the manufacturer before debugging.



图 4.39 装置调试



Fig. 4.39 Debug

5 定值清单

5 List of parameter

	序号 No.	参数名称 Parameter	单位 Unit
基本参数 Basic Parameters	1	接线方式 Wiring mode	0-Y 型 (3PT) 0-STAR (3PT) 1-V 型 (2PT) 1-DELTA (2PT) 2-DC 型 (DC) 2-DC (DC)
	2	标称电流 Nominal current	A
	3	标称电压 Nominal voltage	V
	4	电压等级 Voltage class	kV
	5	用户协议容量 User agreement capacity	MVA
	6	最小短路容量 Min short-circuit capacity	MVA
	7	供电设备容量 Device supply capacity	MVA
	8	PT 变比 PT ratio	
	9	CT 变比 CT ratio	
	10	开入录波 DI trigger waveform record	0-退出 0-OFF 1-开入 1 1-DI_1 2-开入 2 2-DI_2 3-开入 3 3-DI_3 4-开入 4 4-DI_4 5-开入 5 5-DI_5
	11	定时录波开始时间 Timing waveform rcd start time	年月日时分秒 D/M/Y, hour: minute: second
	12	定时录波次数 Timing waveform rcd cnt	次 Number
	13	定时录波时间间隔 Timing waveform rcd time span	s
	14	录波持续时间 waveform rcd duration	s
	15	录波周波采样点数 Sample cnt per cycle	0-32 点 0-32 points 1-64 点 1-64 points 2-128 点 2-128 points 3-256 点 3-256 points

			4-512 点 5-1024 点	4-512 points 5-1024 points
	16	事件录波前周波数 Waveform cnt before event	周波 Cycle	
	17	事件录波后周波数 Waveform cnt after event	周波 Cycle	
功能参数 Function Parameters	18	频率上限 Max frequency	Hz	
	19	频率下限 Min frequency	Hz	
	20	电压上限 Max voltage	%	
	21	电压下限 Min voltage	%	
	22	电压负序不平衡度限值 Unbalance U2 limit	%	
	23	电流负序不平衡度限值 Unbalance I2 limit	%	
	24	短时闪变限值 Short-term flicker limit	%	
	25	长时闪变限值 Long-term flicker limit	%	
	26	电压暂升 Voltage swell threshold	%	
	27	电压中断 Voltage interruption threshold	%	
	28	电压暂降 voltage dip threshold	%	
	29	电压暂升迟滞 Voltage swell hysteresis	%	
	30	电压中断迟滞 Voltage interruption hysteresis	%	
	31	电压暂降迟滞 voltage dip hysteresis	%	
	32	电流瞬态定值 Transient current threshold	%	
	33	电压瞬态定值 Transient voltage threshold	%	
	34	电压总畸变定值 Voltage THD threshold	%	
	35	电流总畸变定值 Current THD threshold	%	
	36	奇次谐波电压定值 Total odd harmonic U threshold	%	

37	偶次谐波电压定值 Total even harmonic U threshold	%
38	直流电压含有率限值 Voltage DC ratio limit	%
39	直流电流分量限值 Current DC ratio limit	%
40	快速电压变化限值 RVC limit	%
41	快速电压变化迟滞 RVC hysteresis	%
42	冲击电流限值 Inrush current limit	%
43	冲击电流迟滞 Inrush current hysteresis	%
44	2次谐波电压定值 Voltage 2nd harmonic limit	%
...	%
105	63次谐波电压定值 Voltage 63rd harmonic limit	%
106	2次谐波电流定值 Current 2 nd harmonic limit	A
...	A
167	63次谐波电流定值 Current 63 rd harmonic limit	A
168	暂态电压 Temporary voltage	0-退出 OFF 1-投入 ON
169	瞬态电压 Transient voltage	0-退出 OFF 1-投入 ON
170	瞬态电流 Transient current	0-退出 OFF 1-投入 ON
171	频率偏差 Frequency deviation	0-退出 OFF 1-投入 ON
172	电压偏差 Voltage deviation	0-退出 OFF 1-投入 ON
173	电压不平衡 Voltage unbalance	0-退出 OFF 1-投入 ON
174	电流不平衡 Current unbalance	0-退出 OFF 1-投入 ON
175	长时闪变 Long-term flicker	0-退出 OFF 1-投入 ON
176	短时闪变 Short-term flicker	0-退出 OFF 1-投入 ON
177	电压总畸变率	0-退出 OFF

		Voltage THD rate	1-投入 ON
178		电流总畸变率 Current THD rate	0-退出 OFF 1-投入 ON
179		奇次谐波电压 Total odd harmonic voltage	0-退出 OFF 1-投入 ON
180		偶次谐波电压 Total even harmonic voltage	0-退出 OFF 1-投入 ON
181		各次谐波电压含有率 Harmonic voltage ratio	0-退出 OFF 1-投入 ON
182		各次谐波电流 Harmonic current	0-退出 OFF 1-投入 ON
183		Voltage DC ratio 直流电压含有率	0-退出 OFF 1-投入 ON
184		Current DC component 直流电流分量	0-退出 OFF 1-投入 ON
185		Rapid voltage change 快速电压变化	0-退出 OFF 1-投入 ON
186		Inrush current 冲击电流	0-退出 OFF 1-投入 ON

6 技术说明

6 Technical instructions

6.1 电压偏差

6.1 Voltage deviation

电压偏差定义：实际运行电压对系统标称电压的偏差相对值，以百分数表示。

Definition: relative deviation of actual working voltage to the nominal voltage, represented in %.

计算公式：

$$\text{电压偏差}(\%) = \frac{\text{电压测量值} - \text{系统标称电压}}{\text{系统标称电压}} \times 100\%$$

Formula:

$$\text{Voltage deviation}(\%) = \frac{\text{Actual voltage} - \text{Nominal voltage}}{\text{Nominal voltage}} \times 100\%$$

标准要求：GB/T 12325 电能质量 供电电压偏差

Standard requirements: GB/T 12325 *Power quality— Deviation of supply voltage*

1、35kV及以上供电电压正、负偏差绝对值之和不超过标称电压的10%。

For 35kV and higher voltage class, the sum of absolute value of positive and negative deviations shall not exceed 10% of the nominal voltage.

2、20kV及以下三相供电电压偏差为标称电压的±7%。

For 20kV and lower voltage class, the voltage deviation shall be ±7% of the nominal voltage.

3、220V 单相供电电压偏差为标称电压的+7%，-10%。

For 220V single-phase supply voltage, the voltage deviation shall be +7% or -10% of the nominal voltage.

调试方法 Debugging method:

1、投入"电压偏差"功能；

Enable function "Voltage deviation".

2、设定"电压上限值"=110%；"电压下限值"=90%

Set "max voltage" to be 110% and "min voltage" to be 90%.

在电压输入端子上接入系统标称电压持续时间12s(用于判定系统带电稳定),将电压升高高于"电压上限值"(110%*标称电压)持续时间超过1min(如若短与1min判定为电压暂升),触发电压上偏差事件。电压下偏差同理。

Supply the nominal voltage to the voltage input terminal of device for 12s (to determine the running stability with electricity). Increase the voltage above the "max voltage" (i.e. 110% of the nominal voltage) and hold it for more than 1min, which will result in the "Deviation over voltage" event. It is similar to the "Voltage under-deviation" event. (If the voltage above the max voltage lasts for less than 1min, it will be determined as voltage swell.)

6.2 频率偏差

6.2 Frequency deviation

频率偏差定义:系统频率的实际值和标称值之差。

Definition: difference between the actual frequency and nominal frequency

计算公式:

$$\text{频率偏差} = \text{实际偏差} - \text{标称偏差}$$

Formula:

$$\text{Frequency deviation} = \text{Actual frequency} - \text{Nominal frequency}$$

标准要求: GB/T 15945 电能质量 电力系统频率偏差

Standard requirements: GB/T 15945 *Power quality—Frequency deviation for power system*

电力系统正常运行条件下频率偏差限值为 $\pm 0.2\text{Hz}$ 。当系统容量较小时，偏差值可以放宽到 $\pm 0.5\text{Hz}$ 。

The frequency deviation shall be limited to $\pm 0.2\text{Hz}$ under the normal working conditions of the electric power system. If the system capacity is relatively small, the deviation range may be extended to $\pm 0.5\text{Hz}$.

调试方法 Debugging method:

1、投入"频率偏差"功能:

Enable function "Frequency deviation".

2、设定"频率上限"= 50.10Hz ，"频率下限"= 49.9Hz ;

Set "Max frequency" to be 50.10Hz and "Min frequency" to be 49.9Hz .

在电压输入端子上接入三相 50Hz 系统标称电压信号稳定 12s（用于判定系统带电稳定），将频率升高至"频率上限"以上，触发频率上偏差告警，频率下偏差同理。

Supply a 3-phase nominal voltage of 50Hz to the voltage input terminal for 12s (to determine the running stability with electricity). Increase the frequency

above the "Max frequency", which will result in the "Deviation over frequency" event. It is similar to the "Deviation under frequency" event.

6.3 谐波

6.3 Harmonics

谐波定义: 对周期性交流量进行傅立叶级数分解, 得到频率为基波频率大于 1 整数倍的分量。

Definition: frequency components greater than one integer multiple of the fundamental frequency after cyclical AC voltage/current are decomposed by Fourier series

标准要求: GB/T 14549 电能质量公用电网谐波

Standard requirements: GB/T 14549 *Quality of electric energy supply—Harmonics in public supply network*

表 6.1 谐波电压限值
Table 6.1 Limit of harmonic voltage

电网标称电压 kV Nominal voltage class	电网总谐波畸变率% Total harmonic distortion(THD%)	各次谐波电压含有率% Harmonic voltage ratio	
		奇次 Odd	偶次 Even
0.38	5.0	4.0	2.0
6	4.0	3.2	1.6
10			
35	3.0	2.4	1.2
66			
110	2.0	1.6	0.8

产生原因: 谐波主要是由电力系统或负荷的非线性特性引起的。电力系统中的电力电子设备是谐波的主要来源, 除此之外, 产生电弧的负荷, 工作在铁磁非线性状态的电力、电气设备, 也会产生谐波。这些设备和负荷, 通常可以表征为谐波电流源, 向电力系统注入谐波电流。谐波畸变程度可以由谐波频谱范围、每个谐波分量的幅值和相位角来描述。也可以使用单一的量值, 即总谐波畸变率(THD)来衡量波形畸变的程度。

Causes. Harmonics are mainly caused by the nonlinear characteristics of power systems or loads. The electronic equipment in power system is the main source of harmonics. Other sources include loads that generate electric arcs and electrical equipment operating in a ferromagnetic nonlinear state. Such equipment and loads, which are often represented as harmonic current sources, will supply harmonic current to the power system. The degree of harmonic distortion can be described by the harmonic

spectral range as well as the amplitude and phase angle of each harmonic component. Alternatively, it can be represented by a single quantity, namely the total harmonic distortion (THD).

危害: 非线性负荷注入供电系统的谐波电流引起电力系统的谐波电压。谐波电流和谐波电压会导致旋转设备、变压器和载流导线过热，熔断器烧毁。

Hazards. The harmonic current that is generated by nonlinear loads will result in the harmonic voltage in the power system. Harmonic current and voltage may cause overheating of rotating equipment, transformers and live wires and burning of fuses.

调试方法 Debugging method:

1、投入"各次谐波电流"或各次"谐波电压含有率".

Enable "Harmonic current" or "Harmonic voltage ratio".

2、设定某次"谐波定值", 施加含有谐波的电流或电压;

Set the harmonic parameters and input the harmonic current or voltage.

施加三相电压信号, 若某次谐波大于"谐波定值"产生相应告警。

An alarm will be triggered if the harmonics exceeds the parameters.

6.3.1 总谐波畸变率

6.3.1 Total harmonic distortion(THD)

总谐波畸变率 THD: 周期性交变量中的谐波含量的方均根值与其基波分量的方均根值之比, 用百分数表示。波形畸变是指某些电力、电气设备所具有的电压与电流的非线性特征使它们波形偏离正弦波的变化。常见的五种主要类型的波形畸变包括, 直流偏置、谐波、间谐波、电压缺口和噪声(悬置段)。

Total harmonic distortion THD: Ratio of the RMS value of harmonic components to the RMS of fundamental component in cyclical AC voltage/current, represented in %. The waveform distortion indicates the waveform deviation from the sine wave caused by the nonlinear characteristics of voltage and current of some electrical equipment. There are five main types of waveform distortion, i.e. DC bias, harmonics, Interharmonics, voltage gap and noise (suspended).

电压总谐波畸变率以 THD_u 表示。电流总谐波畸变率以 THD_i 表示。

The symbol of total harmonic distortion of voltage is THD_u and the symbol of total harmonic distortion of current is THD_i .

计算公式 Formula:

$$THD_u = \frac{\sqrt{\sum_{h=2}^{\infty} (U_h)^2}}{U_1} \times 100\%, THD_i = \frac{\sqrt{\sum_{h=2}^{\infty} (I_h)^2}}{I_1} \times 100\%$$

式中 In the formula:

U_h — Harmonic voltage of order h (RMS)

U_1 — Fundamental voltage (RMS)

I_h — Harmonic current of order h (RMS)

I_1 — Fundamental current (RMS)

6.3.2 K 因子

6.3.2 K-factor

K 因子: 在电能质量的技术指标中, K 因子主要是反映非线性负荷引起的谐波的频率对变压器损耗的影响。K 因子的定义主要是在假定由谐波电流引起的变压器涡流损耗与谐波次数的平方成比例。

K-factor. Among the technical indexes of power quality, the K-factor mainly reflects the effect of the frequency of harmonics caused by nonlinear loads on transformer loss. The definition of the K-factor is mainly based on the assumption that the eddy current loss of transformer caused by harmonic currents are proportional to the square of the number of harmonics.

计算公式 Formula:

$$K = \frac{\sum_{h=1}^{h=h_{\max}} I_h^2 h^2}{\sum_{h=1}^{h=h_{\max}} I_h^2}$$

式中 In the formula:

h — The order of harmonics

I_h — RMS of harmonic current of order h

h_{\max} — The maximum order of calculated harmonic current, 63

6.3.3 峰值因子

6.3.3 Crest factor

峰值因子: 波峰系数是指波形峰值与有效值的比。标准正弦波峰值因子为 1.414。

Crest factor: The crest factor is the ratio of the wave peak value to the RMS. The crest factor of standard sine wave is 1.414.

计算公式:

$$Crestfactor = \frac{\text{测量峰值}}{\text{有效值}(RMS)}$$

Formula:

$$Crestfactor = \frac{Peak\ value}{RMS}$$

6.3.4 总需量畸变

6.3.4 Total demand distortion(TDD)

总需量畸变率 TDD: 计 50 次及以下谐波分量(不包括间谐波)的谐波电流含量的方均根值与最大需量负荷电流之比, 用百分数表示。

Total demand distortion TDD: the ratio of the RMS of harmonic current of harmonic components up to 50 cycles (excluding Interharmonics) to the maximum demand load current, represented in %.

计算公式 Formula:

$$TDD = \frac{\sqrt{\sum_{h=2}^{\infty} I_h^2}}{I_L} \times 100\%$$

式中 In the formula:

I_h —谐波电流分量 Harmonic current component

h —谐波次数 Order of harmonics

I_L —最大需量负荷电流 Max demand load current

6.4 间谐波

6.4 Interharmonics

间谐波定义: 对周期性交流量进行傅立叶级数分解, 得到频率不等于基波频率整数倍的分量。

Definition: frequency components other than integer multiples of the fundamental frequency after cyclical AC voltage/current are decomposed by Fourier series

标准要求: GB/T 24337 电能质量 公用电网间谐波

Standard requirements: GB/T 24337 *Power quality— Interharmonics in public supply network*

表 6.2 间谐波电压含有率限值

Table 6.2 Limit of interharmonic voltage ratio

电压等级 Voltage class	频率 Frequency/Hz	
	<100	100~800
1000V 及以下 ≤1000V	0.2	0.5
1000V 以上 >1000V	0.16	0.4

产生原因: 间谐波往往由较大的电压波动或冲击性非线性负载引起, 所有非线性的波动负荷, 如电弧炉、电焊机、各种变频器装置、同步串级调速装置及感应电动机等产生间谐波, 电力载波信号也是一种间谐波。

Causes. It is often caused by great voltage fluctuations or impact nonlinear loads. All nonlinear wave loads generate Interharmonics, including electric arc furnaces, electric welding machines, various frequency converters, synchronous cascade speed controls and induction motors. And the power line carrier signals are also a kind of Interharmonics.

6.5 不平衡度

6.5 Unbalance

不平衡度: 不平衡度指三相电力系统中三相不平衡的程度, 用电压、电流负序基波分量或零序基波分量与正序基波分量的方均根值百分比表示。

Unbalance: the RMS ratio of the negative sequence or zero sequence fundamental component of voltage/ current to the positive sequence fundamental component, indicating the degree of unbalance among three phases in a 3-phase power system, represented in %.

计算公式 Formula:

$$\varepsilon_{U2} = \frac{U_2}{U_1} \times 100\%, \varepsilon_{U0} = \frac{U_0}{U_1} \times 100\%$$

式中 In the formula:

U_1 —三相电压的正序分量方均根值

RMS of positive sequence component of 3-phase voltage

U_2 —三相电压的负序分量方均根值

RMS of negative sequence component of 3-phase voltage

U_0 —三相电压的零序分量方均根值

RMS of zero sequence component of 3-phase voltage

将式中 U_1 、 U_2 、 U_0 换为 I_1 、 I_2 、 I_0 则为相应的电流不平衡度 ε_{12} 和 ε_{10} 的表达式。

Change the "U" to "I", it is the I Unbalance.

产生原因：三相不平衡是指三相系统的工频相电压(电流)在幅值上不同或器相位差不是 120° 。用户在使用过程中发生三相不平衡的主要原因如下：

Causes. 3-phase unbalance refers to the amplitude inconsistency of phase voltage (current) in a 3-phase system or deviation of phase difference from 120° . Such unbalance may occur under conditions including but not limited to:

1) 各相负荷分布不平衡

Unbalanced load distribution among phases

2) 高次谐波电流使各相之间发生不平衡

Higher harmonics

3) 接线端子及电缆接触不良附加的不平衡

Poor connection of wiring terminals or cables

4) 外部环境导致不平衡的发生(如施工等导致线路断开)

External conditions, such as open circuit caused by improper construction

5) 不换位的长距离架空输配电线路

Long distance overhead transmission and distribution lines without transposition

危害：电压不平衡主要危害是电机和变压器很容易出现过热，旋转设备振动。

Hazards. The main hazards of voltage unbalance include the easy overheating of motors and transformers and vibration of rotating equipment.

标准要求：DL/T 1375 电能质量评估技术导则 三相电压不平衡

Standard requirements: DL/T 1375 *Technical guide for power quality evaluation – 3-phase voltage unbalance*

电网正常运行时，负序电压不平衡度不超过 2%，短时不得超过 4%。

The negative sequence voltage unbalance shall not exceed 2% (4% for a short period) when the power grid works normally.

6.6 电压波动与闪变

6.6 Voltage fluctuation and flicker

6.6.1 电压波动

6.6.1 Voltage fluctuation

电压波动：基波电压方均根值(有效值)一系列的变动或连续的改变。电压变动 d 和电压变动频度 r 则是衡量电压波动大小和快慢的指标。电压波动是电压方均根值一系列快速变动

或连续改变的现象，其变化周期大于工频周期(20ms)。电压波动时的电压方均根值一般在电压许可偏差的范围内。

Voltage fluctuation: a series of changes or continuous changes in the RMS (effective value) of fundamental voltage. Voltage change d and rate of occurrence of voltage changes r are used to measure the degree and speed of voltage fluctuation. It is a phenomenon describing a series of rapid changes or continuous changes in the RMS of voltage. The period of change is longer than the frequency cycle (20ms). During voltage fluctuations, the RMS of voltage is generally within the permissible range of the voltage.

计算公式 Formula:

$$d = \frac{\Delta U}{U_N} \times 100\%$$

式中 In the formula:

ΔU —电压方均根值曲线上相邻两个极值电压之差

Difference between two adjacent peak voltages on the RMS curve of voltage

U_N —系统标称电压

Nominal voltage

产生原因: 任何负载的周期性变化，特别是无功分量，会引起电压波动。电压波动引起灯光强弱的变化称作"闪变"。在输电和配电系统中，电弧炉、变频调速是导致电压波动的最常见原因，接入电网的风电机组在持续的运行和切换操作过程中都会产生电压波动。

Causes. Any cyclical change of loads, particularly the reactive component, causes voltage fluctuations. Changes in light intensity as a result of voltage fluctuation are called "flicker". Regarding transmission and distribution systems, arc furnaces and variable frequency governors are the most common causes of voltage fluctuations. In addition, wind turbines connected to the power grid also generate voltage fluctuations when they run continuously or make a switchover.

标准要求: GB/T 12326 电能质量 电压波动和闪变

Standard requirements: GB/T 12326 *Power quality—Voltage fluctuation and flicker*

表 6.3 电压波动限值

Table 6.3 Limit of voltage fluctuation

电压变动频度 r (次/h) Rate of voltage changes r /(changes/h)	$d/\%$	
	LV、MV	HV
$r \leq 1$	4	3
$1 < r \leq 10$	3	2.5
$10 < r \leq 100$	2	1.5
$100 < r \leq 1000$	1.25	1

注：参照 GB/T 156-2007，本标准中系统标称电压 U_N 等级以下划分：

Note: Refer to GB/T 156-2007. This standard classifies the nominal voltage U_N as follows:

- 低压 Low voltage (LV) $U_N \leq 1kV$
- 中压 Medium voltage (MV) $1kV < U_N \leq 35kV$
- 高压 High voltage (HV) $35kV < U_N \leq 220kV$

6.6.2 电压闪变

6.6.2 Voltage flicker

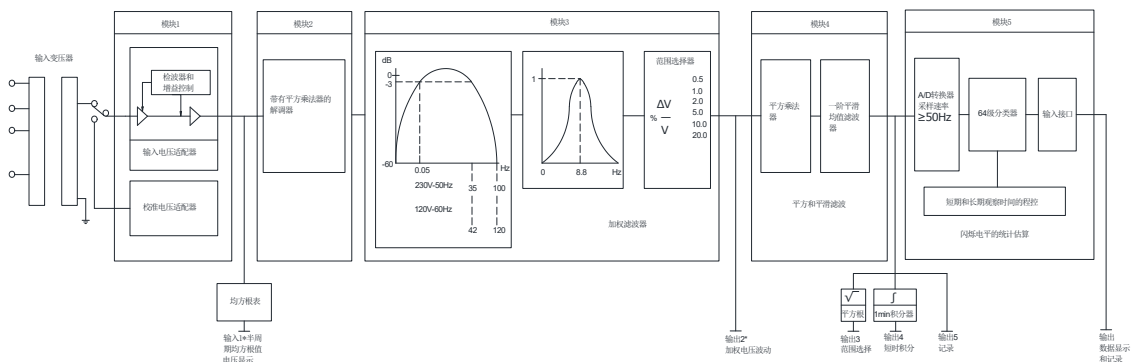
闪变： 灯光照度不稳定照成的视感。

Flicker: visual perception caused by unstable light

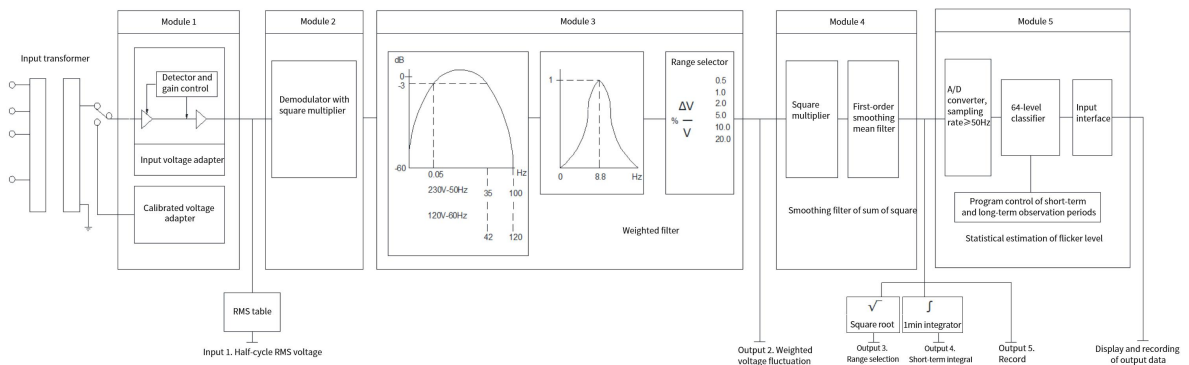
短时间闪变值 Pst: 衡量短时间(若干分钟)内闪变强弱的一个统计量值，短时间闪变的基本记录周期为 10min。

Short-term flicker Pst: a statistical value of the flicker intensity over a short period of time (e.g. several minutes). Basically, the short-time flicker is recorded every 10 min.

短闪变计算方法见下图：



The following figure illustrates how to calculate the short-term flicker:



长时间闪变值 Plt: 由短时间闪变值 Pst 推算出, 反映长时间 (若干小时) 闪变强弱的量值, 长时间闪变的基本记录周期为 2h。

Long-term flicker Plt: a statistical value that is derived from short-term flicker Pst and reflects the flicker intensity over a long period of time (several hours). Basically, the long-time flicker is recorded every 2h.

计算公式 Formula:

$$P_{lt} = \sqrt[3]{\frac{1}{12} \sum_{j=1}^{12} (P_{stj})^3}$$

式中 In the formula:

P_{stj} —2h 内第 j 个短时间闪变值 Short-term flicker of period j within 2h

危害: 闪变反映了电压波动引起的灯光闪烁对人视感产生的影响, 是电压波动造成的一种不良后果。例如。频率在 8.8Hz, 波动幅值达到工频电压幅值的 0.25% 的电压波动加在白炽灯上, 就会使人感觉到视觉不适和疲劳。

Hazards. Flicker reflects the effect of light flickering on the human visual perception, which is an undesirable consequence of voltage fluctuations. For example, when an incandescent lamp works at 8.8Hz and a voltage fluctuation equal to 0.25% of power frequency voltage, its user will feel visual discomfort and fatigue.

标准要求: GB/T 12326 电能质量 电压波动和闪变

Standard requirements: GB/T 12326 *Power quality—Voltage fluctuation and flicker*

表 6.4 闪变限值

Table 6.4 Flicker Limit

P_{lt}	
$\leq 110kV$	$> 110kV$
1	0.8

调试方法 Debugging method:

1、投入"电压长闪变", "电压短闪变"控制字;

Enable the control of "Long-term flicker" and "Short-term flicker".

2、设定"短时闪变限值"为 1, "长时闪变限值"为 1;

Set both "Short-term flicker limit" and "Long-term flicker limit" to be 1.

用电能质量标准源施加闪变信号 $Pst=2$, 整点 10 分钟, 触发闪变越限, 整点 2 小时后触发长闪变越限。

Apply a standard power quality source to send the flicker signal $P_{st} = 2$.
The "Short-term flicker" will be activated in 10 minutes and the "Long-term flicker" will be activated in 2 hours.

6.7 电压暂升、暂降、中断

6.7 Voltage swell, dip and interruption

6.7.1 电压暂降

6.7.1 voltage dip

电压暂降是电力系统中某点工频电压方均根值突然降低至 $0.1p.u. \sim 0.9p.u.$ 并在短暂持续 $10ms \sim 1min$ 后恢复正常的现象。

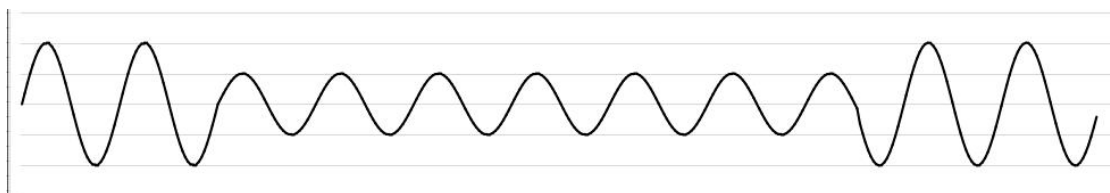
voltage dip is a phenomenon that the RMS voltage in a power system suddenly reduces to $0.1p.u.$ to $0.9p.u.$ and returns to normal in a short period from $10ms$ to $1min$.

产生原因: 电压暂降通常与系统故障有关,也可以由大容量感应电动机启动或变压器空载激磁等原因产生。大容量感应电动机启动会引起电压暂降。电动机启动会产生 6 倍~10 倍的额定电流。这个大电流通过系统阻抗引起电压下降。变压器空载接入电网时,由于变压器磁通饱和以及剩磁的作用,可能出现很大的冲击电流,造成电压暂降。

Causes. voltage dip is usually related to system faults. In addition, starting of large-capacity induction motors or no-load excitation of transformers may also be causes. When a large-capacity induction motor starts, it may result in voltage dips. When a motor starts, it will generate a current 6 to 10 times than the rated value. Under the effect of system impedance, it will cause voltage dips. If a transformer is connected to the power grid without load, it may generate a large impact current because of flux saturation and remanence and thus result in voltage dips.

危害: 现有的精密制造设备、计算机、变频器、各种微电子装置和自动调速装置等用电负载对电压暂降均非常敏感,持续 $16ms$ 的幅值为额定值 $85\% \sim 90\%$ 电压暂降即可能导致设备停机。电压暂降波形见下图:

Hazards. Electrical loads are very sensitive to voltage dips, including but not limited to precision manufacturing equipment, computers, frequency converter, microelectronic devices and automatic speed governors. voltage dip with the amplitude of 85% to 90% of the normal voltage may make equipment shut down if it lasts for $16ms$. The following figure illustrates the waveform of voltage dip:



6.7.2 短时中断

6.7.2 Voltage interruption

短时中断是电力系统中某点工频电压方均根值突然降低至 0.1p.u. 以下，并在短暂持续 10ms~1min 后恢复正常的现象。

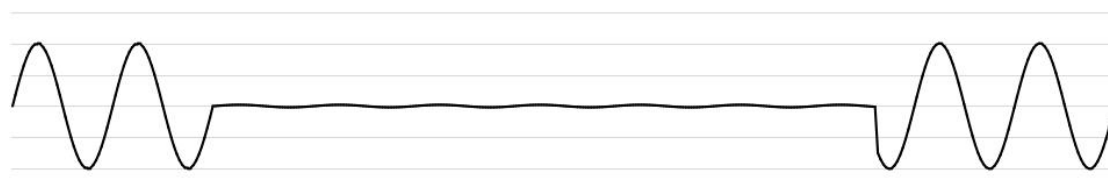
Short-term interruption is a phenomenon that the RMS voltage in a power system suddenly reduces below 0.1p.u. and returns to normal in a short period from 10ms to 1min.

产生原因：电力系统故障、设备故障、控制失灵均会引起短时中断。短时中断是根据电压方均根值小于标称值 10% 的持续时间来衡量的。系统故障持续时间由保护装置动作时间或特殊事件过程时间决定。

Causes. Power system faults, equipment malfunctions and control failures can cause short-term interruptions. Short-term interruptions are measured by the duration of RMS voltage below 10% of the nominal value. The duration of a system fault is determined by the working time of the corresponding protective device or the duration of a special event.

危害：电压短时中断可能会影响电子和照明设备，并导致误操作或关机。在某些情况下，电压短时中断，在电压突然恢复时，短时中断可能会损坏电子设备。电压短时中断波形见下图：

Hazards. voltage interruption may affect electronic and lighting equipment and further cause misoperation or shutdown. In some cases, electronic equipment may be damaged when the voltage is suddenly restored from a voltage interruption. The following figure illustrates the waveform of voltage interruption:



6.7.3 电压暂升

6.7.3 Voltage swell

电压暂升是电力系统中某点工频电压方均根值暂时升高至 1.1p.u.~1.8p.u.，并在短暂持续 10ms~1min 后恢复正常的现象。

Voltage swell is a phenomenon that the RMS voltage of in a power system suddenly increases to 1.1p.u. to 1.8 p.u. and returns to normal in a short period from 10ms to 1min.

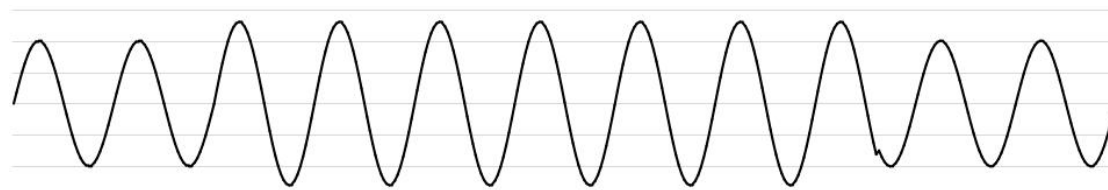
产生原因：在中性点不接地电力系统发生单相接地故障时会导致非故障相电压升高。大容量负荷退出、甩负荷或大容量电容器组投入等事件也会造成暂升。

Causes. When an single-phase earth fault occurs in a power system without the earthed neutral point, the voltage of other phases will rise. Voltage swell may also be

caused by removal of large-capacity loads, load shedding or operation of large-capacity capacitor bank.

危害: 电压暂升可能会导致用电设备的绝缘损坏降低设备使用寿命, 当浪涌超过最大额定工作电压时, 紧凑型浪涌保护设备如压敏电阻、雪崩二极管等损坏。电压暂升波形见下图:

Hazards. Voltage swell may damage the insulation and reduce the life of electric equipment. It may also damage compact surge protection devices such as varistors and avalanche diodes when surge voltage exceeds the maximum rated operating voltage. The following figure illustrates the waveform of voltage swell:



调试方法 Debugging method:

1.投入"暂态电压"控制字

Enable the control of "Temporary voltage".

2.设置"电压暂降"为 90%, 此处 90%含义为 90%*标称电压,

Set the "Voltage dip" to be 90%. Meaning of 90% is 90%* Nominal voltage.

在电压输入端子上接入三相 50Hz 系统标称电压信号稳定 12s (用于判定系统带电稳定), 将电压低于 90%*标称电压, 并在 1min 内恢复正常。此时触发电压暂降功能, 装置弹出电压暂降事件记录并触发录波, 同时闭合对应继电器出口和点亮面板指示灯。电压暂降结束后按"RST"键可复归装置。

Supply the nominal voltage of a 3-phase 50Hz system to the voltage input terminal for 12s (to determine the running stability with electricity). Reduce the voltage below 90% of the nominal voltage and return to the normal voltage in 1min. It will trigger the function "Voltage dip". The "Voltage dip event" will generate and the waveform recorder will work. Meanwhile, the corresponding alarm output is closed and the lamp on the panel turns bright. Press RST to OFF this product after the voltage dip event.

6.8 电流、电压瞬态

6.8 Transient current and voltage

瞬态:指电压和(或)电流在稳态条件下的一次变化, 其持续时间小于数周期, 一般包括电压和(或)电流在稳态条件下突然发生的且具有单极性(主要为正或负)变化的非工频现象和电压和(或)电流在稳定状态下突然发生的且具有正负极性变化的非工频现象。

Transients. They are changes in voltage or current under steady conditions, lasting for a few cycles. In general, they include sudden and unipolar change (mainly positive or negative), or sudden and bipolar change (positive and negative) in voltage or current under steady conditions.

产生原因: 雷电或开关操作引起的瞬态过电压可能会引起各类设备故障或绝缘介质损坏。

Causes. Transient overvoltages caused by lightning or switching operations may make various equipment fail or damage the insulation.

危害: 瞬态过电压的高幅值和快速上升时间会引起像旋转电机、变压器、电容器、电缆、电流互感器、电压互感器和开关等电气设备的绝缘击穿。当瞬态通过电路引导进入半导体器件如集成电路时，易造成器件损坏。瞬态波形见下图：

Hazards. The high amplitude and rapid rise of transient overvoltage cause insulation breakdown in electrical equipment like rotating motors, transformers, capacitors, cables, current transformers, voltage transformers and switches. When circuits exposed to transients are led to semiconductor devices such as integrated circuits, it will damage electronic devices easily. The following figure illustrates the waveform of transients:



总部：安科瑞电气股份有限公司

Headquarter: Acrel Co., LTD.

地址：上海市嘉定区育绿路 253 号

Address: No.253 Yulv Road Jiading District, Shanghai, China

电话：0086-21-69158338 0086-21-69156052 0086-21-59156392 0086-21-69156971

TEL.: 0086-21-69158338 0086-21-69156052 0086-21-59156392 0086-21-69156971

传真：0086-21-69158303

Fax: 0086-21-69158303

网址：www.acrel-electric.com

Web-site: www.acrel-electric.com

邮箱：ACREL008@vip.163.com

Email: ACREL008@vip.163.com

邮编：201801

Postcode: 201801

生产基地：江苏安科瑞电器制造有限公司

Manufacturer: Jiangsu Acrel Electrical Manufacturing Co., LTD.

地址：江苏省江阴市南闸街道东盟工业园区东盟路 5 号

Address: No.5 Dongmeng Road,Dongmeng industrial Park, Nanzha Street,Jiangyin

City,Jiangsu Province,China

电话：0086-510-86179966

TEL: 0086-510-86179966

传真：0086-510-86179975

Fax: 0086-510-86179975

网址：www.jsacrel.com

Web-site: www.jsacrel.com

邮箱：sales@email.acrel.cn

Email: sales@email.acrel.cn

邮编：214405

Postcode: 214405