

ADL200-2DM Single Phase Prepaid Electronic Energy Meter

(Dormitory electricity management terminal)

Installation and operation instruction V1.0

Declare

The copyright is the property of Acrel. Any information in any paragraph or section cannot be extracted, copied or otherwise reproduced or propagated. Otherwise offenders shall take all consequences.

All rights are reserved.

Acrel reserves the right to modify the product specifications herein without notification. Please consult the local agent about the latest specifications before placing a purchase order.

Manual Revision Record

Date	older version	New version	revise content
20230217		V1.0	1..First version

Content

1 General.....	1
2 Function description.....	1
2.1 Main Function.....	1
2.2 Control Function.....	1
2.2.1 Prepaid Control.....	1
2.2.2 Time Control.....	1
2.2.3 Load management control.....	2
3 Technical parameter.....	3
4 External dimension (unit: mm).....	3
5 Wiring and installing.....	4
5.1 ADL200-2DM wiring diagram.....	4
5.2 Installation Precautions.....	4
6 Display and operation.....	4
6.1 Data Display.....	4
6.2 key operation.....	5
7 Communication protocol.....	5
8 Common fault diagnosis analysis and elimination method.....	5
8.1 Signal input failure.....	5
8.2 Communication failure.....	5

1 General

ADL200-2DM single-phase prepaid energy meter (dormitory electricity management terminal) is mainly used to measure single-phase AC electricity, suitable for student dormitory (apartment) electricity management. The terminal can have one live wire incoming and two live wires output in parallel. It can measure sockets and air-conditioning circuits separately, and can carry out pre-payment control. It can control the load and time of the two outgoing lines respectively, and supports nearly 30 tripping event record storage functions. Realize the commercialization of electricity, electricity safety and on-demand control of electricity management in school dormitories.

The dormitory power management terminal supports 485 communication, which can conveniently realize functions such as remote meter reading, remote recharge, and remote control. The measurement accuracy meets the requirements of GB/T17215.321-2008 standard.

2 Function description

2.1 Main Function

Function	Function Description
Measurement of kWh	Total power consumption and power consumption of each circuit
Measurement of electrical parameters	U、I
	P、Q、S、PF、F
LCD Display	8 bits section LCD display ,Background light
Key programming	4 keys programmable communication and other parameters
Pulse output	Active Pulse output
Multi-tariff and time	Support 4 time zones, 2 time slots, 14 daily time slots, 4 tariffs, 4 electricity prices
	Daily demand, monthly demand and occurrence time
	real-time demand
	Trip record, abnormal trip record
	date, time, week
Communication	RS485 Communication

2.2 Control Function

2.2.1 Prepaid Control

Dormitory electricity management terminal supports the prepaid function:

- Base amount can be set for students to use for free;
- Four levels of alarms can be performed on the remaining amount: insufficient balance alarm (level 1), pre-tripping alarm (level 2), arrears alarm (level 3), and credit reached limit alarm (level 4);
- The tripping mode of the pre-tripping alarm can be set to no tripping, automatic closing after tripping, and non-closing after tripping. After tripping, students can close the gate by pressing the button. When the credit limit is reached, the meter trips. At this time, only after paying the fee can continue to use electricity.

2.2.2 Time Control

Dormitory electricity management terminal supports time management control:

- Each circuit can be set to workday and holiday mode respectively;
- Up to 8 time periods can be set per day;
- Each time period can be set separately as closing state or night mode;
- During the closing time, the meter will be closed. During the night time, you can choose to trip directly or trip after the power is greater than the allowed power at night.

2.2.3 Load management control

Dormitory power management terminal supports rich load management control, and the specific working functions are as follows:

- Current upper limit: limit the maximum current of each branch, when the branch current exceeds the set value (<16A), the branch will trip.
- Total load power limit: Limit the maximum power consumption of each branch, and each branch can set different total power thresholds. When the branch power exceeds the set value, the branch will trip.
- Night power limit: It needs to be used together with time management control. In night mode, if the branch current exceeds the set value, the branch will trip
- Malicious load identification: limit branch access to undefined malignant loads, when the branch accesses unapproved malignant loads (mainly manifested as large power increments and large increment factors), the branch trips.
- Whitelist identification of malicious loads: Allow the defined malicious loads to use electricity normally (such as water dispensers, etc.).
- Air-conditioning mode: In the air-conditioning mode, the meter continuously detects the weak standby current of the air conditioner. Once there is an action to unplug the air conditioner socket, the meter will trip, and the power can only be switched on by contacting the management personnel.
- Intelligent power-limitation socket identification: support the identification of anti-power-limitation sockets. When a vicious load is connected to the circuit through the anti-power-limitation socket, the branch circuit will trip.
- Over-temperature control: When the temperature measured by the meter is higher than the set value for several consecutive times (the number of times can be set), the meter will trip.
- Over-voltage and under-voltage control: When the circuit voltage is higher or lower than the set value for several consecutive times (the number of times can be set), the meter will trip.
- The power consumption management terminal of the dormitory allows the automatic closing of the tripping action except the air-conditioning mode. Allowable times, trip waiting time can be set.

Note: Prepaid management control, time management control and load management control need to be used in conjunction with our company's prepaid electricity management system.

3 Technical parameter

Project		ADL200-2DM	
Measurement	Voltage	Reference voltage	220V
		Consumption	<10VA(Single Phase)
		Impedance	>2MΩ
		Accuracy class	Error±0.2%
	Current	Input current	0.2-0.5(30)A
		Output current	The maximum output current of each circuit is 16A
		Consumption	<4VA(Single Circuit Rated Current)
		Accuracy class	Error±0.2%
	Power		Active power, reactive power, apparent power, error ±0.5%
Frequency		45~65Hz, Error±0.2%	
Size	Pole	2.5P	
Metering	Energy	Active energy(Accuracy class: 0.5)	
Digital signal	Energy pulse output	1 active photocoupler output	
Pulse	Width of pulse	80±20ms	
	Pulse constant	1600imp/kWh	
Communication	Interface and communication protocol	RS485 □: Modbus RTU	
	Range of communication address	Modbus RTU:1~ 247	
	Baud rate	Support 1200bps~9600bps	
environment	Operating temperature	-25°C~+55°C	
	Storage temperature	-40°C~+70°C	
	Relative humidity	≤95% (No condensation)	
	Altitude	<2000m	

4 External dimension (unit: mm)

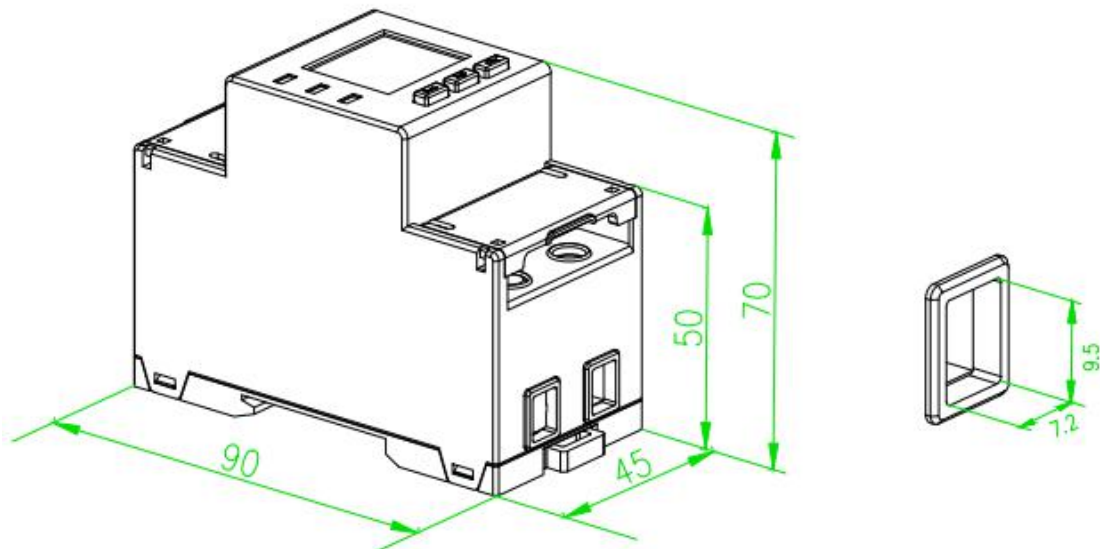

Figure 1 External dimensions of ADL200-2DM

Note: The wiring torque for direct connection should not be greater than 2.0N·m;

5 Wiring and installing

5.1 ADL200-2DM wiring diagram

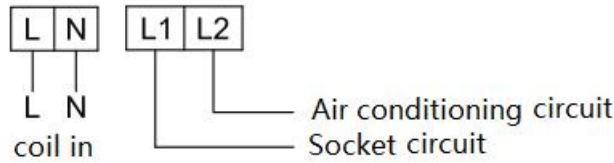

Figure 2 ADL200-2DM wiring diagram

Note: When wiring, the corresponding load should be connected as shown in the wiring diagram. The L1 and L2 loop access loads are consistent with the requirements of the wiring diagram to facilitate system management.

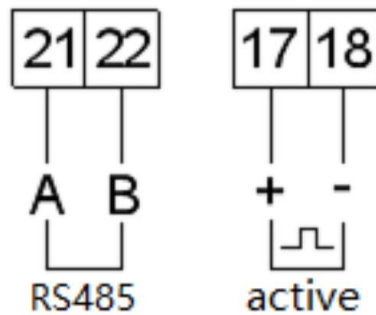

Figure 3 ADL200-2DM Auxiliary Terminal Diagram

5.2 Installation Precautions



The energy meter should be installed in a ventilated and dry place indoors, using 35mm standard Din rails. When installing the wiring, it should be connected according to the wiring diagram on the side of the electric energy meter, and it is best to use a copper terminal to connect.

6 Display and operation

6.1 Data Display

The dormitory power consumption management terminal supports automatic rotation display and button rotation display.

Under normal circumstances, the energy meter enters the wheel display mode after being powered on, and the wheel display data includes the remaining basic amount, remaining amount, total power consumption, L1 power consumption, and L2 power consumption.

Button switching is divided into voltage current, power and electric energy amount display, which can be switched by pressing ,  and  respectively.

 key to turn the page is as follows:

Voltage, total current, L1 current, L2 current, address, baud rate, check digit, time (year, month, day, week), time (hour, minute, second), version number, full display.

key to turn the page is as follows:

Total active power, L1 active power, L2 active power, total reactive power, L1 reactive power, L2 reactive power, total apparent power, L1 apparent power, L2 apparent power, total power factor, L1 power factor, L2 power factor.

key to turn the page is as follows:

Remaining basic amount, remaining amount, total power consumption, L1 power consumption, L2 power consumption, alarm amount 1, alarm amount 2, electricity price, credit amount.

6.2 key operation

The dormitory power consumption management terminal supports three-button programming operation (can be turned off at the factory), which can be used to set communication parameters (including meter MODBUS protocol communication address, baud rate, check digit) and system parameters (including backlight time, programming password and strong control parameters, etc.).

7 Communication protocol

The communication interface of the dormitory power consumption management terminal instrument supports the MODBUS-RTU protocol. The baud rate of the communication port can be set between 1200bps, 2400 bps, 4800 bps, 9600bps, 19200 and 38400bps. The parity bit can be set to no parity, odd parity or even parity. MODBUS-RTU protocol supports 03 function code and 10 function code.

The relevant register address table can be obtained by contacting the manufacturer, and no explanation is given here;

The agreements related to prepaid management control, time management control and load management control are not explained here, if necessary, please contact the manufacturer to obtain them.

8 Common fault diagnosis analysis and elimination method

8.1 Signal input failure

Fault performance: After the meter is powered on, the displayed power or the count of electric energy is not accurate.

Troubleshooting: switch the display interface of the meter to the power (active power P, power factor PF) interface, check whether the power display is negative and whether the power factor is between 0.60-0.95, and then check whether the current signal line input and output lines are reversed (That is, the incoming line of the current must be consistent with the incoming line end of the instrument), which is consistent with the wiring diagram on the instrument.

8.2 Communication failure

Fault performance: After the instrument is powered on, it cannot communicate with the host computer normally.

Troubleshooting: 1. The voltage value between the communication output A and B of the measuring instrument should be between +(4.0-5.0)V;

Check whether the communication wiring method is correctly wired according to the wiring diagram (that is, the communication terminal A/B of the instrument should correspond to the communication serial port A/B);

The issuance of control commands is not detailed in the manual due to the space. If necessary, please contact our customer service.

Headquarters: Acrel Co., LTD.

Address: No.253 Yulv Road Jiading District, Shanghai, China

TEL.: 0086-21-69158338 0086-21-69156052 0086-21-59156392 0086-21-69156971

Fax: 0086-21-69158303

Web-site: www.acrel-electric.com

E-mail: ACREL008@vip.163.com

Postcode: 201801

Manufacturer: Jiangsu Acrel Electrical Manufacturing Co., LTD.

Address: No.5 Dongmeng Road,Dongmeng industrial Park, Nanzha Street,Jiangyin City,Jiangsu Province,China

TEL: 0086-510-86179966

Fax: 0086-510-86179975

Web-site: www.jsacrel.com

Postcode: 214405

E-mail: sales@email.acrel.cn