

DDSY1352
Single phase prepaid watt hour meter
(Dormitory power management terminal)
Installation manual V1.0

State

All rights reserved. Without the written permission of the company, any paragraphs and chapters in this manual should not be excerpted, copied or reproduced or disseminated in any form, otherwise all consequences should be borne by the offender.

The company reserves all legal rights.

The company reserves the right to modify the product specifications described in this manual without notice. Before placing an order, please consult your local agent for the current specifications of this product.

Manual revision record:

Date	Old version	New version	Remark
20200911		V1.0	Add

Contents

1 General.....	1
2 Model description.....	1
3 Instrument function.....	1
4 Technical parameter.....	3
5 Dimension drawings (unit: mm)	4
6 wiring and installing.....	5
7 Display and operation.....	6
8 Communication protocol requirements.....	7
9 Analysls and solutions of common failures	8

1 General

DDSY1352 Single phase prepaid watt hour meter (Dormitory power management terminal) is mainly used to measure single-phase AC power consumption and it is suitable for power consumption management of student dormitory (apartment). The terminal can have one live wire incoming and multiple live wires output in parallel, with three, four and five options, and can measure lighting, socket, air conditioning circuit, toilet, water heater, etc. respectively; It can carry out prepayment control, load control and time control for each outgoing line respectively, and support the storage function of nearly 30 tripping event records, so as to realize the power commercialization, power safety and on-demand control of school dormitory power management.

The dormitory power management terminal supports 485 and infrared communication, which can easily realize the functions of remote meter reading, remote recharge, remote control and so on. The measurement accuracy meets the requirements of GB / T17215.321-2008.

2 Model description

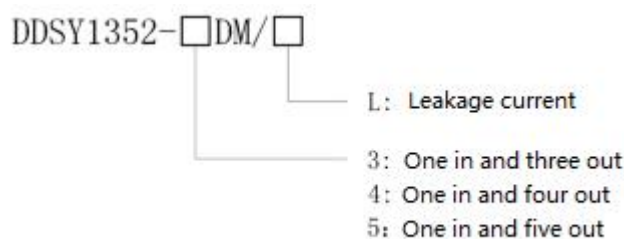

Notes: Leakage current monitoring is an optional function, which is not optional when one in and three out

3 Instrument function

3.1 main function

Function	Function description
Electric energy metering	Total power consumption and power consumption of each circuit
Measurement of electrical parameters	U、I
	P、Q、S、PF、F
LCD display	8-bit Segment LCD display and backlight
Key	4 key programmable communication and other

programming	parameters
Pulse output	Active pulse output
Compound rate And time	Support 4 time zones, 2 time period tables 14 day periods, 4 rates and 4 electricity prices
	Daily demand, monthly demand and occurrence time
	Real time demand
	Trip record and abnormal trip record
	Date, time, week
Communication	Infrared communication
	RS485 communication

3.2 Control function

3.2.1 Prepayment control

The dormitory power management terminal supports the prepayment function:

- The basic amount can be set for free use by students;
- Four levels of alarm can be given to the remaining amount: insufficient balance alarm (level I), pre trip alarm (Level II), arrears alarm (level III) and reaching the upper limit of credit alarm (level IV);
- Each level of alarm will cause the backlight of the meter to be always on. The tripping mode of pre trip alarm can be set as no tripping, automatic closing after tripping and no closing after tripping. After tripping, students can switch on by pressing the key. After reaching the upper limit of credit, the meter will trip. At this time, power transmission can be continued only after payment.

3.2.2 Time control

The dormitory power management terminal supports time management control:

- Each circuit can be set to working day and holiday mode respectively;
- Up to 8 time periods can be set every day;
- Each time period can be set to closing state or night mode respectively;
- During the closing time period, the meter remains closed. During the night time period, you can choose to trip directly or after it is greater than the allowable power at night.

3.2.3 Load management control

The dormitory power management terminal supports rich load management control, and the specific working functions are as follows:

- Upper current limit: limit the maximum current of each branch. When the branch current exceeds the set value (< 16A), the branch trips.
- Load total power limit: limit the maximum power consumption of each

branch, and each branch can set different total power thresholds. When the branch power exceeds the set value, the branch trips.

- Night power limit: it needs to be used together with time management control. In night mode, when the branch current exceeds the set value, the branch trips.
- Identification of malignant load: restrict branch access to undefined malignant load. When branch access to unauthorized malignant load (mainly represented by large power increment and large increment factor), branch trips.
- White list identification of malignant load: allow the defined malignant load to use electricity normally (such as water dispenser, etc.).
- Air conditioning mode: in the air conditioning mode, the electricity meter continuously detects the weak standby current of the air conditioner, but once there is the action of unplugging the air conditioner socket, the electricity meter will trip, and the power can only be switched on and transmitted by contacting the management personnel.
- Identification of intelligent power limiting socket: it supports the identification of anti power limiting socket. When malignant load is connected to the circuit through the anti power limiting socket, the branch trips.
- Overtemperature control: when the measured temperature of the meter is higher than the set value for several consecutive times (the times can be set), the meter trips.
- Overvoltage and undervoltage control: when the circuit voltage is higher or lower than the set value for several consecutive times (times can be set), the meter trips.
- The dormitory power management terminal allows automatic closing of tripping actions other than air conditioning mode. Allowable times and tripping waiting time can be set.

Notes: Prepayment management control, time management control and load management control should be used in conjunction with the prepayment power management system of the company.

4 Technical parameter

Project			DDSY1352-3DM	DDSY1352-4DM (5DM)
Measure	Voltage	Reference voltage	220V	220V
		Consumption	<10VA(single-phase)	<10VA(single-phase)
		Impedance	>2MΩ	>1.5MΩ
		Accuracy class	Error ± 0.2%	Error ± 0.2%
	Current	Input current	5(40)A	10(60)A

	Output current	Maximum output current of each circuit 16A	Maximum output current of each circuit 16A
	Consumption	<4VA(Single circuit rated current)	<4VA(Single circuit rated current)
	Accuracy class	Error $\pm 0.2\%$	Error $\pm 0.2\%$
	Power	Active power, reactive power, apparent power, error $\pm 0.5\%$	Active power, reactive power, apparent power, error $\pm 0.5\%$
	frequency	45~65Hz, Error $\pm 0.2\%$	45~65Hz, Error $\pm 0.2\%$
Metering	Electric energy	1 Class	1 Class
Digital signal	Electric quantity pulse output	1 active optocoupler output	1 active optocoupler output
Pulse	Pulse width	80 \pm 20ms	80 \pm 20ms
	Pulse constant	3200imp/kWh	1600imp/kWh
Signal communication	Interface and communication protocol	RS485 Interface: Modbus RTU	RS485 Interface: Modbus RTU
	Correspondence address range	Modbus RTU:1~ 247	Modbus RTU:1~ 247
	Baud rate	Support 1200bps~9600bps	Support 1200bps~9600bps
Environment	Working temperature	-25 $^{\circ}$ C~+55 $^{\circ}$ C	-25 $^{\circ}$ C~+55 $^{\circ}$ C
	Storage temperature	-40 $^{\circ}$ C~+70 $^{\circ}$ C	-40 $^{\circ}$ C~+70 $^{\circ}$ C
	Relative humidity	$\leq 95\%$ (No condensation)	$\leq 95\%$ (No condensation)
	Altitude	<2000m	<2000m

5 Dimension drawings (unit: mm)

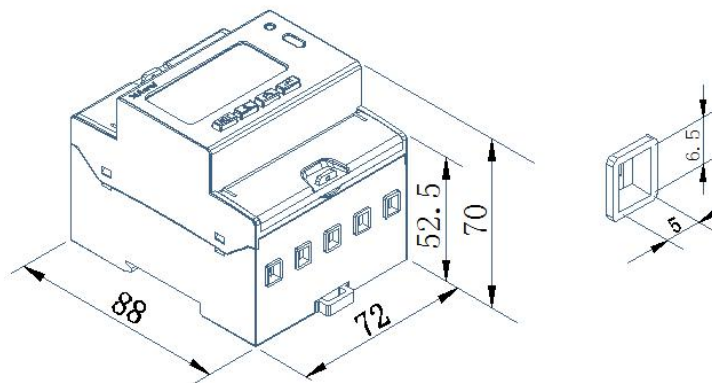

DDSY1352-3DM

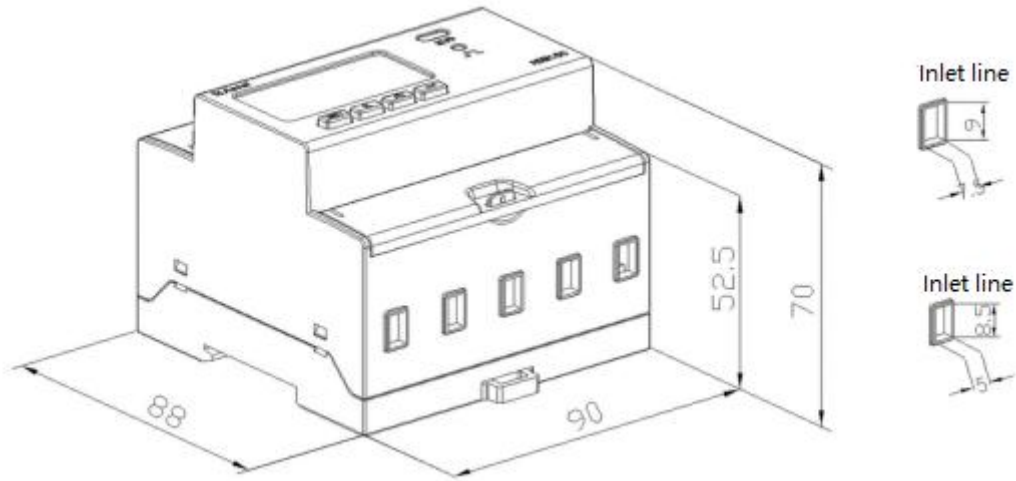

DDSY1352-4DM(5DM)

Notes: The torque of direct connect should not be greater than 2.0N·m;

6 Wiring and installing

6.1 DDSY1352-3DM Wiring diagram

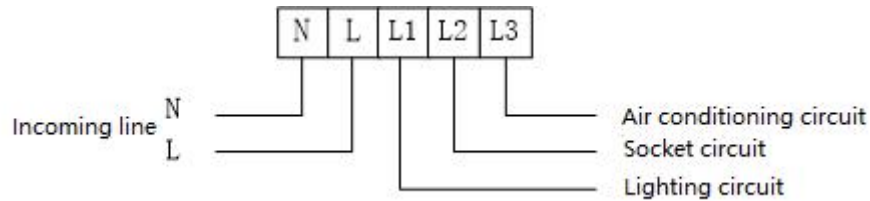

DDSY1352-3DM Wiring diagram

Notes: During wiring, the corresponding load should be connected according to the wiring diagram. The access load of L1, L2 and L3 circuits should be consistent with the requirements of the wiring diagram to facilitate system management.

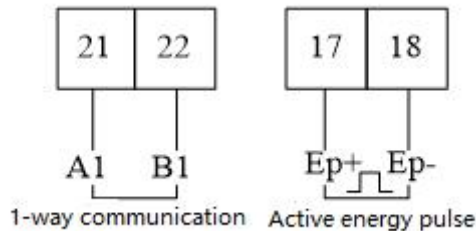

DDSY1352-3DM Auxiliary terminal diagram

6.2 DDSY1352-4DM(5DM) Wiring diagram

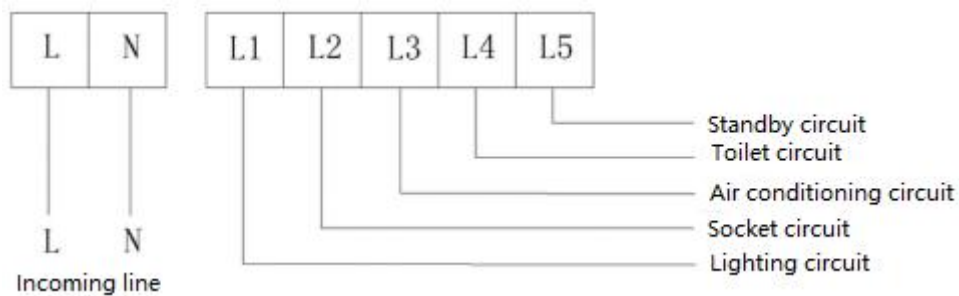

DDSY1352-4DM(5DM) Wiring diagram

Notes: During wiring, the corresponding load should be connected according to the wiring diagram. The access load of L1, L2, L3, L4 and L5 circuits should be consistent with the requirements of the wiring diagram for system management.

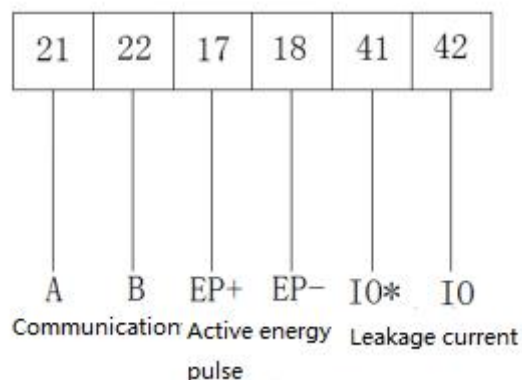

DDSY1352-4DM(5DM) Auxiliary terminal diagram

6.3 Installation precautions

The electric energy meter should be installed in a ventilated and dry place indoors and installed with 35mm standard guide rail. When installing the wiring, the wiring should be carried out according to the wiring diagram on the side of the electric energy meter, preferably connected with a copper wire terminal.



7 Display and operation

7.1 Data display

The dormitory power management terminal supports automatic rotation display and key rotation display.

Under normal circumstances, after the electric energy meter is powered on, it enters the rotation display mode. The rotation display data includes the remaining

basic amount, remaining amount, total power consumption, L1 power consumption, L2 power consumption, L3 power consumption, L4 power consumption and L5 power consumption.

Key switching is divided into electrical parameter and prepaid parameter display, You can switch by pressing  and  respectively.  Key page turning contents are as follows::

Voltage, total current, L1 current, L2 current, L3 current, L4 current, L5 current, total active power, L1 active power, L2 active power, L3 active power, L4 active power, L5 active power, total reactive power, L1 reactive power, L2 reactive power, L3 reactive power, L4 reactive power, L5 reactive power, total apparent power, L1 apparent power, l

Key page turning contents are as follows:

Remaining basic amount, remaining amount, total power consumption, L1 power consumption, L2 power consumption, L3 power consumption, L4 power consumption, L5 power consumption, L1 temperature, L2 temperature, L3 temperature, L4 temperature, L5 temperature, leakage current, alarm amount 1, alarm amount 2, electricity price, credit amount, address, baud rate, check bit, time (month, day, week), time (hour, minute and second), version

Notes: DDSY1352-3DM has no L4 and L5 related parameters, only has one internal temperature, no leakage current.

7.2 Key operation

The dormitory power management terminal supports four key programming operation (it can be closed after leaving the factory), and can be used to set communication parameters (including meter Modbus protocol communication address, baud rate and check bit) and system parameters (including backlight time, programming password and strong control parameters, leakage flow ratio, leakage current switch, etc.).

8 Communication protocol requirements

The instrument communication interface of dormitory power management terminal supports MODBUS-RTU protocol. The baud rate of communication port can be set between 1200BPS, 2400bps, 4800 BPs, 9600bps, 19200 and 38400bps. The check bit can be set to no check, odd check or even check. MODBUS-RTU protocol supports 03 functions

The relevant register address table can be obtained by contacting the manufacturer, which is not described here;

Agreements related to prepayment management control, time management control and load management control are not described here. If necessary, please contact the manufacturer.

9 Analysls and solutions of common failures

9.1 Signal input failure

Fault performance: After the instrument is powered on, the displayed power or electric energy count is inaccurate.

Solution: Switch the instrument display interface to the power (active power P, power factor PF) interface, check whether the power display is negative and whether the power factor is between 0.60-0.95, and then check whether the incoming and outgoing lines of the current signal line are connected reversely (i.e. the incoming line of the current must be consistent with the incoming end of the instrument), which is consistent with the wiring diagram on the instrument.

9.2 Communication failure

Fault performance : The instrument cannot communicate with the upper computer normally after being powered on.

Solution: 1. The voltage value between the communication outputs a and B of the measuring instrument should be + (4.0-5.0) V;

2. Check whether the communication wiring mode is correctly wired according to the requirements of the wiring diagram (that is, the communication terminal A / b of the instrument should correspond to the communication serial port A / b);

Headquarters: Acrel Co., LTD.

Address: No.253 Yulv Road Jiading District, Shanghai, China

TEL.:0086-21-69158338 0086-21-69156052 0086-21-59156392 0086-21-69156971

Fax: 0086-21-69158303

Web-site: www.acrel-electric.com

E-mail: ACREL008@vip.163.com

Postcode: 201801

Manufacturer: Jiangsu Acrel Electrical Manufacturing Co., LTD.

Address: No.5 Dongmeng Road,Dongmeng industrial Park, Nanzha Street,Jiangyin
City,Jiangsu Province,China

TEL./Fax: 0086-510-86179970

Web-site: www.jsacrel.com

Postcode: 214405

E-mail: JY-ACREL001@vip.163.com