

ADL100 -EY/ADL300-EY

Operation Manual of wireless prepaid watt-hour meter

Installation and operation instruction V1.0

Declare

The copyright is the property of Acrel. Any information in any paragraph or section cannot be extracted, copied or otherwise reproduced or propagated. Otherwise offenders shall take all consequences.

All rights are reserved.

Acrel reserves the right to modify the product specifications herein without notification. Please consult the local agent about the latest specifications before placing a purchase order.

Record of amendments to specifications

Date	The old version	New Edition	Modify the content
2022/4/10	V1.0		

Content

1 General	1
2 Type description	1
3 Instrument function	1
3.1 Main function	1
3.2 Control function	2
4 Technical parameter	2
4.1 Electrical characteristics	2
5 Dimension drawings (Unit: mm)	4
6 Wiring and installing	6
7 Operation and display	7
8 Communication protocol requirements	9

1 General

ADL100-EY single phase wireless prepaid watt-hour meter, ADL300-EY three phase wireless prepaid watt-hour meter are used for calculating the single and three phase active energy respectively on the frequency of 50 Hz. The meter has functions of pre-paid, load controlling, time control and NB, 2G, 4G, Wifi, RS485 communication etc. Products meet the Enterprise Standard Q31/0114000129C039-2019 《Enterprise Standard for electronic prepayment watt-hour meter》 requirements.

2 Type description

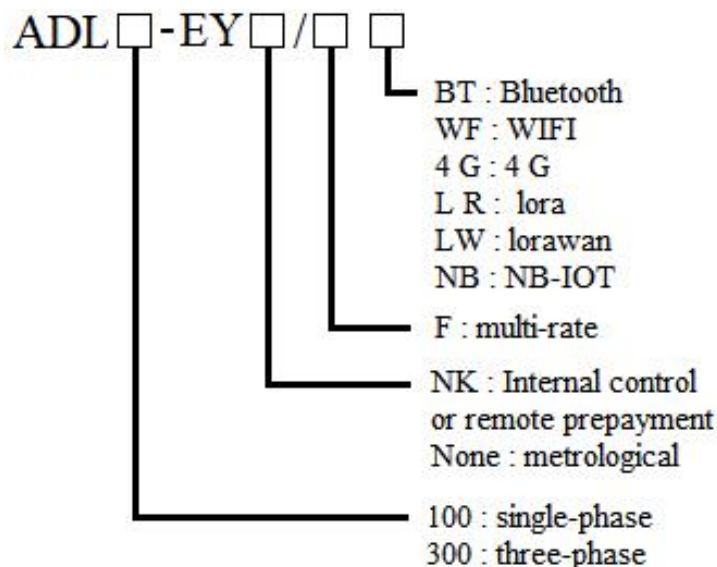

3 Instrument function

3.1 Main function

Function name	Function description	ADL100-EY	ADL300-EY
Measurement of kWh	Active kWh (positive and negative)	■	■
	A, B, C phase positive active kWh		■
Measurement of electrical parameter	U、I P、Q、S、PF、F	■	■
LCD Display	8 bits section LCD display, background light	■	■
Key programming	4 keys to communication and set parameters	■	■
Pulse output	Active pulse output	■	■
LED alarm	TRIP alarm	■	■
Multi-tariff and functions	Adapt 4 time zones, 4 time interval lists, 14 time interval by day and 4 tariff rates	□	□
	Max demanded kWh and time happened	□	□

	Real time demanded	<input type="checkbox"/>	<input type="checkbox"/>
	Historical freeze, power purchases	<input type="checkbox"/>	<input type="checkbox"/>
	Date, time, week	<input type="checkbox"/>	<input type="checkbox"/>
communication	Infrared communication	<input type="checkbox"/>	<input checked="" type="checkbox"/>
	The second communication path: Communication interface: RS485, Communication protocol: Modbus-RTU	<input checked="" type="checkbox"/>	<input checked="" type="checkbox"/>
	4G Communication	<input type="checkbox"/>	<input type="checkbox"/>
	Wifi/ Bluetooth Communication	<input type="checkbox"/>	<input type="checkbox"/>
	Lorawan Communication	<input type="checkbox"/>	<input type="checkbox"/>
	NB Communication	<input type="checkbox"/>	<input type="checkbox"/>
	Prepaid control	<input checked="" type="checkbox"/>	<input checked="" type="checkbox"/>
Prepayment agreement (remote)	Time control	<input checked="" type="checkbox"/>	<input checked="" type="checkbox"/>
	Load control	<input checked="" type="checkbox"/>	<input checked="" type="checkbox"/>
	Forced control	<input checked="" type="checkbox"/>	<input checked="" type="checkbox"/>

(“■” means standard, “□” means optional)

Note: prepaid function should be used with the company’s prepaid sales management system.

3.2 Control function

3.2.1 Prepaid control

Instrument support pre-payment function. Can set the basic amount of electricity meter free trial; Can carry on four levels alarm to the remaining amount: insufficient balance alarm (first level) , pre-trip alarm (second level) , arrearage alarm (third level) , reach the credit limit (fourth level) alarm.

3.2.2 Time Management Control

Instrumentation support time management control. The day can be set to working day or holiday mode, up to a maximum of 8 time periods per day, each time period can be set to turn-on or turn-off state.

3.2.3 Load Management Control

Instrument Support Load Management Control, specific functions as follows:

Load total power limit: limit the maximum power consumption of the branch, when the branch power exceeds the set value, the branch trip.

Malignant load identification: limit the branch access to the undefined malignant load, when the branch access to the unauthorized malignant load (mainly manifested as a large power increment and a large increment factor) , the branch trip.

4 Technical parameter

4.1 Electrical characteristics

Projects	DDSY1352	DTSY1352
Specification		

Measurement	voltage	Reference voltage	220V	3×220/380V	
		Consumption	<10VA(Single phase)		
		Impedance	>2MΩ		
		Accuracy class	Error±0.2%		
	current	Input current	10(60)A	3×1(6)A, 3×10(80)A	
		Consumption	<4VA(Single phase rated current)		
		Accuracy class	Error±0.2%		
	Power		Active, reactive, apparent power, error±0.5%		
Frequency		45~65Hz, Error±0.2%			
meter-amount	Energy		Active energy (Accuracy class:1)	Active energy (Accuracy class:0.5)	
	Clock		≤0.5s/d		
number-signal	Energy pulse output		1 active optocoupler output		
	Switching output		1 Switching output	2 Switching output	
pulse	Width of pulse		80±20ms		
	Pulse constant		1600imp/kWh	6400imp/kWh,400imp/kWh	
communicaton	RS485	Interface and communication		RS485: Modbus RTU	
		Range of communication address		Modbus RTU:1~247	
		Baud rate		Support 1200bps~19200bps	
	Lorawan	Working band		GSM 850, EGSM 900, DCS 1800, PCS 1900	
		Transmission rate		Maximum rate of descent 85.6kbps, Maximum uplink speed 85.6kbps	
	4G	Working band		GSM 990/1800 MHZ LTE-FDD B1/B3/B5/B8 LTE-TDD B34/B38/B39/B40/B41	
		Transmission rate		The maximum downlink rate is 10Mbps and the maximum uplink rate is 5mbps	
	NB	Transmission rate		H-FDD B1 B3 B8 B5 B20	
		Transmission rate		Maximum rate of descent 25.2Kbps, Maximum uplink speed 15.62 Kbps	
	Environment	Relative temperature			-25°C~+55°C
Storage temperature			-40°C~+70°C		
Relative humidity			≤95%(No condensation)		
Altitude			<2000m		

5 Dimension drawings (Unit: mm)

ADL100-EY

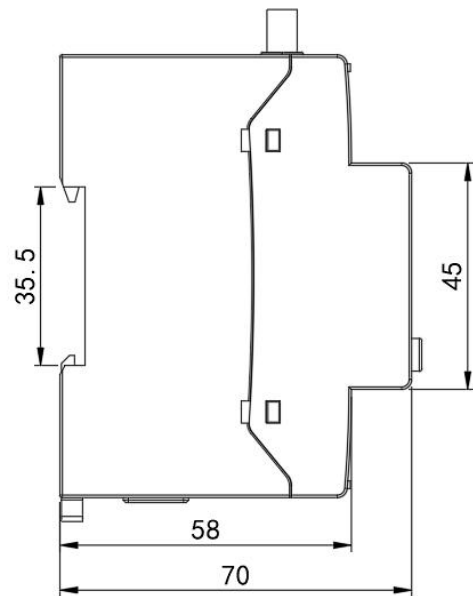
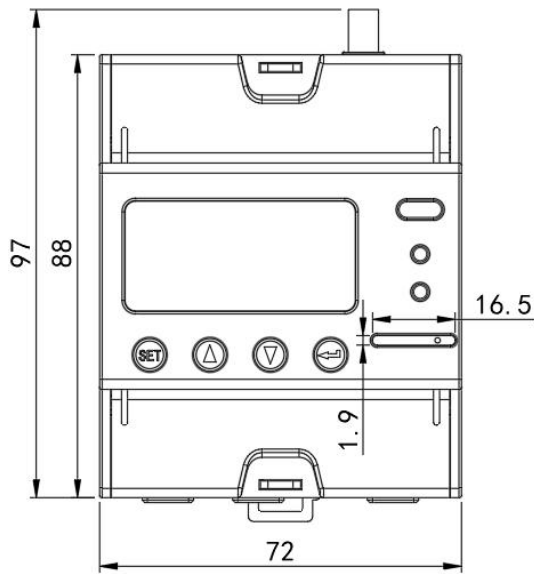
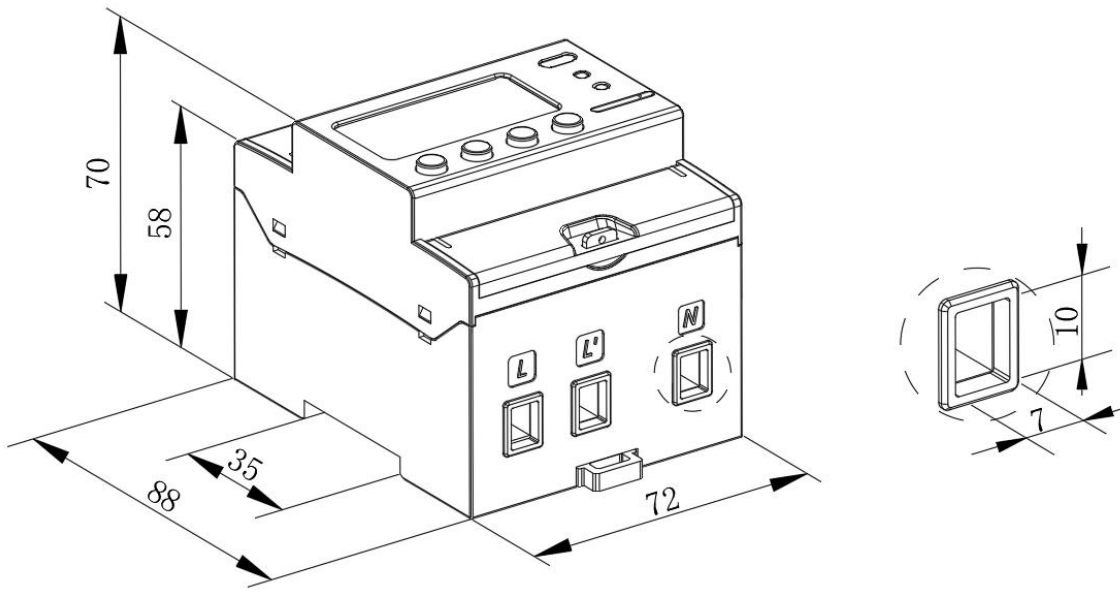

direct connect

ADL300-EY

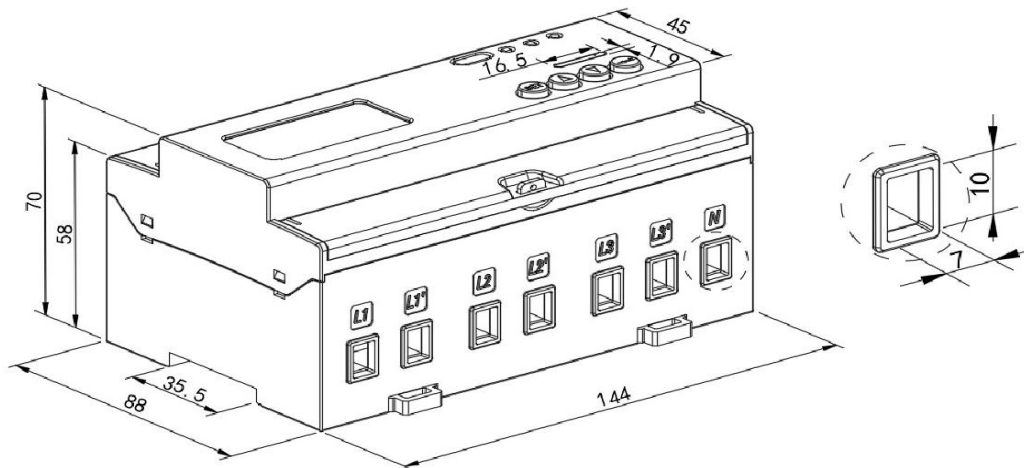

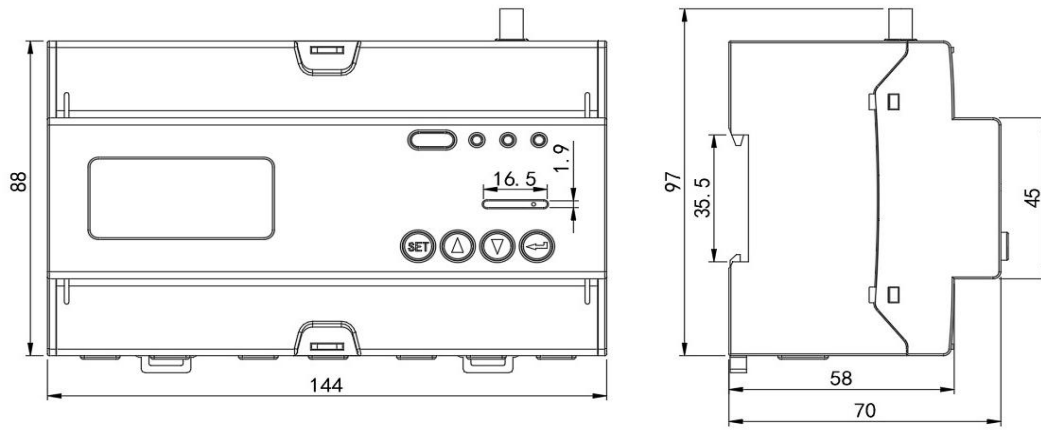

direct connect

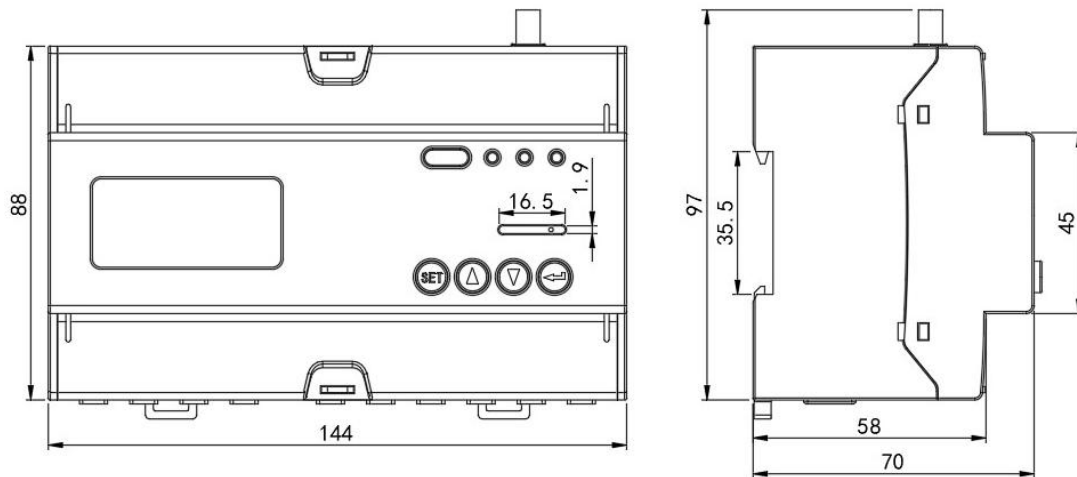
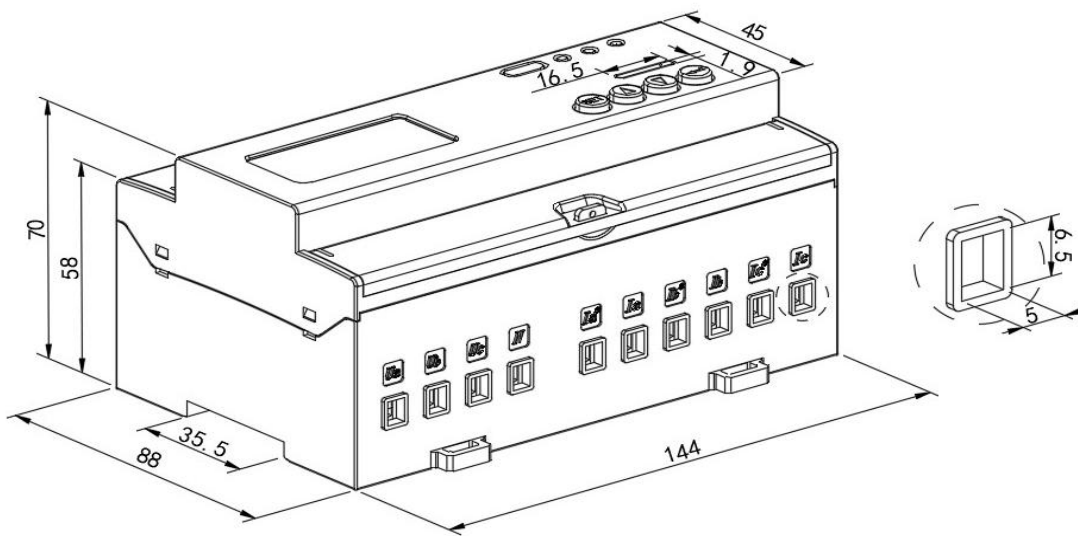

connect via CT

Note: The torque of direct connect should not be greater than $4.0\text{N}\cdot\text{m}$, and the torque of connect via CT should not be greater than $2.0\text{N}\cdot\text{m}$.

6 Wiring and installing

Wiring sample of voltage and current

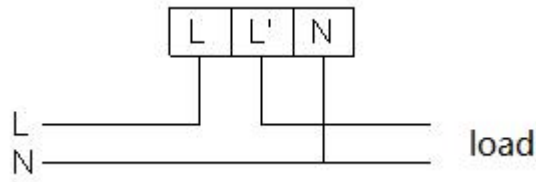

ADL100-EY

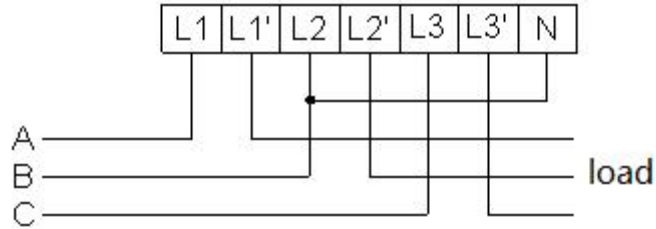

ADL300-EY

Three phase three lines direct connect

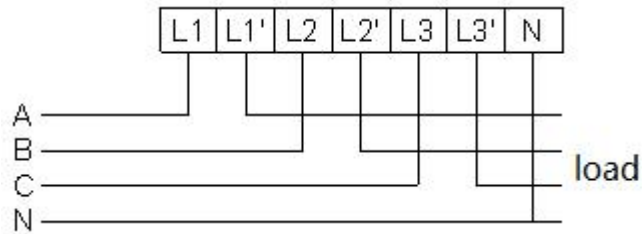

ADL300-EY

Three phase four lines direct connect

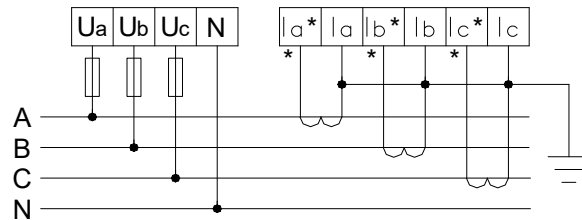

ADL300-EY

Three phase four lines connect via CT

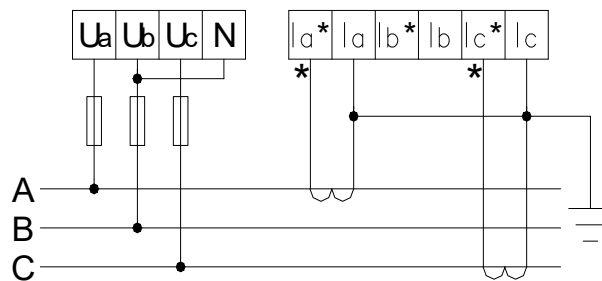

ADL300-EY

Three phase three lines connect via CT

Wiring Diagram of auxiliary function

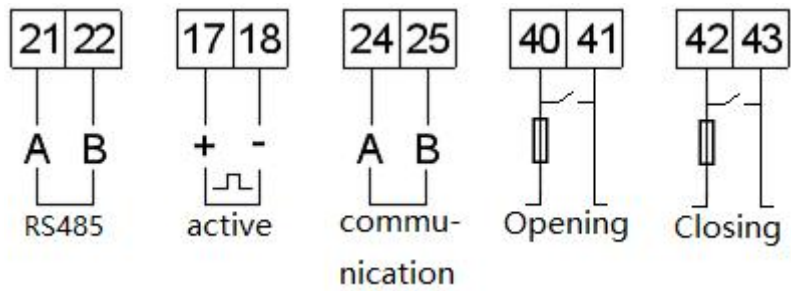

Note: 1. When the instrument band internal control function, (40-41) , (42-43) default can not be used. If need to use, need the customer to indicate in the order form.

When tripping, a voltage should be introduced to 40 and 41 connected to the control terminal of the corresponding circuit breaker.

The closing terminals of 42 and 43 can be used to control the closing of a specific device such as an electric operating mechanism.

Terminals 41 and 43 shall be connected to fuses with a voltage rating greater than the current voltage level of the system and rated current of 3-5A.

7 Operation and display

7.1 display

Under normal circumstances, the watt-hour meter after the default display the remaining amount



Residual amount



Total energy consumption

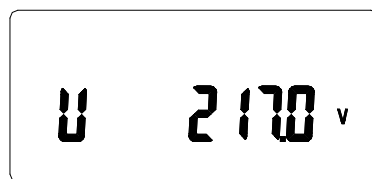

Voltage display



Current display



Current price



Total electricity purchases







7.2 Display the switch operation

Three types of view key can be achieved through the screen display. The order of the various display interfaces is illustrated as follows:

 : Voltage, current, active power, apparent power, frequency, power factor, date, time, address, version number, full display detection

 : Total power consumption, peak power consumption, average power consumption, valley power consumption, meter number, alarm amount 1, alarm amount 2, current electricity price, times of power purchase, power threshold

7.3 Keystroke programming

Under any display in the measurement display menu, Press  to display "0000" and prompt for a password (the default is 0001) before pressing . If the password is entered incorrectly, the initial in  is returned; if the password is entered correctly, the parameters can . When you're done, press , Go to the "SAVE" screen and press  "YES" or "NO". Save and exit if pressed under "Yes" and quit if pressed under "NO".

The programming menu is listed below:

Num	First menu		Second menu		
	Symbol	Mean	Symbol	Mean	Range
1	BUS	Communication settings	ADDR	Address setting	1-247
			BAUD	Baud rate	38400、19200、9600、4800、2400、1200
			PARITY	Parity	None、 Even
2	SYS	System settings	PL	Network	3 phase 4 lines 3 phase 3 lines
			ENCRYPT	Encryption settings	ON OFF
			EF.E	Multi-tariff rate	F:Multi-tariff rate E:No multi-tariff rate
			CODE	Code setting	0-9999
			MANUAL	Remote control	ON OFF
			PMAX	Power threshold setting	Unit:W
			LED	Time of light	Unit: min
			IP	IP address setting	
			PORT	Port ID	
3	IN	Input settings	PT	Voltage ratio setting	1-9999
			CT	Current ratio setting	1-9999
4	OUT	Output selection	0-LEVEL 1-PULSE	Relay control mode	0:Level output 1:Pulse output

8 Communication protocol requirements

Instrument communication interface support, The baud rate of communication port can be set between 1200BPS, 2400bps, 4800bps, 9600bps, 19200bps and 38400bps, The check bit can be set to no check or even check.

8.1 MODBUS protocol communication address table

ADL100-EY communication address table

Address	Variable	Data type	R/W	Notes
0000H	Current total electricity	UINT32	R	Calculation factor 0.01 Unit kWh
0002H	Current spike electric energy	UINT32	R	
0004H	Current peak electric energy	UINT32	R	
0006H	Current flat electric energy	UINT32	R	
0008H	Current valley electric energy	UINT32	R	
000AH	code	UINT16	R/W	Effective range (0~9999)
000BH	U Voltage	UINT16	R	Calculation factor 0.1, unit: V
000CH	I current	UINT16	R	Calculation factor 0.01, unit:A
000DH	P Active power	INT16	R	Calculation factor 0.001, Unit:kW
000FH	S Apparent power	UINT16	R	Calculation factor 0.001, unit: kVA
0010H	PF Ppower factor	INT16	R	Calculation factor 0.001 Effective range (-1000~1000)
0011H	Frequency	UINT16	R	Calculation factor 0.01, unit:Hz
0012H	Year, month	UINT8×2	R/W	
0013H	Day, hour	UINT8×2	R/W	
0014H	Minute, second	UINT8×2	R/W	
0015H-003BH	Reserved			
003CH	Current forward active total electric energy	UINT32	R	Calculation factor 0.01 Unit kWh
003EH	Current reversing active total electric energy	UINT32	R	
0046H	Alarm amount 1	INT32	R/W	Calculation factor0.01 unit yuan
0048H	Alarm amount 2	INT32	R/W	
004AH	Credit amount	UINT32	R/W	
004CH	New purchase amount	INT32	R	
004EH	Times of power purchase	UINT16	R	(0~1000)
004FH	Remaining amount	INT32	R	Calculation factor 0.01 Unit yuan
0051H	Total purchase amount	INT32	R	
0053H-0056H	Reserved			
0057H	Mandatory control word	UINT16	R/W	0001: Forced control on 0000: Forced closure
0058H	On off control word	UINT16	R/W	0000: Forced closing 0001: Forced trip
0059H-0060H	Peak and valley electricity price	UINT32×4	R/W	Calculation factor 0.0001 Unit yuan
0061H	Current threshold	UINT16	R/W	Unit W
0062H	Operation status word	UINT16	R/W	
0063H	Output mode	UINT16	R/W	0000: Level output

				0001: Pulse output
0064H-035FH	Reserved			
0360H	Main communication: Communication address and baud rate	UINT8×2	R/W	Communication address: 1~247 Baud rate: 0:1200 1:2400 2:4800 3:9600 4:19200 5:38400
0361H	Check bit stop bit	UINT8×2	R/W	Check bit: 0: No check 1: Odd check 2: Even check Stop bit: 0:11 stop bit 1:1.51 stop bit 2:21 stop bit
0362H-0364H	Reserved			
0365H-1FFFH				
2000H	First time zone address First time zone start data:day First time zone start data:month Fourth time zone address Fourth time zone start data:day Fourth time zone start data:month	UINT8×12	R/W	Time table number: 01 Corresponds to the first set 02 Corresponds to the second set
2006H	The first time table: Rate no. of period 1 Start time of the first period: minutes Start time of the first period: hour Period 14 rate No Starting time of the 14th period: minutes Starting time of the 14th period: hour	UINT8×42	R/W	Rate Number: 01 for Pointy 02 for peaks 03 for Ping 04 for Valley
201BH	Second time table: Rate no. of period 1 Start time of the first period: minutes Start time of the first period: hour Period 14 rate No	UINT8×42	R/W	Rate Number: 01 for Pointy 02 for peaks 03 for Ping 04 for Valley

	Starting time of the 14th period: minutes Starting time of the 14th period: hour			
--	---	--	--	--

ADL300-EY

Starting address	Data item name	length	Read / write	remarks
0000H	Current total electricity	UINT32	R	Calculating factor:0.01 unit:kWh
0002H	Current spike electric energy	UINT32	R	
0004H	Current peak electric energy	UINT32	R	
0006H	Current flat electric energy	UINT32	R	
0008H	Current valley electric energy	UINT32	R	
000AH-000CH	Date, time	UINT8×6	R/W	Seconds, minutes, days, years
000DH-0027H	Reserved			
0028H	First time zone address First time zone start data:day First time zone start data:month Fourth time zone address Fourth time zone start data:day Fourth time zone start data:month	UINT8×12	R/W	Time table number: 01 Corresponds to the first set 02 Corresponds to the second set
002EH	Voltage of A phase	UINT16	R	Calculating factor:0.1 unit:V
002FH	Voltage of B phase	UINT16	R	
0030H	Voltage of C phase	UINT16	R	
0031H	Electricity of A phase	UINT16	R	Calculating factor:0.01 unit:A
0032H	Electricity of B phase	UINT16	R	
0033H	Electricity of C phase	UINT16	R	
0034H	Voltage between A-B	UINT16	R	Calculating factor:0.1 unit:V
0035H	Voltage between C-B	UINT16	R	
0036H	Voltage between A-C	UINT16	R	
0037H	PTValue	UINT16	R/W	Range of values (0~9999)
0038H	CTValue	UINT16	R/W	Range of values (0~9999)
0039H-003BH	Reserved			
003CH	First level code	UINT16	R/W	Range of values (0~9999)
003DH	Secondary code	UINT16	R/W	Range of values (0~9999)
003EH-0042H	Reserved			
0043H	Reserved			
0046H	Alarm amount 1	INT32	R/W	Calculating factor:0.01 unit: yuan
0048H	Alarm amount 2	INT32	R/W	

004AH	Credit amount	UINT32	R/W	
004CH	New purchase amount	INT32	R	
004EH	Times of power purchase	UINT16	R	Range of values (0~9999)
004FH	Remaining amount	INT32	R	Calculating factor: 0.01
0051H	Total purchase amount	INT32	R	Yuan
0053H-0056H	Reserved			
0057H	Mandatory control word	UINT16	R/W	0001: Override it 0000: Forced shutdown
0058H	On off control word	UINT16	R/W	0000: Forced closing 0001: Forced trip
0059H-0060H	Peak and valley electricity price	UINT32×4	R/W	Calculating factor:0.001 unit:yuan
0061H	Current threshold	UINT16	R/W	unit:W
0062H	Operation status word	UINT16	R/W	
0063H	Output mode	UINT16	R/W	0000: Level output 0001: Pulse output
0064H	Demand	UINT16	R	Calculating factor:0.001 Unit:kW
0065H	PA	INT32	R	Calculating factor:0.001 unit:kW
0067H	PB	INT32	R	
0069H	PC	INT32	R	
006BH	PT	INT32	R	
006DH	QA	INT32	R	Calculating factor:0.001 unit:kvar
006FH	QB	INT32	R	
0071H	QC	INT32	R	
0073H	QT	INT32	R	
0075H	SA	INT32	R	Calculating factor:0.001 unit:kVA
0077H	SB	INT32	R	
0079H	SC	INT32	R	
007BH	ST	INT32	R	
007DH	PFA	INT16	R	Calculating factor:0.001 Effective range (-1000~1000)
007EH	PFB	INT16	R	
007FH	PFC	INT16	R	
0080H	PFT	INT16	R	
0081H	Freq	INT16	R	Calculating factor:0.01
0082H-035FH	Reserved			
0360H	Main communication: Communication address and baud rate	UINT8×2	R/W	Communication parameters with ddsy1352
0361H	The main communication: Check bit stop bit	UINT8×2	R/W	
0362H-0364H	Reserved			
0365H	Deputy communication:Communica tion address and baud rate	UINT8×2	R/W	Communication parameters with DDSY1352
0366H	Deputy communication:Check bit stop bit	UINT8×2	R/W	
0367H-0369H				

036AH-1FFFH	Reserved			
2000H	Schedule 1: Session 1 tariff number Starting Time of session 1: Minutes Starting Time of session 1: hours Section 14 tariff number Starting Time of session 14: minutes Session 14 starting time: Hours	INT8×42	R/W	Rate Number: 01 for Pointy 02 for peaks 03 for Ping 04 for Valley
2015H	Schedule 2: Session 1 tariff number Starting Time of session 1: Minutes Starting Time of session 1: hours Section 14 tariff number Starting Time of session 14: minutes Session 14 starting time: Hours	INT8×42	R/W	Rate Number: 01 for Pointy 02 for peaks 03 for Ping 04 for Valley

DDSY1352, DTSY1352 Wireless parameter area

0x1300	Working mode of serial port	2	R/W	0:485 1: Print a wireless message
0x1301	Scheduled upload interval	2	R/W	
0x1302	16 bit serial number	16	R/W	ASCII SN [0] is low, SN [15] is high, SN [0] is first
0x1303				
0x1304				
0x1305				
0x1306				
0x1307				
0x1308				
0x1309				
0x130A	4-bit IP address	4	R/W	uint8_t IP[0]..IP[4] IP[0]
0x130B				
0x130C	Port number	2	R/W	
0x130D	Protocol mode / domain name identification	2	R/W	High bit 1: Protocol follows serial number Low bit0: IP 1: Domain Name
0x130E	24 bit domain name	24	R/W	ASCII DN [0] is low bit, DN [24] is high bit
0x130F				
0x1310				
0x1311				
0x1312				

0x1313				
0x1314				
0x1315				
0x1316				
0x1317				
0x1318				
0x1319				
0x131A	Number of devices / number of data segments	2	R/W	
0x131B	Number of alarm segments / TCP_ UDP mode	2	R/W	
0x131C	1Data length 1	2	R/W	
0x131D	2Data length 2	2	R/W	
0x131E	3Data length 3	2	R/W	
0x131F	4Data length 4	2	R/W	
0x1320	5Data length 5	2	R/W	
0x1321	6Data length 61	2	R/W	
0x1322	7Data length 7	2	R/W	
0x1323	8Data length 8	2	R/W	
0x1324	Data segment start address1	2	R/W	
0x1325	Data segment start address2	2	R/W	
0x1326	Data segment start address3	2	R/W	
0x1327	Data segment start address 4	2	R/W	
0x1328	Data segment start address 5	2	R/W	
0x1329	Data segment start address 6	2	R/W	
0x132A	Data segment start address 7	2	R/W	
0x132B	Data segment start address 8	2	R/W	
0x132C	Alarm segment control bit 1	2	R/W	
0x132D	Alarm segment control bit2	2	R/W	
0x132E	Alarm segment control bit 3	2	R/W	

0x132F	Alarm segment control bit 4	2	R/W	
0x1330	Alarm segment control bit 5	2	R/W	
0x1331	Alarm segment control bit 6	2	R/W	
0x1332	Alarm segment control bit 7	2	R/W	
0x1333	Alarm segment control bit 8	2	R/W	
0x1334	Firmware upgrade flag	4	R/W	
0x1335				
0x1336	Total number of firmware packages	4	R/W	
0x1337				

ADL100-EY、ADL300-EY Wireless information area

0x1700	Software number	2	R	
0x1701	Software version number	2	R	
0x1702	Server connection status / signal value	2	R	High 8 BITS: Server Connection Status Low 8 BITS: signal value
0x1703	System reset / hold	2	R	High 8 BITS: System Reset
0x1704--0x170F	SIM CCID	24	R	
0x1710	reserve	2	R	
0x1711	reserve	2	R	
0x1712	Number of wireless transmissions	2	R	
0x1713	Wireless reception times	2	R	
0x1714--0x172D	IMEI	20	R	

Headquarters: Acrel Co., LTD.

Address: No.253 Yulv Road Jiading District, Shanghai, China

TEL.: 0086-21-69158338 0086-21-69156052 0086-21-59156392 0086-21-69156971

Fax: 0086-21-69158303

Web-site: www.acrel-electric.com

E-mail: ACREL008@vip.163.com

Postcode: 201801

Manufacturer: Jiangsu Acrel Electrical Manufacturing Co., LTD.

Address: No.5 Dongmeng Road,Dongmeng industrial Park, Nanzha Street,Jiangyin City,Jiangsu Province,China

TEL: 0086-510-86179966

Fax: 0086-510-86179975

Web-site: www.jsacrel.com

Postcode: 214405

E-mail: sales@email.acrel.cn