

## Series BD electric transmitters

Installation and Operation Instruction V1.2

# DECLARATION

No part of this publication may be reproduced, stored in a retrieval system, or transmitted in any form by any means, electronic, mechanical photocopying, recording, or otherwise without prior permission of Acrel. All rights reserved.

This company reserve power of revision of product specification described in this manual, without notice. Before ordering, please consult local agent for the latest specification of product.

# CONTENTS

1 General.....	1
2 Type explanation.....	1
3 Technical condition.....	1
4 Outline dimension and install.....	2
4.1 Outline dimension and install.....	2
4.2 Wiring.....	3
5 Communication guide.....	4
5.1 Communication.....	4
5.2 MODBUS protocol compendium.....	4
5.3 Query-respond period.....	5
5.4 Transmission mode.....	5
5.5 Protocol.....	5
5.6 Method to create error check code (CRC).....	6
5.7 Communication apply format expound.....	7
5.8 Parameter Address table of BD100.....	8
6 Order examples.....	11

## 1 General

Series BD electric transmitters is a device which can isolate and transmit electric parameters, such as current, voltage, into linear DC analog signal or digital signal. It meets the requirements of National standard GB/T13850-1998, IEC-688.

## 2 Type explanation

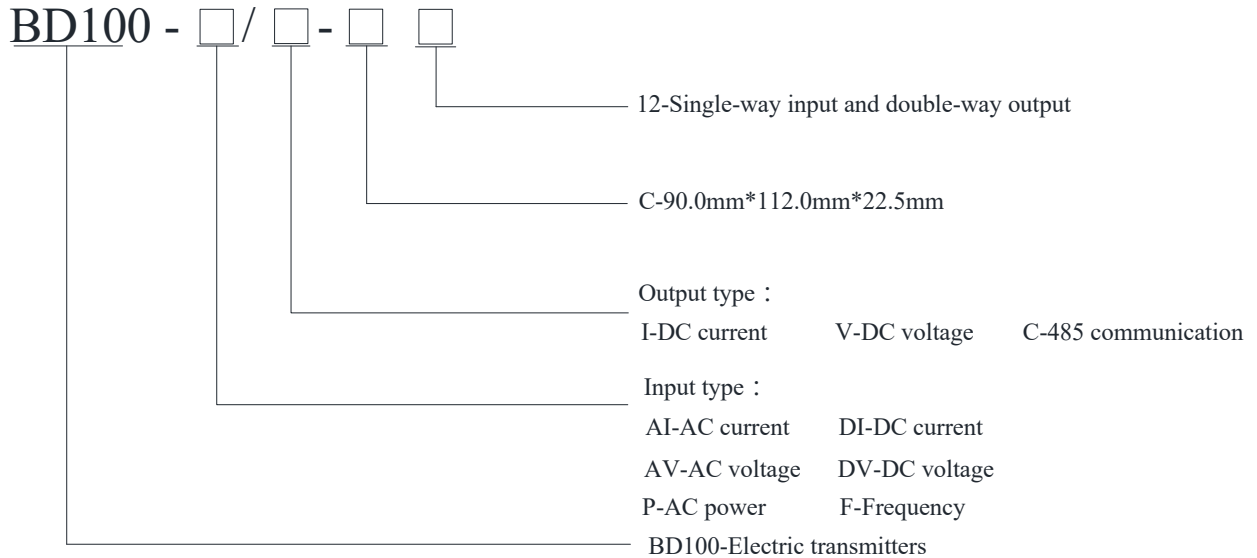

## 3 Technical condition

Technical parameters	Value
Input signal	AC current: AC0~1A、AC0~5A AC voltage: AC0~100V、AC0~400V、AC0~500V Frequency: 45~65Hz AC power: AC 0~2500W DC current: DC 0~1A、DC 0~5A DC voltage: DC0~100V、DC0~500V
Output signal	DC0~20mA、DC4~20mA; DC0~5V、DC1~5V、DC0~10V
Power supply	DC24V range: DC20V~35V; AC/DC220V range: AC/DC85V~265V
Accuracy class	0.2%
Temperature modulus	≤200ppm/°C
Response time	≤350ms
Isolation voltage	Among input//output//power supply 2.0kV/1min, leakage current≤1mA
Work /Storage temperature	-20°C~60°C/-25°C~70°C
Humanity	≤95% (In the place without dew)

Fix mode	TS35 Rail
----------	-----------

4 Outline dimension and install

4.1 Outline dimension and install

unit: mm

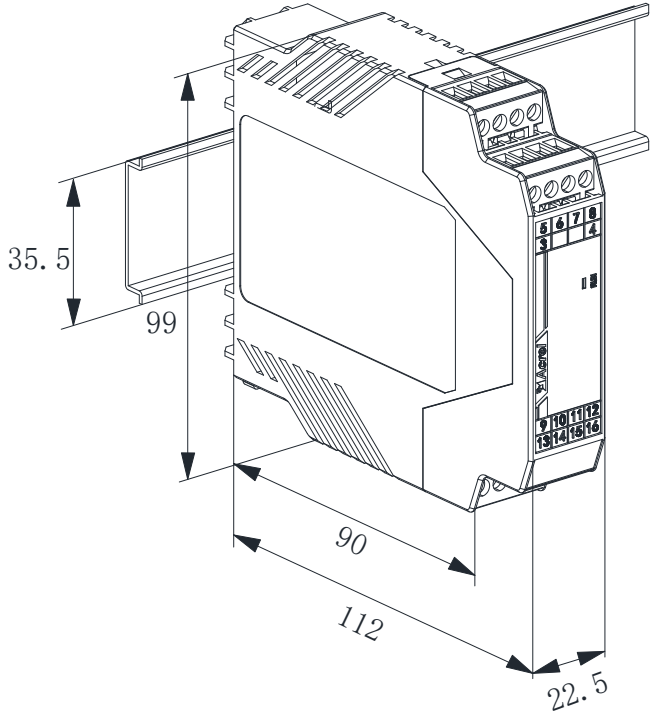

Outline C dimension



Shape C

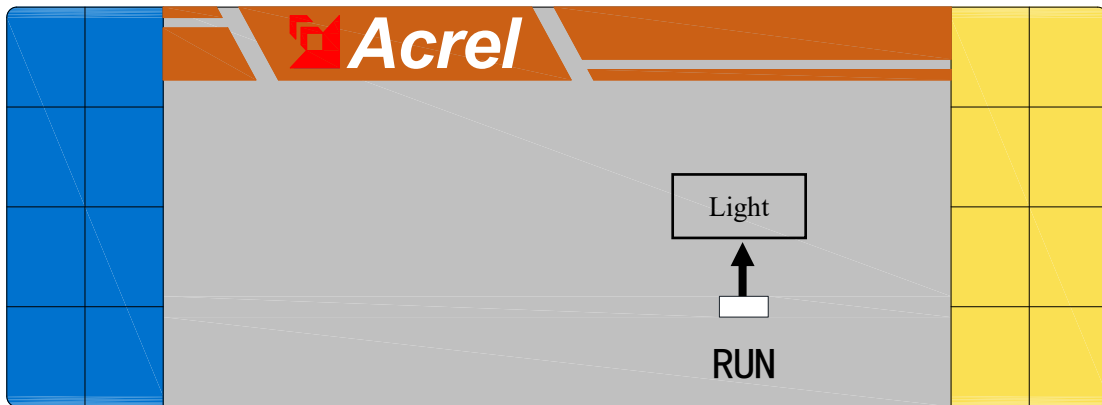

Light	Green	Red
Shape C	After power on, the light flashes once for 1s. After the RS485 communication is successfully connected, the light flashes once every 50ms.	When overvoltage or overcurrent occurs, the red light is on (Overvoltage and overcurrent alarm value is 120% of full scale signal)

#### 4.2 Wiring

BD100-□/□-C12

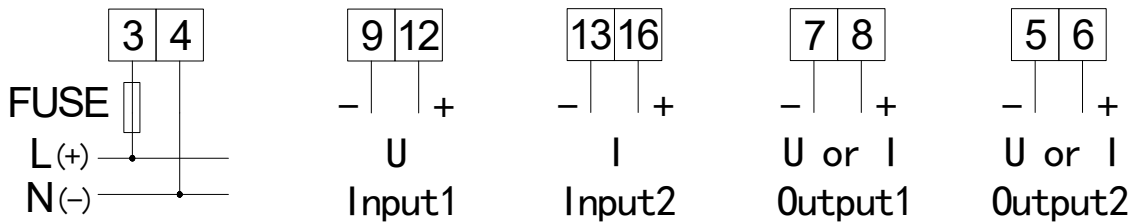

BD100-□/□C-C12

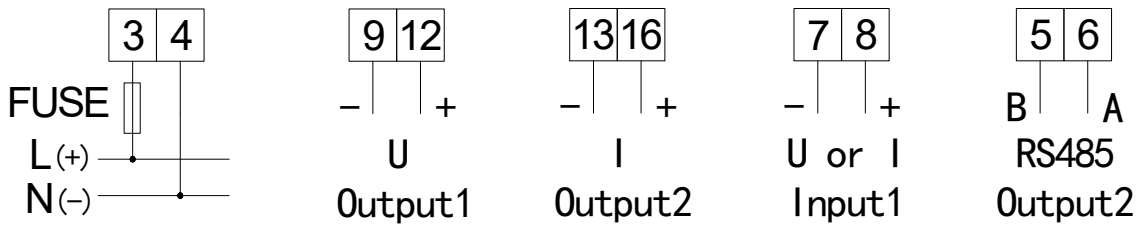

The wiring example of the communication part is shown in the figure below:

Correct wiring: communication cable shield grounding

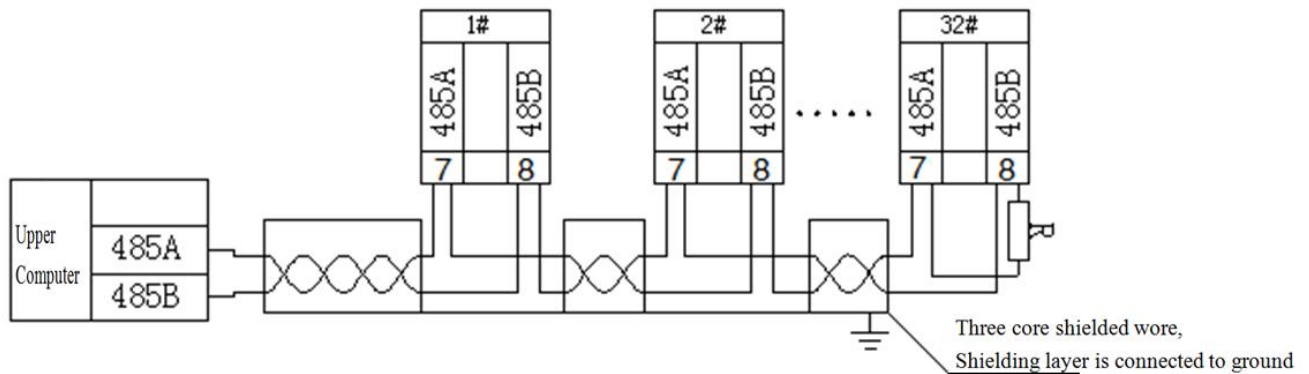

It is recommended to add matching resistance between A and B of the terminal instrument, and the resistance range is  $120\ \Omega \sim 10K\ \Omega$ .

The communication wiring instrument provides asynchronous half duplex RS485 communication interface and adopts MODBUS-RTU protocol. Various data information can be transmitted on the communication line. Theoretically, up to 128 network power instruments can be connected on one line at the same time, and each network power instrument can set its communication address (Addr). Shielded twisted pair is recommended for communication connection, and the wire diameter is not less than  $0.5\text{mm}^2$ . When wiring, keep the communication line away from strong current cables or other strong electric field environment.

## 5 Communication guide

### 5.1 Communication

This chapter mainly describes how to use software through communication port to operate and control this transmitter. To grasp content in this chapter, you should have enough knowledge accumulation of MODBUS protocol, read and familiar with all content of this manual, and full understanding of functions and application concept of this product.

This section covers: MODBUS protocol compendium, expounding communication apply formatting, details for applying this machine and parameter address table.

### 5.2 MODBUS protocol compendium

BD100 electric transmitters use MODBUS-RTU communication protocol, MODBUS protocol define detailedly: check code, data sequence etc., these are necessary content for specific data exchange. MODBUS protocol use master/slave responding connection (half-duplex) on one communication line, this means on one separated communication line, signal transmit in opposite directions. Firstly, master computer signal addressed only one terminal device (slave), then, the reply signal sent by terminal device transmit to the master in opposite directions.

MODBUS protocol only allow communication between the master (PC, PLCetc.) and terminal device, but not allow data exchange between independent terminal devices, so, each terminal device does not occupy communication line in the initialization, only respond query signal reach to the computer.

### 5.3 Query-respond period

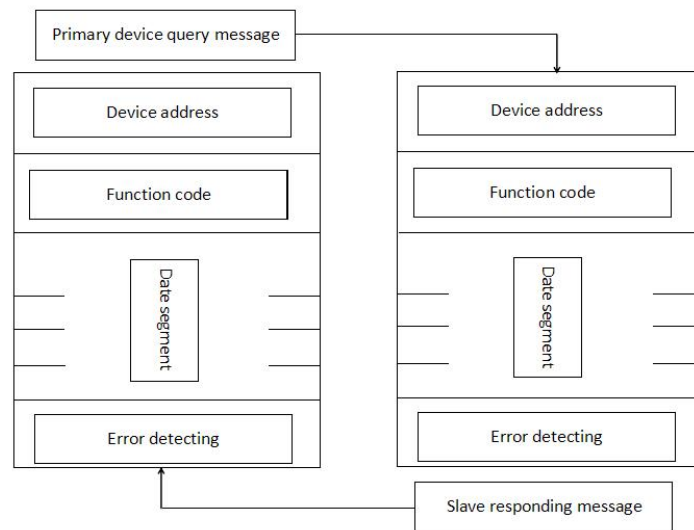

Master - slave query-respond period table

#### 5.3.1 Query

The functional code of query message tells the selected slave device to implement what function. Data segment included any additional message implemented function by slave device. For example: functional code 03 demand slave device to read holding register and return their content. The data segment must include message to be telling to slave device: the register starting read and register quantity to be read. Error detecting domain provide slave device with one method to verify the message content is correct or not.

#### 5.3.2 Respond

If slave device produce one normal respond, the functional code of respond message is enquiring the respond of functional code of query message. The data segment include data collected by slave device: such as register value or condition. If error occur, functional code will be revised to indicate that the respond message is wrong, while the data segment include code describing this error message. Error detecting domain allow primary device to confirm message content is usable or not.

### 5.4 Transmission mode

Transmission mode refer to one series of independent data structure, and limited regulation used for transmission data in one data frame, the transmission mode compatible with MODBUS protocol-RTU mode is defined as follows:

Bit of each byte:

- One start bit
- Eight data bit, least significance bit first transmitting
- Non-Parity bit
- 1 stop bit

Error detecting (Error checking)

CRC (cyclic redundancy check)

### 5.5 Protocol

When Data frame reach terminal device, enter addressed device by a simple "port" this device remove Data frame "envelope" (data head), read data, if there is no error, executing task requested by data, then, add the new produced data in the obtained "envelope", return the data frame to the transmitter. Returned responding data include following content: slave terminal address (Address), executed command (Function), requested data produced by executing command (Data) and one CRC check code (Check). If any error occur, no successful responding or returning one error indication frame.



### 5.5.1 Protocol

Address	Function	Data	Check
8-Bits	8-Bits	$N \times 8$ -Bits	16-Bits

### 5.5.2 Address domain

Address domain is located at beginning of frame, composed of one byte (8 bit binary system domain), decimal system is 0~255, in the ACR meters, just 1~247 is used, other address is Reserved. these bits indicate terminal device address specified by users, this device will receive the connecting host computer data. Every terminal device has its only one address, only the addressing terminal is responding enquiry including this address. When terminal is Transmitting one responding, the responding slave address data tell host computer that which terminal is communicating with it.

### 5.5.3 Function domain

Function domain tell the addressed terminal to execute what function. Below table list: function domain used in this Series meters, and their meaning and function.

Code	Meaning	Action
03	Read data register	Obtain current binary value of one or multiple register
16	Preset multi-register	Set binary value into a series of multiple register

### 5.5.4 Data domain

Data field is including the data needed by terminal for executing specific function, or the collected data when terminal is responding enquiry. Content of these data may be value, reference address or setting value. For example: The function domain tell terminal to Read one register, the data field need to specify the starting register and Read how many data, the built-in address and data have different content depending on type and slave computer.

### 5.5.5 Error check field

This field allows the error in checking and transmitting of host computer and terminal. Due to electric noise and other interfere, when one group of data is transmitting from one device to another device, on the transmitting line, some change may be produced. The error check can enable the host computer or terminal not responding those changed data, so, safety, reliability and efficiency of system are upgraded. It used 16 bit Cyclic Redundancy Check (CRC16).

### 5.6 Method to create error check code (CRC)

Error check (CRC) domain occupy 2 byte, including one 16 bit binary system value. CRC value is calculated by transmission device, then attached to the data frame, the receiving device, while receiving, it calculates the CRC value again, then comparing it with the receiving CRC domain value, if these two values is not equal, it shows a error occurs.

When operating, firstly, preset one 16-bit register as All-1, then continuously operating each byte 8 bit of Data frame and current value of this register, only every 8 data bit of each byte to participate in forming CRC the start bit and stop bit and usable parity bit have no affect on the CRC. When forming CRC, every 8 data bit of each byte and content of register carry out exclusive or operation, then shift the result to the low bit the high bit is filled with 0, shift out the least significant bit (LSB) is shifted out and tested, if it is 1, this register and one preset fixed value (0A001H) carry out one exclusive or operation, if the least significant bit is 0, no treating is needed.

The above said processing is performed repeatedly, until finishing shift operation for 8 times, after the last bit (8th bit) is shifted, the next 8 bit byte and register current value carry out exclusive or operation, after all byte of data frame have been treated, the result final value is CRC value.

Flow for forming one CRC:

1. Preset one 16 bit register as OFFFHH (All-1), called as CRC register.
2. 8 bit of data frame first byte and low byte of CRC register carry out exclusive or operation, then save its result back to CRC register.

3. Right shift CRC register for one bit, the most significant bit is filled with 0, the least significant bit is shifted out and tested.

4. If the least significant bit is 0, Repeat the third step (next shift); If the least significant bit is 1, CRC register and preset fixed value specified (0A001H) carry out exclusive or operation.

5. Repeat the third step and the fourth step until shift for 8 times, the complete 8 bit is done.

6. Repeat the second step to the fifth step to treat next 8 bit until all the byte is treated.

7. The CRC register final value is CRC value.

Besides, there is another CRC calculation method by preset table, its main feature is fast calculating speed, but large saving space is needed, please refer to related data.

## 5.7 Communication apply format expound

### 5.7.1 Read data (function code03)

#### Query data frame

This function allows user to obtain data and system parameter collected and recorded by device. The data number every requested by host computer have no limit, but must not exceed the defined Address range.

Below example is three basic data collected from reading No.01 slave (each Address of data frame occupy 2 byte)P, Q, S, therinto P's Address is 000CH, Q's Address is 000DH, S's Address is 000EH.

Addr	Fun	Data start Reg hi	Data start Reg lo	Data # of Regs hi	Data # of Regs lo	CRC16 lo	CRC16 hi
01H	03H	00H	0CH	00H	03H	C5H	C8H

#### Respond data frame

Respond include: slave Address, function code, data number and CRC error check.

Below example is result of reading P、Q、S(P=082CH, Q=082AH, S=082CH) respond.

Addr	Fun	Byte count	Data1 hi	Data1 lo	Data2 hi	Data2 lo	Data3 hi	Data3 lo	CRC16 lo	CRC16 hi
01H	03H	06H	08H	2CH	08H	2AH	08H	2CH	94H	4EH

#### Error indicating code

If the Address requested by host computer is inexistence, then return to Error indicating code: FFH.

### 5.7.2 Preset multi- register (function code16)

#### Query data frame

Function code16 allow user to change content of multiple register, system parameter in this transmitter, write in electric energy quantity with this function number. For the host computer, the most data number once written in is 16 (32byte).

Below example is that preset No.01 the voltage full scale is 220 ( $220 * 10 = 2200(0898H)$ ), voltage ratio is 10 (000AH), the corresponding addresses are 0029H, 002AH, total of 4 bytes.

Addr	Fun	Data start reg hi	Data start reg lo	Number of words written in reg hi	Number of words written in reg lo	Number of bytes written
01H	10H	00H	29H	00H	02H	04H

Value hi	Value lo	Value hi	Value lo	CCRC lo	CRC hi
08H	98H	00H	0AH	32H	55H

#### Error indicating code

If the Address requested by host computer is inexistence, or data number is not correct, then return to Error indicating code: FFH.

### 5.8 Parameter Address table of BD100

Measured value of this transmitter is read-out by 03 command and write-out by 16 command of Modbus-RTU communication protocol.

#### Secondary side data of electrical parameters

Secondary side data of electrical parameters						
Number	Word Address	Parameter	Read/Write	Word length	Data type	Data analysis
1	0x00	—	—	—	—	—
2	0x01	Temperature	R	1	Integer	Data * 0.01 °C
3	0x02	DC voltage	R	1	Integer	Data * 0.1 V
4	0x03	AC voltage	R	1	word	Data * 0.1 V
5	0x04	—	—	—	—	—
6	0x05	DC current	R	1	Integer	Data * 0.001 A
7	0x06	AC current	R	1	word	Data * 0.001 A
8-11	0x07-0x0A	—	—	—	—	—
12	0x0B	Frequency	R	1	word	Data * 0.01 Hz
13	0x0C	Active power	R	1	Integer	W
14	0x0D	Reactive power	R	1	Integer	Var
15	0x0E	Inspecting power	R	1	word	W
16	0x0F	Power factor	R	1	Integer	Data * 0.001
17-41	0x10-0x28	—	—	—	—	—
42	0x29	Voltage full scale	R/W	1	word	0-9999 Data = actual voltage full scale*10
43	0x2A	Voltage ratio	R/W	1	word	0-9999
44	0x2b	Current full scale	R/W	1	word	0-9999 Data = actual current full scale*1000
45	0x2c	Current ratio	R/W	1	word	0-9999

#### First side data of electrical parameters

First side data of electrical parameters						
Number	Word Address	Parameter	Read/Write	Word length	Data type	Data analysis
1	0x500~0x501	DC voltage	R	1	Fword	V
2	0x502~0x503	DC current	R	1	Fword	A
3	0x504~0x50f	—	—	—	—	—

4	0x510~0x511	AC voltage	R	1	Fword	V
5	0x512~0x513	AC current	R	1	Fword	A
6	0x514~0x515	Active power	R	1	Fword	W
7	0x516~0x517	Reactive power	R	1	Fword	Var
8	0x518~0x519	Inspecting power	R	1	Fword	W
9	0x51a~0x51b	Power factor	R	1	Fword	——

System Parameter						
Number	Word Address	Parameter	Read/Write	Word length	Data type	Remarks
1	0x258	——	——	—	——	——
2	0x259	Meter type	R/W	1	word	0: AC 1: DC voltage 2: DC current
3	0x25a hi	Communication Address	R/W	1	BYTE	1-247
	0x25a lo	Communication Baud rate	R/W		BYTE	0-5: 9600, 19200, 38400, 1200, 2400, 4800
4	0x25b hi	——	——	——	——	——
	0x25b lo	Check digit	R/W	1	BYTE	0:No check digit 8 data bits 1 stop bit 1: No check digit 8 data bits 2 stop bits 2: Odd parity 8 data bits 1 stop bit 3: Even parity 8 data bits 1 stop bit
5	0x25c	——	——	—	——	——
6	0x25d hi	Transmit 1output type	R/W	1	BYTE	0:0-20mA 1:4-20mA 2:0-5V 3:0-10V 4:1-5V
	0x25d lo	Transmit 1 parameter selection	R/W		BYTE	0: u 1: i 3: freq 4:P 6:Q 8:S 10:Pf
7	0x25e	Transmit 1high value	R/W		Integer	0-9999
8	0x25f	Transmit 1low value	R/W		Integer	0-9999
9	0x260	——	——	—	——	——

10	0x261 hi	Transmit 1 output type	R/W	1	BYTE	0:0-20mA 1:4-20mA 2:0-5V 3:0-10V 4:1-5V
	0x261 lo	Transmit 1 parameter selection	R/W		BYTE	0: u 1: i 3: freq 4:P 6:Q 8:S 10:Pf
11	0x262	Transmit 2 high value	R/W		Integer	0-9999
12	0x263	Transmit 2 low value	R/W		Integer	0-9999

Instructions:

1 Data type: "BYTEV"=one byte; "word"=16 bit unsigned integer; "Integer"=16 bit signed integer; "Dword"=32 bit unsigned integer; "Fword"=32 bit floating point numbers..

2 Read/Write Properties: "R"=Read only, Read parameter use 03H Command; "R/W"= Readable/Writable, Write system parameter use 10H Command. Prohibit write in Address, which is not listed or without writable properties.

3 Electric energy primary side value adopt floating point variable data type. It uses sign bit to show number sign, use biased exponent and mantissa to show larger and smaller numbers. Data format adopted by transmitter is IEEE754, with 24 bit precision, high bit of mantissa is always "1", thus, Don't Save, bit distribution is shown as following:

- a) 1 bit as sign bit;
- b) 8 bit exponents bit;
- c) 23 bit mantissa.

Sign bit is the highest bit, mantissa is the lowest 23 bit, the description based on byte is shown as follows:

Address	+0	+1	+2	+3
Content	SEEE EEEE	EMMM MMMM	MMMM MMMM	MMMM MMMM

Thereinto, S: Sign bit, 1 shows negative, 0 shows positive;

E: biased exponent (in two bytes) biased 127;

M: 23 bit mantissa, its highest bit is "1".

For example:

Read-out 0 10001110 100 1011 1010 1100 0000 0000B

0 shows sign bit, "1"negative, "0"positive;

10001110=gage index, set it to a, a is decimal system, a=142;

100 1011 1010 1100 0000 0000 is computing mantissa, set it to b, b is decimal system, b=4959232.

Computing formula:

$$\text{Primary side electric parameters} = (-1)^S \times 2^{(E-127)} \times \left(1 + \frac{M}{2^{23}}\right)$$

Computed result:

$$= (-1)^0 \times 2^{(142-127)} \times \left(1 + \frac{4959232}{2^{23}}\right) = 52140$$

## 6 Order examples

E.g. Type: BD100-AV/V-C12

Auxiliary power supply: AC/DC 85-265V

Input: DC 0-500V

Output 1: DC 4~20mA

Output 2: DC 4~20mA

Type: BD100-DI/VC-C12

Auxiliary power supply: DC 24V

Input: DC 0-5A

Output 1: DC 0-10V

Output 2:RS485

Headquarter: Acrel Co., Ltd.

Add: No.253 Yulv Road, Madong Industrial Park, Jiading District, Shanghai, China

Tel: (86) 21-69158338 69156052 69156392 69156971

Fax: (86) 21-69158303

[Http://www.acrel.cn](http://www.acrel.cn)

E-mail: [ACREL001@vip.163.com](mailto:ACREL001@vip.163.com)

PC: 201801

Production Base: Jiangsu Acrel Appliance Manufacture Co., Ltd.

Add: 5 Domeng Road Dongmeng Industrial Park Nanzha town Jiangyin

Tel: (86) 0510-86179966

Fax: (86) 0510-86179975

[Http://www.jsacrel.cn](http://www.jsacrel.cn)

E-mail: [sales@email.acrel.cn](mailto:sales@email.acrel.cn)

PC: 214405