

# DTSD1352-4S DIN-rail Type Multi-circuit Power Meter

Installation and Use Manual V1.0

Acrel Co., Ltd.

# Declaration

The copyright is the property of Acrel. Any information in any paragraph or section cannot be extracted, copied or otherwise reproduced or propagated. Otherwise offenders shall take all consequences.

All rights are reserved.

Acrel reserves the right to modify the product specifications herein without notification. Please consult the local agent about the latest specifications before placing a purchase order.

# Content

1 Overview.....	1
2 Product function and technical parameter.....	1
2.1 Product function.....	1
2.2 Main technical parameter.....	1
2.3 Other technical parameter.....	2
3 Matching transformers.....	2
4 Dimension and installation instruction.....	3
4.1 Dimension (Unit:mm).....	3
4.2 Wiring Instruction.....	3
5 Usage and operation guide.....	5
5.1 Panel description.....	5
5.2 Display description.....	6
5.3 Information view.....	6
5.4 Setting option.....	8
6 Communication description.....	15
6.1 Communication address.....	15
6.2 Energy freeze address table.....	46
6.3 Data record address table.....	48
7 Common Troubleshooting.....	49

## 1 Overview

DTSD1352-4S series DIN-rail type multi-circuit power meter is mainly used for the full electric parameter measurement of multiple circuits, and can be connected to the current input of 4 three-phase circuits or 12 single-phase circuits at the same time. It can measure parameters such as voltage and current, power, power factor, phase angle, unbalance, and harmonics.

## 2 Product function and technical parameter

### 2.1 Product function

The specific functions are as follows:

- ✧ 4-way three-phase or 12-way single-phase loop full electric parameter measurement, external current transformer;
- ✧ Monitoring each phase voltage/current, zero sequence current, frequency;
- ✧ Monitoring each phase power and total power (active, reactive, apparent);
- ✧ Monitoring each phase power factor and total power factor;
- ✧ Monitoring voltage/current phase angle, voltage/current unbalance;
- ✧ Monitoring total voltage/current harmonics and 2nd to 31th harmonics;
- ✧ Recording voltage, current and power extreme value of the current month and the previous month;
- ✧ Maximum current, maximum power demand and real-time current, real-time power demand;
- ✧ 200 event loggings to record the actions of DIDO;
- ✧ Supporting overvoltage, overcurrent, phase failure, DI linkage and other alarm output;
- ✧ Rate setting for 4 time zones and 14 time periods;
- ✧ Four-quadrant energy, 12-month multi-rate energy statistics;
- ✧ 31-day four-quadrant and multi-rate energy freeze, forward and reverse energy metering;
- ✧ Four passive switch inputs, two active switch inputs, one switch output, RS485 communication;
- ✧ Two-way passive switch input, two-way switch output, RS485 communication;

Note: It can only choose either-or between four passive switch inputs, two active switch inputs, one switch output and two passive switch inputs, two switch outputs.

### 2.2 Main technical parameter

Table 1 DTSD1352-4S Main technical parameter

Auxiliary Power		AC/DC 85~265V; power consumption≤10VA;	
Input Signal	Frequency		45~65Hz;
	Voltage		Rated value: AC 3×220V/380V;
			Overload: 1.2 times rated value (continuous); 2 times rated value/1 second;
			power consumption: ≤ 0.5VA (each channel) ;
	Current		Rated value: Secondary input rated current: 50mA
			Overload: 1.2 times rated value (continuous); 10 times rated value/1 second;
power consumption: ≤ 0.5VA (each channel) ;			
Measurement Accuracy		Frequency: 0.05Hz, voltage and current: 0.5 class, active energy: 1 class, reactive energy: 2 class; 2nd to 31st harmonic accuracy: ±1%;	
Function	Pulse output		Output method: optocoupler pulse with open collector (and active open input can only be either-or.);
	communication		RS485 interface, Modbus-RTU protocol; baud rate 1200~38400;
	Switch	Input	2-way or 4-way passive dry contact input, built-in power supply;

			2-way active wet node input (AC220V), identify the oil generator and mains access (and pulse output can only be either-or.);
		Output	Output method: relay normally open contact output; Contact rating: AC 250V/3A DC 30V/3A;

### 2.3 Other technical parameter

Table 2 Other technical parameter

Safety	Power frequency withstand voltage	>AC 2kV/1min;
	Insulation resistance	Input and output terminals to the chassis >100MΩ;
Environment		Operating temperature: -20℃~+60℃; Storage temperature: -40℃~+70℃; Relative humidity: ≤95% no condensation; Altitude: ≤2500m;
Electromagnetic Compatibility		better than 3 class;

### 3 Matching transformers

The current transformer is a crystal head interface, the primary side current is 100A-600A, and the secondary side output current is 50mA. If the current transformer is different, the customer can modify the current transformation ratio through the instrument interface or communication according to the actual use. The transformer is shown in Figure 1 and Figure 2.



Figure 1

The total length is 1+0.5m, and it is divided into three lines of red, green and yellow in the 0.5m section, of which yellow is phase A, green is phase B, and red is phase C. The connection terminal with the meter adopts the network cable port, and the terminal definition is as follows:

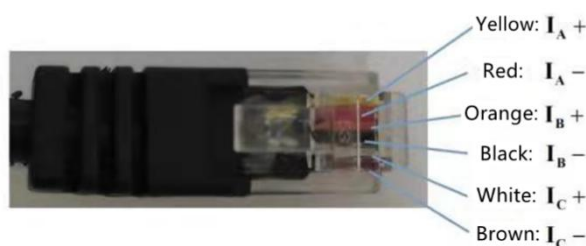

Figure 2

Table 3 DTSD1352-4S Matching current transformers

Type	Ratio	Line Length	Accuracy	Installation Method
AKH-0.66/W-12NY 100A/50mA	100A/50mA	(1+0.2) m	0.2 class	Closed type, crystal head interface
AKH-0.66/K-Φ16N 100A/50mA	100A/50mA	(1+0.2) m	0.5 class	Open type, crystal head interface
AKH-0.66/W-20Y 200A/50mA	200A/50mA	(1+0.5) m	0.2 class	Closed type, crystal head interface
AKH-0.66/K-Φ24N 200A/50mA	200A/50mA	(1+0.5) m	0.5 class	Open type, crystal head interface
AKH-0.66/W-30NY 250A/50mA	250A/50mA	(1+0.5) m	0.2 class	Closed type, crystal head interface
AKH-0.66/K-Φ24N 250A/50mA	250A/50mA	(1+0.5) m	0.5 class	Open type, crystal head interface
AKH-0.66-TD-Φ60-NY	400A/50mA	(1+0.5) m	0.2 class	Closed type, crystal head interface

AKH-0.66/K-Φ36N 400A/50mA	400A/50mA	(1+0.5) m	0.5 class	Open type, crystal head interface
AKH-0.66-TD-Φ60-NY	600A/50mA	(1+0.5) m	0.2 class	Closed type, crystal head interface
AKH-0.66/K-Φ36N 600A/50mA	600A/50mA	(1+0.5) m	0.5 class	Open type, crystal head interface

Note: For special transformers, please contact for specific consultation.

## 4 Dimension and installation instruction

### 4.1 Dimension (Unit: mm)

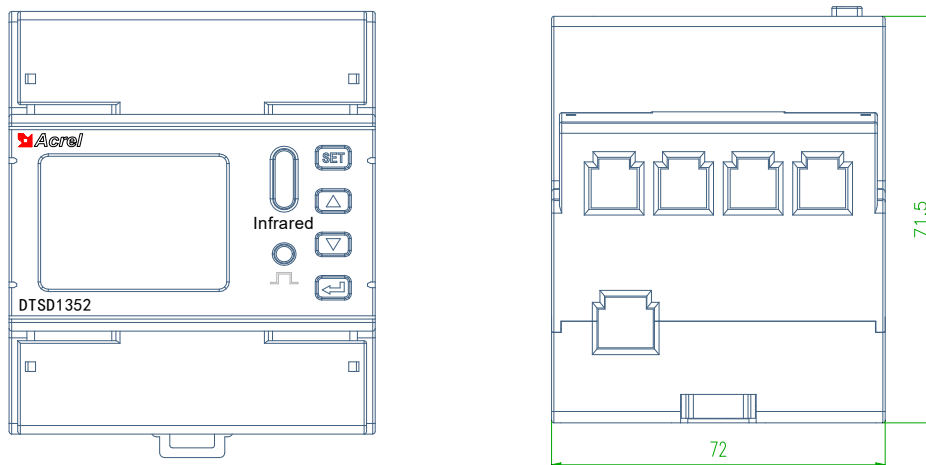

Figure 2 DTSD1352 - 4S dimension

Table 4 DTSD1352 - 4S Module Dimension

	Shape Dimension (mm)				Rail Dimension (mm)	Tolerance (mm)
	Length	Width	Height	with terminal length		
Single Module	87.8	72	71.5	97.7	35	±1

### 4.2 Wiring Instruction

The wiring terminals are shown in the figure below

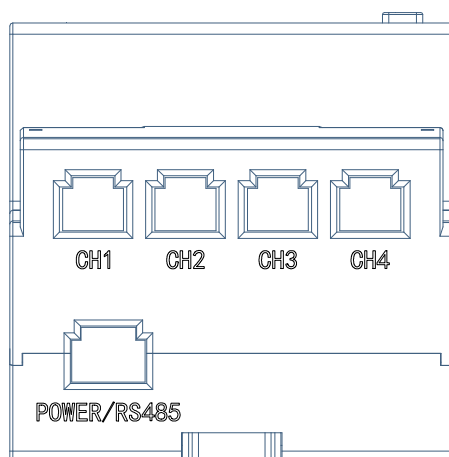

Figure 3

DTSD1352-4S (2DI2DO) module front wiring terminals

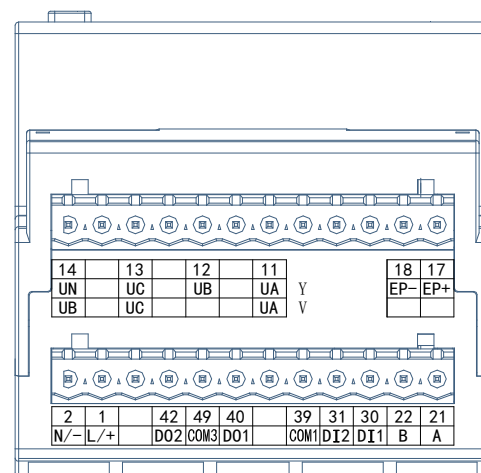

Figure 4

DTSD1352-4S (2DI2DO) module reverse wiring

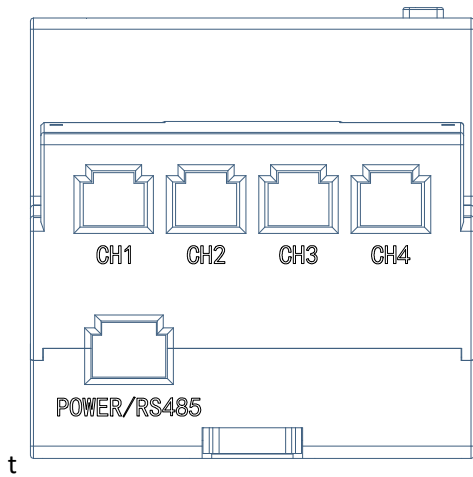

Figure 5

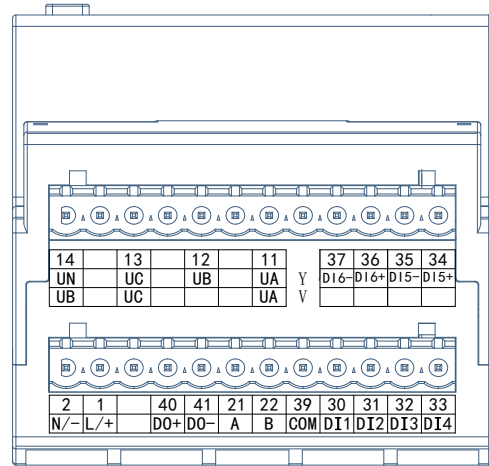

Figure 6

DTSD1352-4S(6DI1DO) module front wiring terminals

DTSD1352-4S(6DI1DO) module reverse wiring terminals

**Note: DI5+, DI5-, DI6+, DI6- are active switch inputs, connected to AC220V.**

Terminal interface description

DTSD1352-4S(2DI2DO):

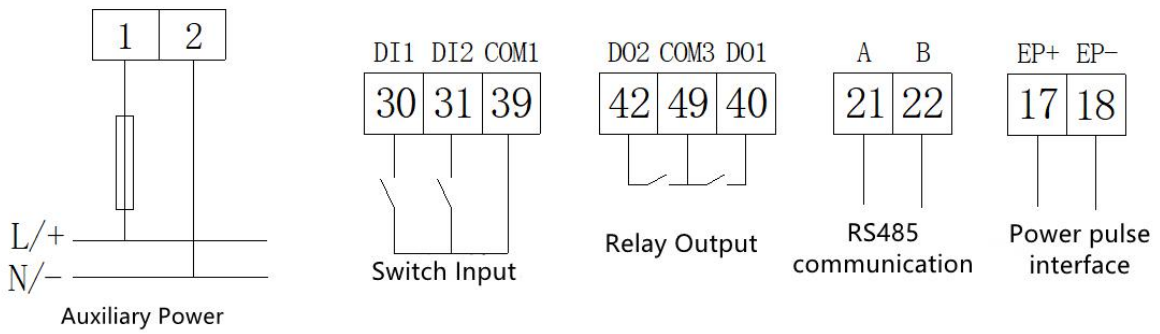

DTSD1352-4S(6DI1DO):

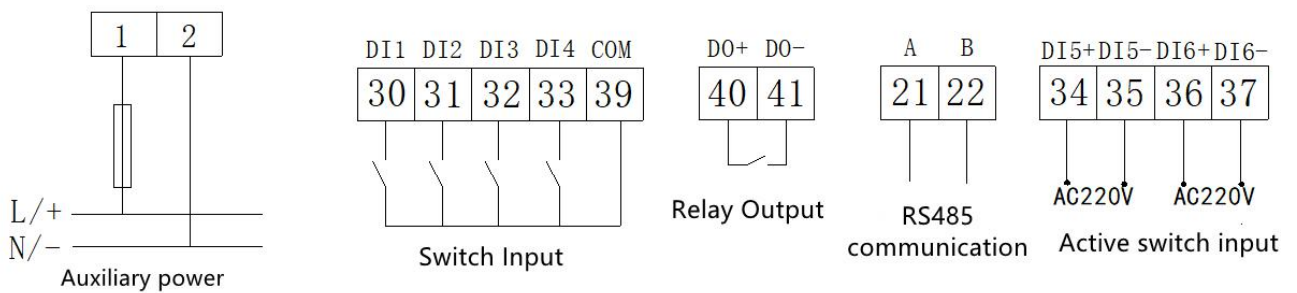

Wiring Method

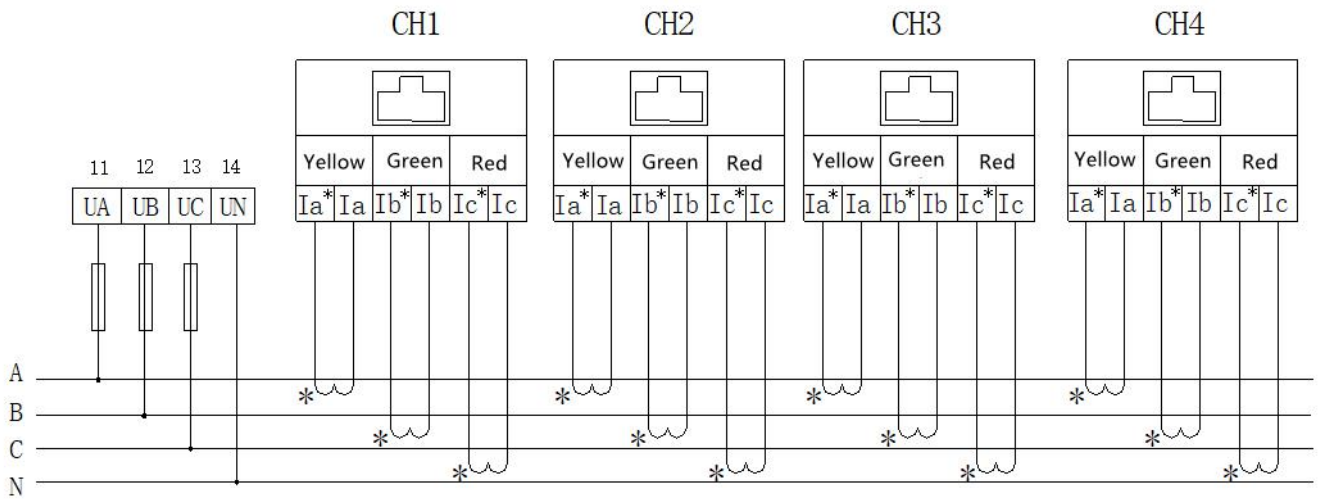

Figure 7 Three-phase four-wire voltage and current are directly connected

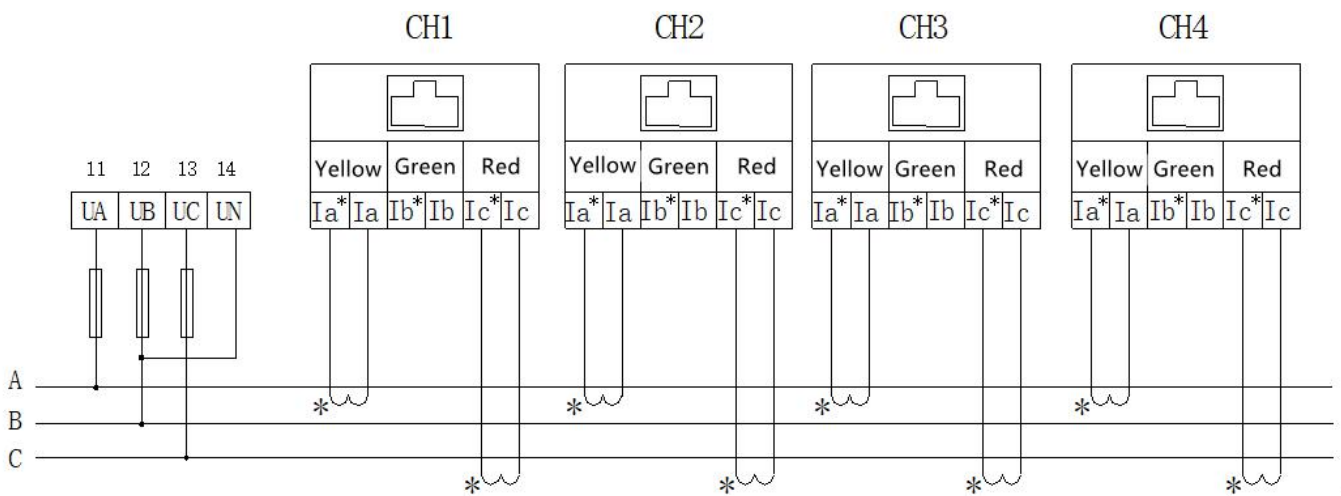

Figure 8 Three-phase three-wire voltage and current are directly connected

## 5 Usage and operation guide

### 5.1 Panel description

<p>SET button (SET)</p>	<p>In the measurement mode, press this button to enter the programming mode, the meter prompts to enter the password. After entering the correct password (0001), the meter can be programmed;</p> <p>In the programming mode, it is used to return to the previous menu.</p>

Up button (▲)	In the measurement mode, it is used to switch loops; In the programming mode, it is used to switch the digit of the same level menu or data.
Down button (▼)	In the measurement mode, it is used to switch display items; In the programming mode, it is used to switch the same level menu or increase the number of digits.
Enter button (↵)	In the measurement mode, it is used to switch display items; In programming mode, it is used to confirm the selection of menu items and the modification of parameters.

## 5.2 Display description

The following figure shows the screen when all character fields and indications are

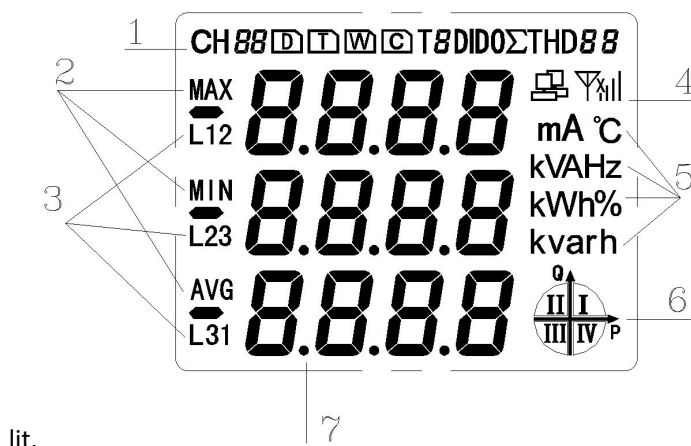



Figure 9

Table 4 below describes all measurements and indications

Table 4

Serial Number	Display Content	Explanation
1	CH01,CH02,CH03,CH04	Loop 1-4
	Σ	sum
	I/P/Q/S/PF/U/HZ/	Identify the content displayed in the current measurement data display area 88: current/ active power/ reactive power/ apparent power/ power factor/ voltage/ frequency
	THD88	number of harmonics
	T1,T2,T3,T4	Current multi-tariff rate: T1 sharp, T2 peak, T3 flat, T4 valley
2	MAX/MIN/AVG	Maximum/Minimum/Average record
3	L1,L2,L3,L12,L23,L31	L1,L2,L3 three phase value, L12,L23,L31 three phase line value
4		When it lights up, it indicates that the current communication is normal.
5	Indication measurement data unit	Current: A,kA; Voltage: V,kV; Active power: kW; mA: milliampere; °C: temperature; Reactive power: Kvar; Apparent power: kVA; Percentage: %
6	Angle	Four-quadrant energy
7	Measurement data display area	Current, voltage, power, power factor, time, parameter setting, etc.

## 5.3 Information view

The meter measures electrical parameters such as voltage, current, power, power factor, frequency, demand, electric

energy, extreme value, etc., which can be viewed through the meter screen. However, some parameters can only be read through communication. For specific information, please refer to the address information table.

The display example of the basic power is shown in the figure below

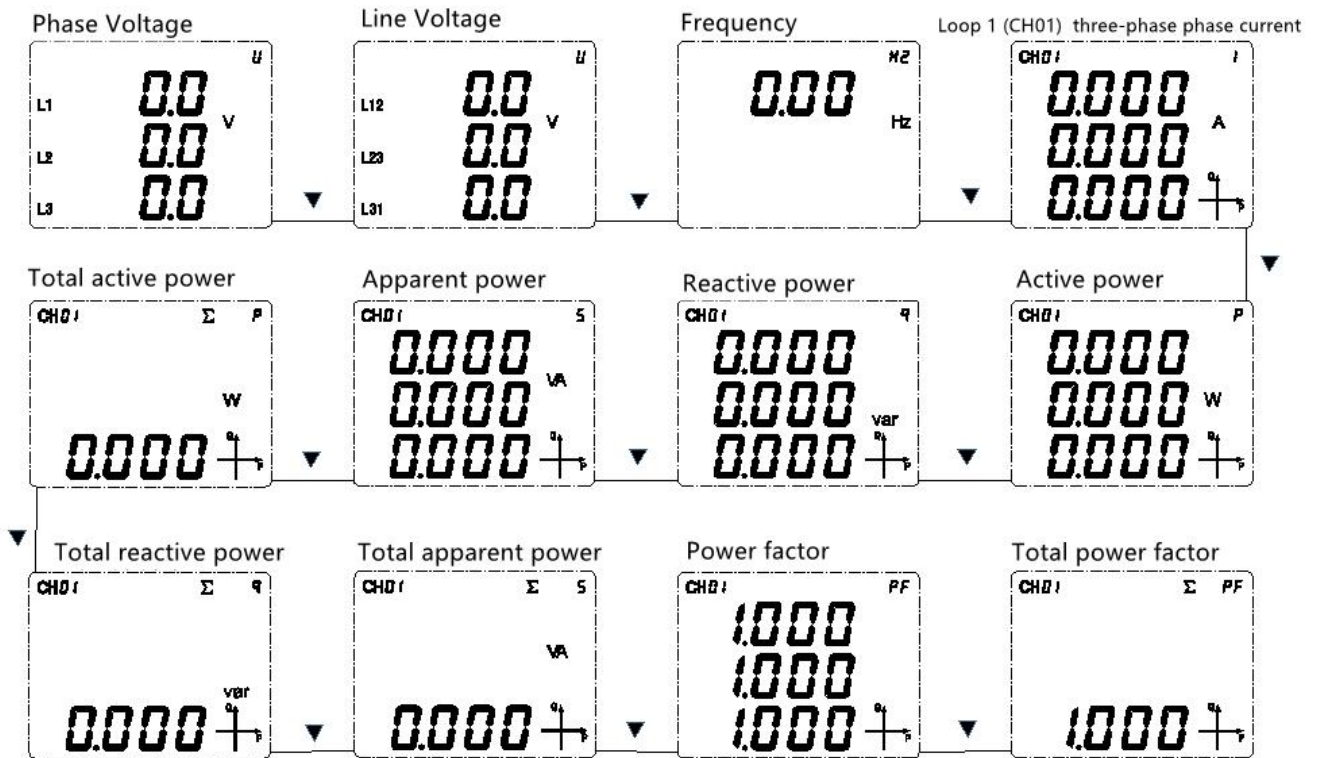

Note: 1. L1, L2, L3 correspond to UA, UB, UC; L12, L23, L31 correspond to Uab, Ubc, Uca  
 2. "CH01", "CH02", "CH03", "CH04" represent four circuits respectively  
 3. To view the electrical parameters of other circuits, press the "▲" button to switch and view. For example: to view the three-phase current of the other circuits, you can operate the three-phase current of circuit 1 as shown above. Then press the "▲" button to switch to view the three-phase current of the remaining circuits as shown in the figure below.

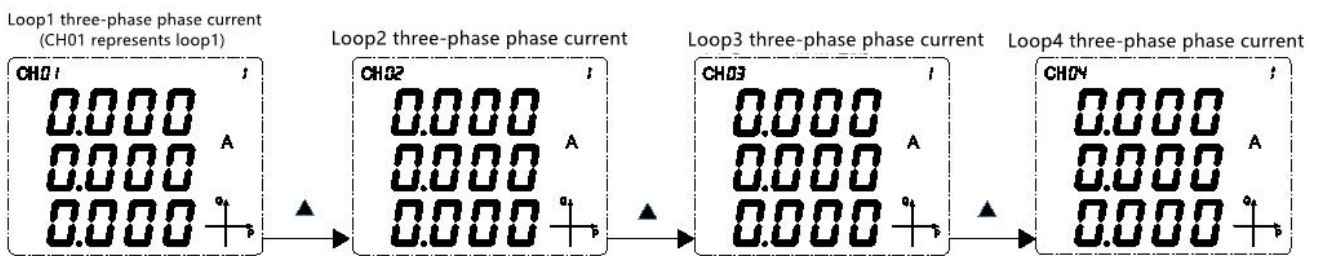

### 5.3.2 Energy metering

The meter can measure A/B/C phase positive active power, total positive active power, A/B/C negative active power, total negative active power, A/B/C phase positive reactive power, total positive reactive power, A/B/C negative reactive energy, total negative reactive energy, voltage/current subharmonics. Users can manually reset and clear power data according to their own needs (user password is required).

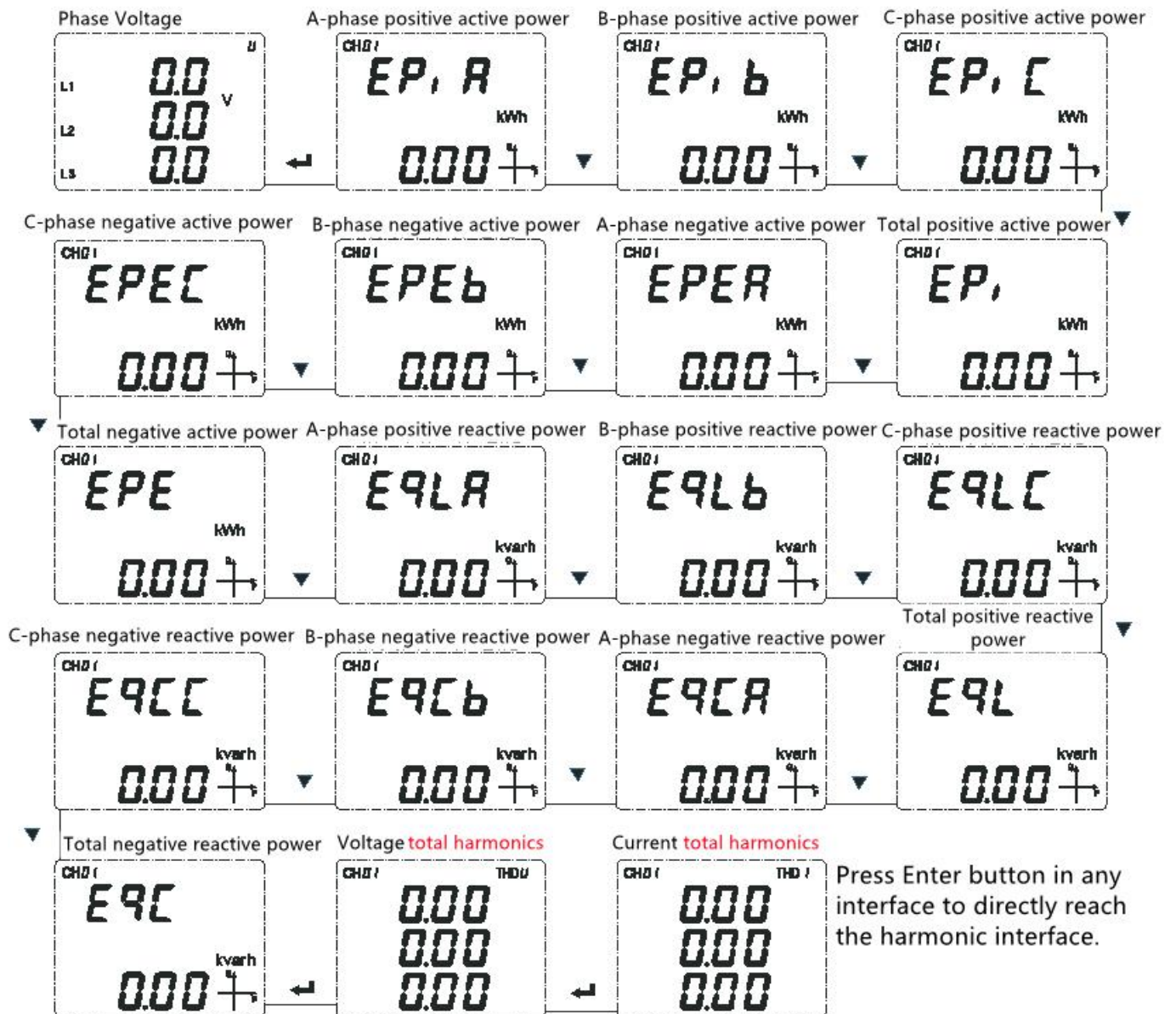

Note: Refer to Note 3 in 5.3.1 for the electrical parameters of other circuits

#### 5.4 Setting Option

For the detailed description of the setting menu, see the table below for the character code description of the setting menu.

The first level	The second level	The third level	Explanation
System Setting 545	CodeE	0~9999	User password
	PLUS	100A:400、250A:100	Pulse constant
	bLcd	0~250s	Backlight Duration
	AP	L1 L2 L3 L4 E, ÑE	Power Pulse Selection L1-L4: Active energy pulses for 4 circuits

		1L 1L2 1L3 1L4	t, nE : clock pulse 1L1-1L4: 1L means one pulse of active energy per kilowatt hour, 1-4 means 4 circuits
	CLr	6401: Clear demand records 6402: Clear extreme value records 6403: Clear historical energy 6404: Clear frozen data 6405: Clear power 6406: Clear multi-tariff rate energy 6407: Clear event loggings	Clear records
Signal Input	Line	3P4L: three phase four line 3P3L: three phase three line	Wiring method
	UPr	220-65000V	Primary side voltage rating
	USEC	220-65000V 100V 220V	Secondary side voltage rating
	iPr	5-50000A	Primary side current rating with four loops
	iSEC	100A、250A	Secondary side current rating
	U.noñ	220-65000V	Secondary voltage nominal value
	F.noñ	45-65Hz	Frequency nominal value
The 1st communication	Addr	1~247	Communication address
	bAUD	1200, 2400, 4800, 9600, 19200, 38400	Communication baud rate
	dARA	n.8.2 : No parity, 2 stop bits n.8.1 : No parity, 1 stop bits o.8.1 : Odd parity E.8.1 : even parity	Communication check digit
Demand	ñodE	SL, P : Slip F, 4 : Fixed	Demand work mode

	<i>y, d</i>	1-999s	Demand slip time
	<i>Pd</i>	1-30T	Demand calculation cycle
Alarm setting <i>do-1</i> <i>do-2</i>	<i>SEL</i>	0: Remote control 1-34: Alarm	Alarm working mode (see chapter 5.4.6)
	<i>ALCH</i>	CH1-4	Alarm loop
	<i>dLY</i>	0-9999	Delay time
	<i>bRNd</i>	1	Alarm hysteresis
	<i>ALH<sub>1</sub></i>	999	High alarm set point
	<i>ALL<sub>o</sub></i>	0	Low alarm set point
	<i>In=0</i>	ON or OFF	Zero Alarm Enable

#### 5.4.1 Enter programming mode

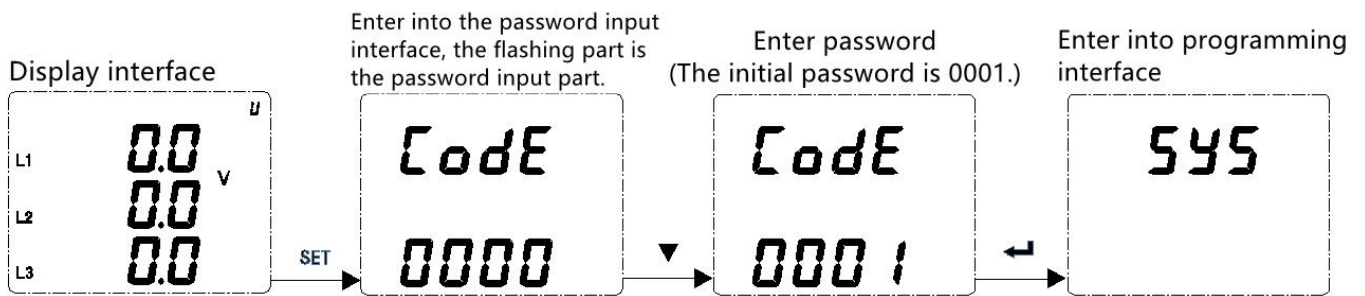

#### 5.4.2 Modify user password, pulse constant, backlight duration, power pulse selection and clear record

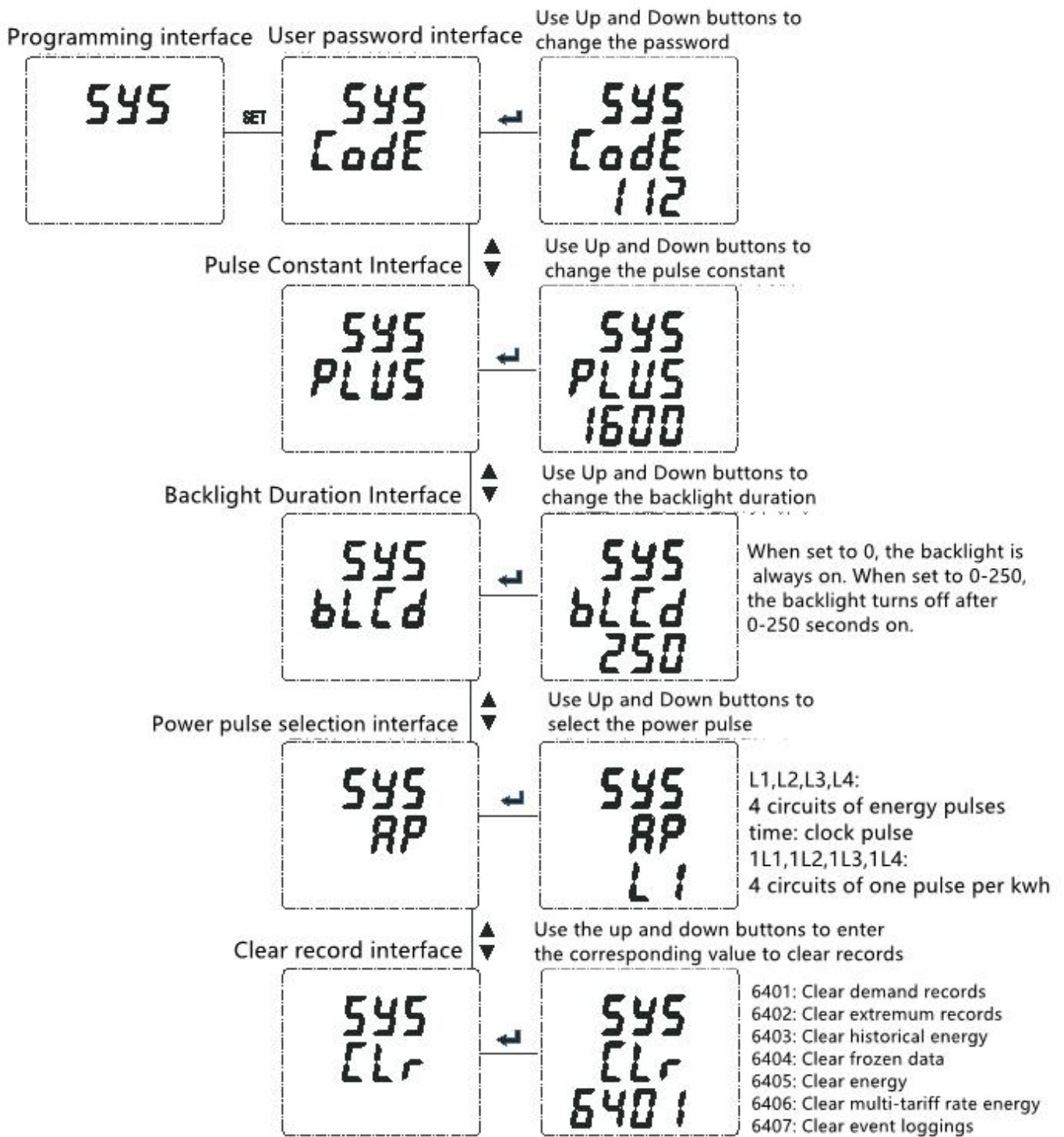

5.4.3 Modify the wiring method, primary (secondary) voltage (current) rated value, secondary voltage nominal value and frequency nominal value

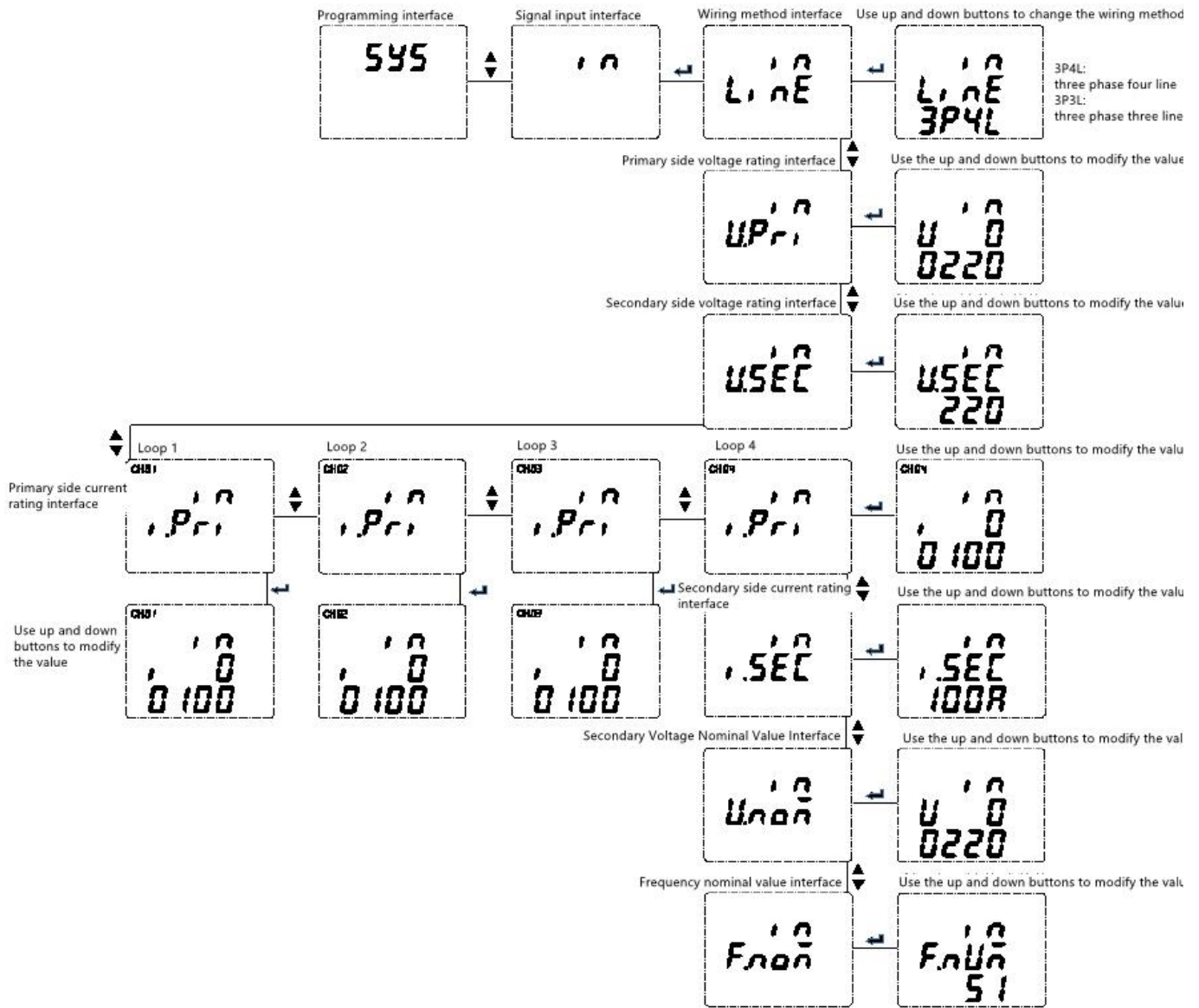

5.4.4 Modify the communication address, baud rate and check bit.

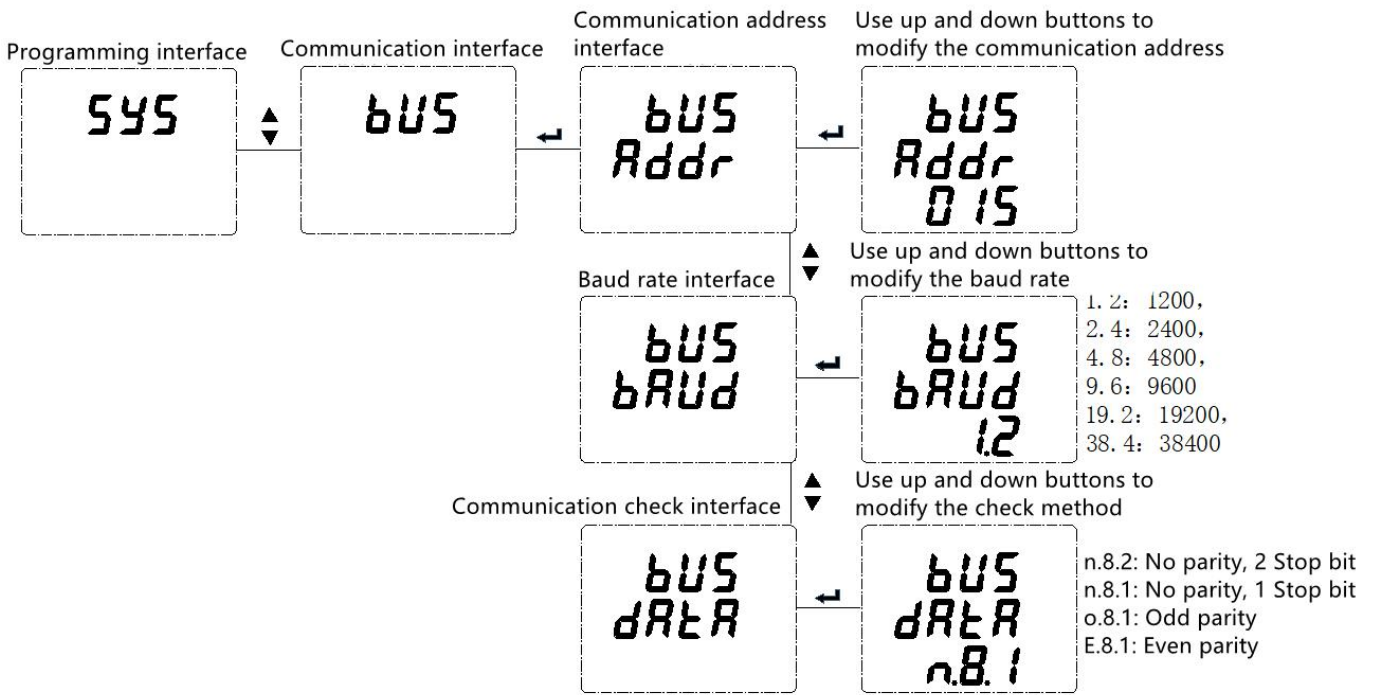

5.4.5 Modify the working mode of demand, slip time and calculation time.

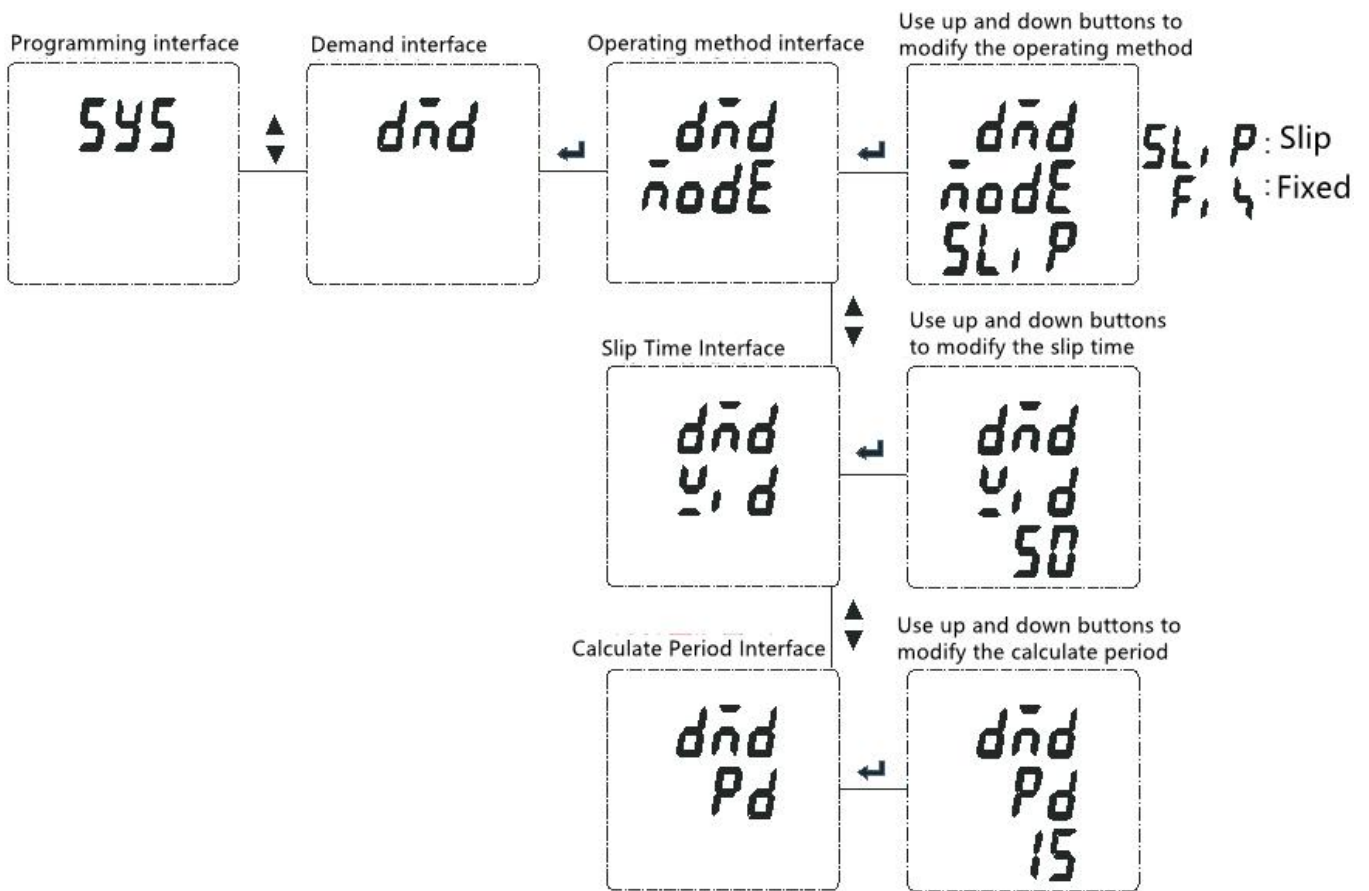

5.4.6 Modify switch working mode, alarm loop, delay time, alarm hysteresis, high alarm set value, low alarm set value and zero alarm enable.

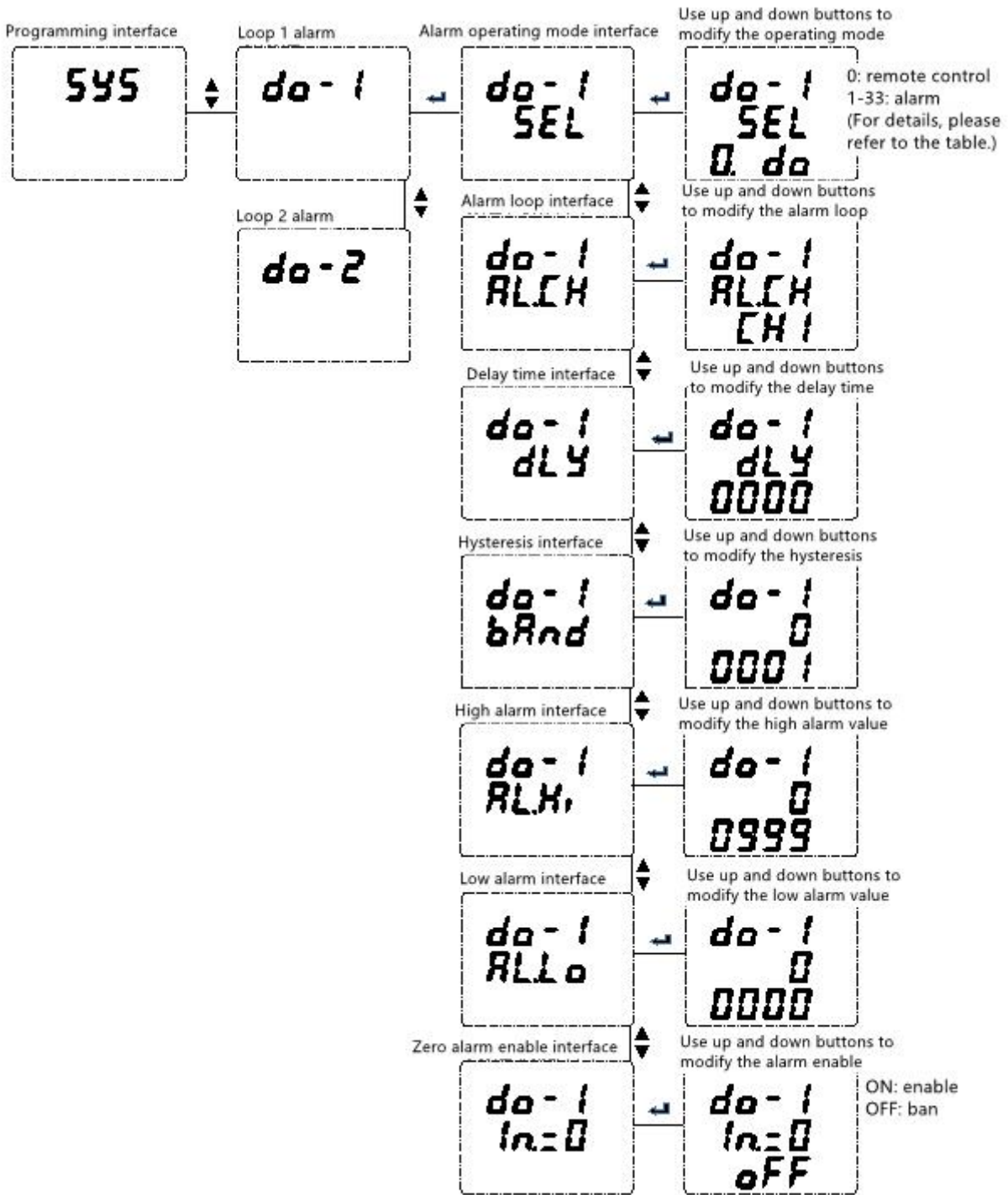

Table 6

<i>do.1</i>	The first switch							
<i>ALCH</i>	Circuit selection							
<i>SEL</i>	Alarm item setting							
	00	01	02	03	04	05	06	07
	Remote	UA	UB	UC	Phase voltage	UAB	UBC	UCA

	Control				maximum and minimum			
	08	09	10	11	12	13	14	
	Line voltage maximum and minimum	IA	IB	IC	Current maximum and minimum	PA	PB	
	15	16	17	18	19	20	21	22
	PC	P total	QA	QB	QC	Q total	SA	SB
	24	25	26	27	28	29	30	31
	S total	PFA	PFB	PFC	PF total	F	Voltage unbalance	Current unbalance
	32		33			34		
	DI1(linkage)		DI2(linkage)			Phase failure		
	"In. 0" of the corresponding channel needs to be set to "on".						The second DO can be set.	
<i>dLY</i>	When the alarm item SEL is 00 (remote control), DLY represents the duration after the switch action. When the alarm item SEL is not 00 (alarm), DLY represents the delay time before switching value action.							
<i>bAnd</i>	Alarm hysteresis							
<i>ALHi</i>	High alarm value setting (do not need to set the maximum 9999)							
<i>ALLo</i>	Low alarm value setting (do not need to set minimum 0)							
<i>In:0</i>	When the signal is 0 whether the low alarm is allowed. On is enabled. Off is disabled.							

#### 5.4.7 Save settings and exit

exit

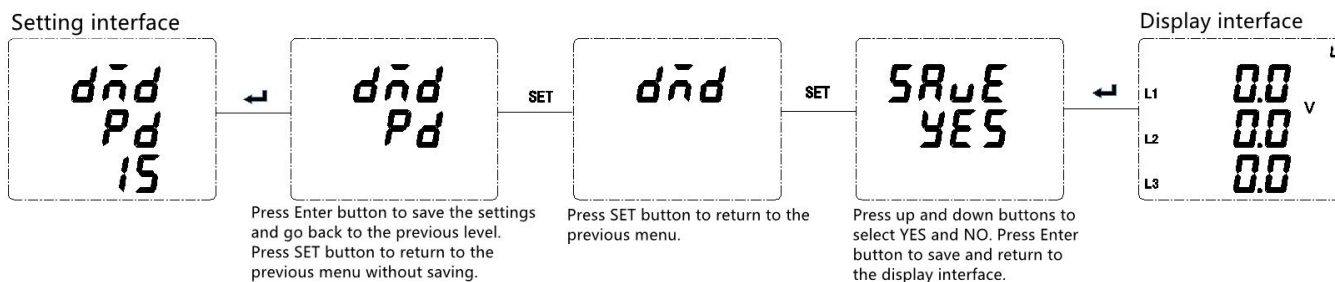

## 6 Communication description

### 6.1 Communication address

Word Address	Variate	Word Length	Read/Write	Unit	Data Type	Default	Remark
00H	Communication address	1	R/W		uint16_t	1	1-247
01H	Communication baud rate	1	R/W		uint16_t	3: 9600	0: 1200 1: 2400 2: 4800 3: 9600 4: 19200 5: 38400
02H	Communication	1	R/W		uint16_t	0	0:N 8 1 1:E 8 1 2:O 8 1 3:N 8 2

	check digit						
03H	Reservation	1	R/W				
04H	Reservation	1	R/W				
05H	Backlight Duration	1	R/W	S	uint16_t	30	0-250S, 0 means always bright
06H-07H	Host Send	2	R		uint32_t		
08H-09H	Reserved	2	R		uint32_t		
0AH-0BH	Reserved	2	R/W				
0CH	One degree electrical pulse number	1	R/W		uint16_t	1	1, 10, 100
0DH	Spreading factor	1	R/W		uint16_t	9	7-12
0EH	Channel	1	R/W		uint16_t	5	0-45
0FH	Wiring Method	1	R/W		uint16_t	0	0:3P4L 2:3P3L
10H	Clear Records	1	W		uint16_t		0x6401: Clear demand records 0x6402: Clear extreme value records 0x6403: Clear historical energy 0x6404: Clear frozen data 0x6405: Clear energy 0x6406: Clear multi-tariff rate energy 0x6407: clear event loggings
11H	Pulse constant	1	R		uint16_t	1600	1600-6400
12H	Power Pulse Selection	1	R/W		uint16_t	0	0:CH1 loop active energy pluse 1:CH2 loop active energy pluse 2:CH3 loop active energy pluse 3:CH4 loop active energy pluse 4: Clock pulse 5:CH1 loop active energy one pulse per kwh 6:CH2 loop active energy one pulse per kwh 7:CH3 loop active energy one pulse per kwh 8:CH4 loop active energy one pulse per kwh
13H	Primary side voltage rating	1	R/W	V	uint16_t	220	220-65000V
14H	CH1 primary side voltage rating	1	R/W	A	uint16_t	100	5-50000A
15H	CH2 primary side voltage rating	1	R/W	A	uint16_t	100	5-50000A
16H	CH3 primary side voltage rating	1	R/W	A	uint16_t	100	5-50000A
17H	CH4 primary side	1	R/W	A	uint16_t	100	5-50000A

	voltage rating						
18H	Secondary side current rating	1	R/W	A	uint16_t	100	100A、250A
19H	Secondary side voltage nominal value	1	R/W	V	uint16_t	220	220-65000V
1AH	Frequency nominal value	1	R/W	Hz	uint16_t	50	
1BH	Phase failure alarm set value	1	R/W	V	uint16_t	10	
1CH	Relay DO1 alarm selection circuit number	1	R/W		uint16_t	0	0x00:CH1 0x01:CH2 0x02:CH3 0x03:CH4
1DH	#1 Relay DO1 working mode	1	R/W		uint16_t	0	0: Remote control 1-34: Alarm (For details, see 5.4.6)
1EH	#1 Delay time	1	R/W	S	uint16_t	0	0-9999
1FH	#1 Alarm hysteresis	1	R/W		uint16_t	1	Consistent with the primary side rated value ratio
20H	#1 High alarm set point	1	R/W		uint16_t	999	Consistent with the primary side rated value ratio
21H	#1 Low alarm set point	1	R/W		uint16_t	0	Consistent with the primary side rated value ratio
22H	#1 Zero Alarm Enable	1	R/W		uint16_t	0	0: Ban 1: Enabled
23H-29H	#2 Relay DO2 configuration	7	R/W		uint16_t		Same as relay 1 setting
2AH	#DO1_S1	1	R/W				Switch module 1 relay state setting 0: Open 1: Close
2BH	#DO2_S1	1	R/W				
2CH	#DO3_S1	1	R/W				
2DH	#DO4_S1	1	R/W				
2EH	#DO1_S2	1	R/W				Switch module 2 relay state setting 0: Open 1: Close
2FH	#DO2_S2	1	R/W				
30H	#DO3_S2	1	R/W				
31H	#DO4_S2	1	R/W				
32H	Year/Month	1	R/W		uint16_t		
33H	Day/Week	1	R/W		uint16_t		
34H	Hour/Minute	1	R/W		uint16_t		
35H	Second/Reserved	1	R/W		uint16_t		
36H	D11	1	R/W		uint16_t		
37H	D12	1	R/W		uint16_t		
38H	Day Freeze Time	1	R/W		uint16_t	0x0016	High byte: Reserved Low byte: hour
39H	Demand work mode	1	R/W		uint16_t	0	0: Slip type 1: Fixed type
3AH	Demand slip time (t)	1	R/W		uint16_t	60	1-9999S
3BH	Demand calculation cycle (T)	1	R/W		uint16_t	15	1-30t

3CH	DO1	1	R/W		uint16_t		0: Open 1: Close
3DH	DO2	1	R/W		uint16_t		0: Open 1: Close
3EH	Reserved	1					
3FH-45H	..... The 1st time zone timetable number The 1st time zone start time: day The 1st time zone start time: month ..... The 4th time zone timetable number The 4th time zone start time: day The 4th time zone start time: month	3x4	R/W		uint8_t		Time slot number: 01 corresponds to the first set 02 corresponds to the second set
46H-5B H	..... The 1st set of timetables: The 1st period multi-tariff rate number The 1st period start time: minute The 1st period start time: hour ..... The 14th set of timetables: The 14th period tariff number The 14th period start time: minute The 14th period start time: hour	3x14	R/W		uint8_t		Multi-tariff rate number: 01 corresponds to sharp 02 corresponds to peak 03 corresponds to flat 04 corresponds to valley
5CH-70 H	..... The 2nd set of timetables: The 1st period multi-tariff rate number The 1st period start time: minute The 1st period start time: hour ..... The 14th set of timetables:	3x14	R/W		uint8_t		Multi-tariff rate number: 01 corresponds to sharp 02 corresponds to peak 03 corresponds to flat 04 corresponds to valley

	The 14th period tariff number The 14th period start time: minute The 14th period start time: hour						
71H	Meter reading day	1	R/W		uint16_t	0x1C13	Hour-Day
72H-78H	Meter serial number	7*2	R/W		Uint8_t	Acrel000001234	ASCII code
B0H	DI1	1	R		uint16_t		Passive switch
B1H	DI2	1	R		uint16_t		
B2H	DI3	1	R		uint16_t		
B3H	DI4	1	R		uint16_t		
B4H	DI5	1	R		uint16_t		Active switch
B5H	DI6	1	R		uint16_t		

#### Electricity parameters of circuit 1:

Address	Variate	Word Length	Read/Write	Unit	Data Type
100-101	CH1 A-phase voltage	2	R	V	float
102-103	CH1 B-phase voltage	2	R	V	float
104-105	CH1 C-phase voltage	2	R	V	float
106-107	CH1 AB line voltage	2	R	V	float
108-109	CH1 BC line voltage	2	R	V	float
10A-10B	CH1 CA line voltage	2	R	V	float
10C-10D	CH1 Frequency	2	R	Hz	float
10E-10F	CH1 A-phase current	2	R	A	float
110-111	CH1 B-phase current	2	R	A	float
112-113	CH1 C-phase current	2	R	A	float
114-115	CH1 Zero sequence current	2	R	A	float
116-117	CH1 A-phase active power	2	R	W	float
118-119	CH1 B-phase active power	2	R	W	float
11A-11B	CH1 C-phase active power	2	R	W	float
11C-11D	CH1 Total active power	2	R	W	float
11E-11F	CH1 A-phase reactive power	2	R	var	float
120-121	CH1 B-phase reactive power	2	R	var	float
122-123	CH1 C-phase reactive power	2	R	var	float
124-125	CH1 Total reactive power	2	R	var	float
126-127	CH1 A-phase apparent power	2	R	VA	float
128-129	CH1 B-phase apparent power	2	R	VA	float
12A-12B	CH1 C-phase apparent power	2	R	VA	float
12C-12D	CH1 Total apparent power	2	R	VA	float
12E-12F	CH1 A-phase power factor	2	R		float
130-131	CH1 B-phase power factor	2	R		float
132-133	CH1 C-phase power factor	2	R		float
134-135	CH1 Total power factor	2	R		float

136-137	CH1 A-phase positive active energy	2	R	kWh	float
138-139	CH1 B-phase positive active energy	2	R	kWh	float
13A-13B	CH1 C-phase positive active energy	2	R	kWh	float
13C-13D	CH1 Total positive active energy	2	R	kWh	float
13E-13F	CH1 A-phase negative active energy	2	R	kWh	float
140-141	CH1 B-phase negative active energy	2	R	kWh	float
142-143	CH1 C-phase negative active energy	2	R	kWh	float
144-145	CH1 Total negative active energy	2	R	kWh	float
146-147	CH1 A-phase positive reactive energy	2	R	kvarh	float
148-149	CH1 B-phase positive reactive energy	2	R	kvarh	float
14A-14B	CH1 C-phase positive reactive energy	2	R	kvarh	float
14C-14D	CH1 Total positive reactive energy	2	R	kvarh	float
14E-14F	CH1 A-phase negative reactive energy	2	R	kvarh	float
150-151	CH1 B-phase negative reactive energy	2	R	kvarh	float
152-153	CH1 C-phase negative reactive energy	2	R	kvarh	float
154-155	CH1 Total negative reactive energy	2	R	kvarh	float

**Power parameters of circuits 2, 3, 4: refer to the power parameters of circuit 1:**

156-157	CH2 A-phase voltage	1AC-1AD	CH3 A-phase voltage	202-203	CH4 A-phase voltage
158-159	CH2 B-phase voltage	1AE-1AF	CH3 B-phase voltage	204-205	CH4 B-phase voltage
15A-15B	CH2 C-phase voltage	1B0-1B1	CH3 C-phase voltage	206-207	CH4 C-phase voltage
15C-15D	CH2 AB line voltage	1B2-1B3	CH3 AB line voltage	208-209	CH4 AB line voltage
15E-15F	CH2 BC line voltage	1B4-1B5	CH3 BC line voltage	20A-20B	CH4 BC line voltage
160-161	CH2 CA line voltage	1B6-1B7	CH3 CA line voltage	20C-20D	CH4 CA line voltage
162-163	CH2 Frequency	1B8-1B9	CH3 Frequency	20E-20F	CH4 Frequency
164-165	CH2 A-phase current	1BA-1BB	CH3 A-phase current	210-211	CH4 A-phase current
166-167	CH2 B-phase current	1BC-1BD	CH3 B-phase current	212-213	CH4 B-phase current
168-169	CH2 C-phase current	1BE-1BF	CH3 C-phase current	214-215	CH4 C-phase current
16A-16B	CH2 Zero sequence current	1C0-1C1	CH3 Zero sequence current	216-217	CH4 Zero sequence current
16C-16D	CH2 A-phase active power	1C2-1C3	CH3 A-phase active power	218-219	CH4 A-phase active power
16E-16F	CH2 B-phase active power	1C4-1C5	CH3 B-phase active power	21A-21B	CH4 B-phase active power
170-171	CH2 C-phase active power	1C6-1C7	CH3 C-phase active power	21C-21D	CH4 C-phase active power
172-173	CH2 Total active power	1C8-1C9	CH3 Total active power	21E-21F	CH4 Total active power
174-175	CH2 A-phase reactive power	1CA-1CB	CH3 A-phase reactive power	220-221	CH4 A-phase reactive power
176-177	CH2 B-phase reactive power	1CC-1CD	CH3 B-phase reactive power	222-223	CH4 B-phase reactive power
178-179	CH2 C-phase reactive power	1CE-1CF	CH3 C-phase reactive power	224-225	CH4 C-phase reactive power
17A-17B	CH2 Total reactive power	1D0-1D1	CH3 Total reactive power	226-227	CH4 Total reactive power
17C-17D	CH2 A-phase apparent power	1D2-1D3	CH3 A-phase apparent power	228-229	CH4 A-phase apparent power

17E-17F	CH2 B-phase apparent power	1D4-1D5	CH3 B-phase apparent power	22A-22B	CH4 B-phase apparent power
180-181	CH2 C-phase apparent power	1D6-1D7	CH3 C-phase apparent power	22C-22D	CH4 C-phase apparent power
182-183	CH2 Total apparent power	1D8-1D9	CH3 Total apparent power	22E-22F	CH4 Total apparent power
184-185	CH2 A-phase power factor	1DA-1DB	CH3 A-phase power factor	230-231	CH4 A-phase power factor
186-187	CH2 B-phase power factor	1DC-1DD	CH3 B-phase power factor	232-233	CH4 B-phase power factor
188-189	CH2 C-phase power factor	1DE-1DF	CH3 C-phase power factor	234-235	CH4 C-phase power factor
18A-18B	CH2 Total power factor	1E0-1E1	CH3 Total power factor	236-237	CH4 Total power factor
18C-18D	CH2 A-phase positive active energy	1E2-1E3	CH3 A-phase positive active energy	238-239	CH4 A-phase positive active energy
18E-18F	CH2 B-phase positive active energy	1E4-1E5	CH3 B-phase positive active energy	23A-23B	CH4 B-phase positive active energy
190-191	CH2 C-phase positive active energy	1E6-1E7	CH3 C-phase positive active energy	23C-23D	CH4 C-phase positive active energy
192-193	CH2 Total positive active energy	1E8-1E9	CH3 Total positive active energy	23E-23F	CH4 Total positive active energy
194-195	CH2 A-phase negative active energy	1EA-1EB	CH3 A-phase negative active energy	240-241	CH4 A-phase negative active energy
196-197	CH2 B-phase negative active energy	1EC-1ED	CH3 B-phase negative active energy	242-243	CH4 B-phase negative active energy
198-199	CH2 C-phase negative active energy	1EE-1EF	CH3 C-phase negative active energy	244-245	CH4 C-phase negative active energy
19A-19B	CH2 Total negative active energy	1F0-1F1	CH3 Total negative active energy	246-247	CH4 Total negative active energy
19C-19D	CH2 A-phase positive reactive energy	1F2-1F3	CH3 A-phase positive reactive energy	248-249	CH4 A-phase positive reactive energy
19E-19F	CH2 B-phase positive reactive energy	1F4-1F5	CH3 B-phase positive reactive energy	24A-24B	CH4 B-phase positive reactive energy
1A0-1A1	CH2 C-phase positive reactive energy	1F6-1F7	CH3 C-phase positive reactive energy	24C-24D	CH4 C-phase positive reactive energy
1A2-1A3	CH2 Total positive reactive energy	1F8-1F9	CH3 Total positive reactive energy	24E-24F	CH4 Total positive reactive energy
1A4-1A5	CH2 A-phase negative reactive energy	1FA-1FB	CH3 A-phase negative reactive energy	250-251	CH4 A-phase negative reactive energy
1A6-1A7	CH2 B-phase negative reactive energy	1FC-1FD	CH3 B-phase negative reactive energy	252-253	CH4 B-phase negative reactive energy
1A8-1A9	CH2 C-phase negative reactive energy	1FE-1FF	CH3 C-phase negative reactive energy	254-255	CH4 C-phase negative reactive energy
1AA-1AB	CH2 Total negative reactive energy	200-201	CH3 Total negative reactive energy	256-257	CH4 Total negative reactive energy

Harmonic data:

Word Address	Variate	Word Length	R/W	Unit	Data Type	Remark
300-301	A-phase voltage phase angle	2	R		float	
302-303	B-phase voltage phase angle	2	R		float	
304-305	C-phase voltage phase angle	2	R		float	
306-307	CH1 A-phase current phase angle	2	R		float	
308-309	CH1 B-phase current phase angle	2	R		float	
30A-30B	CH1 C-phase current phase angle	2	R		float	
30C-30D	CH2 A-phase current phase angle	2	R		float	
30E-30F	CH2 B-phase current phase angle	2	R		float	
310-311	CH2 C-phase current phase angle	2	R		float	
312-313	CH3 A-phase current phase angle	2	R		float	
314-315	CH3 B-phase current phase angle	2	R		float	
316-317	CH3 C-phase current phase angle	2	R		float	
318-319	CH4 A-phase current phase angle	2	R		float	
31A-31B	CH4 B-phase current phase angle	2	R		float	
31C-31D	CH4 C-phase current phase angle	2	R		float	
31E-31F	Voltage unbalance	2	R		float	
320-321	CH1 Current unbalance	2	R		float	
322-323	CH2 Current unbalance	2	R		float	
324-325	CH3 Current unbalance	2	R		float	
326-327	CH4 Current unbalance	2	R		float	
328-329	A-phase voltage deviation	2	R		float	
32A-32B	B-phase voltage deviation	2	R		float	
32C-32D	C-phase voltage deviation	2	R		float	
32E-32F	AB line voltage deviation	2	R		float	
330-331	CB line voltage deviation	2	R		float	
332-333	CA line voltage deviation	2	R		float	
334-335	Frequency deviation	2	R		float	
336	A-phase voltage total harmonic distortion	1	R		int16_t	0.01%
337	B-phase voltage total harmonic distortion	1	R		int16_t	0.01%
338	C-phase voltage total harmonic distortion	1	R		int16_t	0.01%
339	CH1 A-phase current total harmonic distortion	1	R		int16_t	0.01%
33A	CH1 B-phase current total harmonic distortion	1	R		int16_t	0.01%
33B	CH1 C-phase current total harmonic distortion	1	R		int16_t	0.01%
33C	CH2 A-phase current total harmonic distortion	1	R		int16_t	0.01%
33D	CH2 B-phase current total harmonic distortion	1	R		int16_t	0.01%
33E	CH2 C-phase current total harmonic distortion	1	R		int16_t	0.01%
33F	CH3 A-phase current total harmonic distortion	1	R		int16_t	0.01%
340	CH3 B-phase current total harmonic distortion	1	R		int16_t	0.01%
341	CH3 C-phase current total harmonic distortion	1	R		int16_t	0.01%
342	CH4 A-phase current total harmonic distortion	1	R		int16_t	0.01%
343	CH4 B-phase current total harmonic distortion	1	R		int16_t	0.01%
344	CH4 C-phase current total harmonic distortion	1	R		int16_t	0.01%
345	A-phase voltage 2nd harmonic distortion rate	2	R		int16_t	0.01%
	B-phase voltage 2nd harmonic distortion rate	2	R		int16_t	0.01%

	C-phase voltage 2nd harmonic distortion rate	2	R		int16_t	0.01%
	.....	2	R		int16_t	0.01%
	A-phase voltage 31th harmonic distortion rate	2	R		int16_t	0.01%
	B-phase voltage 31th harmonic distortion rate	2	R		int16_t	0.01%
39E	C-phase voltage 31th harmonic distortion rate	2	R		int16_t	0.01%
39F	CH1 A-phase current 2nd harmonic distortion rate	2	R		int16_t	0.01%
	CH1 B-phase current 2nd harmonic distortion rate	2	R		int16_t	0.01%
	CH1 C-phase current 2nd harmonic distortion rate	2	R		int16_t	0.01%
	.....	2	R		int16_t	0.01%
	CH1 A-phase current 31th harmonic distortion rate	2	R		int16_t	0.01%
	CH1 B-phase current 31th harmonic distortion rate	2	R		int16_t	0.01%
3F8	CH1 C-phase current 31th harmonic distortion rate	2	R		int16_t	0.01%
3F9	CH2 A-phase current 2nd harmonic distortion rate	2	R		int16_t	0.01%
	CH2 B-phase current 2nd harmonic distortion rate	2	R		int16_t	0.01%
	CH2 C-phase current 2nd harmonic distortion rate	2	R		int16_t	0.01%
	.....	2	R		int16_t	0.01%
	CH2 A-phase current 31th harmonic distortion rate	2	R		int16_t	0.01%
	CH2 B-phase current 31th harmonic distortion rate	2	R		int16_t	0.01%
452	CH2 C-phase current 31th harmonic distortion rate	2	R		int16_t	0.01%
453	CH3 A-phase current 2nd harmonic distortion rate	2	R		int16_t	0.01%
	CH3 B-phase current 2nd harmonic distortion rate	2	R		int16_t	0.01%
	CH3 C-phase current 2nd harmonic distortion rate	2	R		int16_t	0.01%
	.....	2	R		int16_t	0.01%
	CH3 A-phase current 31th harmonic distortion rate	2	R		int16_t	0.01%
	CH3 B-phase current 31th harmonic distortion rate	2	R		int16_t	0.01%
4AC	CH3 C-phase current 31th harmonic distortion rate	2	R		int16_t	0.01%
4AD	CH4 A-phase current 2nd harmonic distortion rate	2	R		int16_t	0.01%
	CH4 B-phase current 2nd harmonic distortion rate	2	R		int16_t	0.01%
	CH4 C-phase current 2nd harmonic distortion rate	2	R		int16_t	0.01%
	.....	2	R		int16_t	0.01%
	CH4 A-phase current 31th harmonic distortion rate	2	R		int16_t	0.01%
	CH4 B-phase current 31th harmonic distortion rate	2	R		int16_t	0.01%
506	CH4 C-phase current 31th harmonic distortion rate	2	R		int16_t	0.01%

**Demand (save):**

Word Address	Variate (this month)	Word Length	R/W	Unit	Data Type	Remark	
1600-1601	CH1 A-phase current maximum monthly demand	2	R	A	float		
1602	Occurrence Time	1	R		uint16_t	Year	Month
1603		1	R		uint16_t	Day	Hour
1604		1	R		uint16_t	Minute	
1605-1606	CH1 B-phase current maximum monthly demand	2	R	A	float		
1607	Occurrence Time	1	R		uint16_t	Year	Month
1608		1	R		uint16_t	Day	Hour
1609		1	R		uint16_t	Minute	

160A-160B	CH1 C-phase current maximum monthly demand	2	R	A	float		
160C	Occurrence Time	1	R		uint16_t	Year	Month
160D		1	R		uint16_t	Day	Hour
160E		1	R		uint16_t	Minute	
160F-1610	CH1 A-phase power maximum monthly demand	2	R	W	float		
1611	Occurrence Time	1	R		uint16_t	Year	Month
1612		1	R		uint16_t	Day	Hour
1613		1	R		uint16_t	Minute	
1614-1615	CH1 B-phase power maximum monthly demand	2	R	W	float		
1616	Occurrence Time	1	R		uint16_t	Year	Month
1617		1	R		uint16_t	Day	Hour
1618		1	R		uint16_t	Minute	
1619-161A	CH1 C-phase power maximum monthly demand	2	R	W	float		
161B	Occurrence Time	1	R		uint16_t	Year	Month
161C		1	R		uint16_t	Day	Hour
161D		1	R		uint16_t	Minute	
161E-161F	CH1 Total power maximum monthly demand	2	R	W	float		
1620	Occurrence Time	1	R		uint16_t	Year	Month
1621		1	R		uint16_t	Day	Hour
1622		1	R		uint16_t	Minute	
1623-1624	CH2 A-phase current maximum monthly demand	2	R	A	float		
1625	Occurrence Time	1	R		uint16_t	Year	Month
1626		1	R		uint16_t	Day	Hour
1627		1	R		uint16_t	Minute	
1628-1629	CH2 B-phase current maximum monthly demand	2	R	A	float		
162A	Occurrence Time	1	R		uint16_t	Year	Month
162B		1	R		uint16_t	Day	Hour
162C		1	R		uint16_t	Minute	
162D-162E	CH2 C-phase current maximum monthly demand	2	R	A	float		
162F	Occurrence Time	1	R		uint16_t	Year	Month
1630		1	R		uint16_t	Day	Hour
1631		1	R		uint16_t	Minute	
1632-1633	CH2 A-phase power maximum monthly demand	2	R	W	float		
1634	Occurrence Time	1	R		uint16_t	Year	Month
1635		1	R		uint16_t	Day	Hour
1636		1	R		uint16_t	Minute	
1637-1638	CH2 B-phase power maximum	2	R	W	float		

	monthly demand						
1639	Occurrence Time	1	R		uint16_t	Year	Month
163A		1	R		uint16_t	Day	Hour
163B		1	R		uint16_t	Minute	
163C-163D	CH2 C-phase power maximum monthly demand	2	R	W	float		
163E	Occurrence Time	1	R		uint16_t	Year	Month
163F		1	R		uint16_t	Day	Hour
1640		1	R		uint16_t	Minute	
1641-1642	CH2 Total power maximum monthly demand	2	R	W	float		
1643	Occurrence Time	1	R		uint16_t	Year	Month
1644		1	R		uint16_t	Day	Hour
1645		1	R		uint16_t	Minute	
1646-1647	CH3 A-phase current maximum monthly demand	2	R	A	float		
1648	Occurrence Time	1	R		uint16_t	Year	Month
1649		1	R		uint16_t	Day	Hour
164A		1	R		uint16_t	Minute	
164B-164C	CH3 B-phase current maximum monthly demand	2	R	A	float		
164D	Occurrence Time	1	R		uint16_t	Year	Month
164E		1	R		uint16_t	Day	Hour
164F		1	R		uint16_t	Minute	
1650-1651	CH3 C-phase current maximum monthly demand	2	R	A	float		
1652	Occurrence Time	1	R		uint16_t	Year	Month
1653		1	R		uint16_t	Day	Hour
1654		1	R		uint16_t	Minute	
1655-1656	CH3 A-phase power maximum monthly demand	2	R	W	float		
1657	Occurrence Time	1	R		uint16_t	Year	Month
1658		1	R		uint16_t	Day	Hour
1659		1	R		uint16_t	Minute	
165A-165B	CH3 B-phase power maximum monthly demand	2	R	W	float		
165C	Occurrence Time	1	R		uint16_t	Year	Month
165D		1	R		uint16_t	Day	Hour
165E		1	R		uint16_t	Minute	
165F-1660	CH3 C-phase power maximum monthly demand	2	R	W	float		
1661	Occurrence Time	1	R		uint16_t	Year	Month
1662		1	R		uint16_t	Day	Hour
1663		1	R		uint16_t	Minute	
1664-1665	CH3 Total power maximum monthly demand	2	R	W	float		

1666	Occurrence Time	1	R		uint16_t	Year	Month
1667		1	R		uint16_t	Day	Hour
1668		1	R		uint16_t	Minute	
1669-166A	CH4 A-phase current maximum monthly demand	2	R	A	float		
166B	Occurrence Time	1	R		uint16_t	Year	Month
166C		1	R		uint16_t	Day	Hour
166D		1	R		uint16_t	Minute	
166E-166F	CH4 B-phase current maximum monthly demand	2	R	A	float		
1670	Occurrence Time	1	R		uint16_t	Year	Month
1671		1	R		uint16_t	Day	Hour
1672		1	R		uint16_t	Minute	
1673-1674	CH4 C-phase current maximum monthly demand	2	R	A	float		
1675	Occurrence Time	1	R		uint16_t	Year	Month
1676		1	R		uint16_t	Day	Hour
1677		1	R		uint16_t	Minute	
1678-1679	CH4 A-phase power maximum monthly demand	2	R	W	float		
167A	Occurrence Time	1	R		uint16_t	Year	Month
167B		1	R		uint16_t	Day	Hour
167C		1	R		uint16_t	Minute	
167D-167E	CH4 B-phase power maximum monthly demand	2	R	W	float		
167F	Occurrence Time	1	R		uint16_t	Year	Month
1680		1	R		uint16_t	Day	Hour
1681		1	R		uint16_t	Minute	
1682-1683	CH4 C-phase power maximum monthly demand	2	R	W	float		
1684	Occurrence Time	1	R		uint16_t	Year	Month
1685		1	R		uint16_t	Day	Hour
1686		1	R		uint16_t	Minute	
1687-1688	CH4 Total power maximum monthly demand	2	R	W	float		
1689	Occurrence Time	1	R		uint16_t	Year	Month
168A		1	R		uint16_t	Day	Hour
168B		1	R		uint16_t	Minute	

Word Address	Variate (last month)	Word Length	R/W	Unit	Data Type	Remark	
168C-168D	CH1 A-phase current maximum monthly demand	2	R	A	float		
168E	Occurrence Time	1	R		uint16_t	Year	Month
168F		1	R		uint16_t	Day	Hour
1690		1	R		uint16_t	Minute	

1691-1692	CH1 B-phase current maximum monthly demand	2	R	A	float		
1693	Occurrence Time	1	R		uint16_t	Year	Month
1694		1	R		uint16_t	Day	Hour
1695		1	R		uint16_t	Minute	
1696-1697	CH1 C-phase current maximum monthly demand	2	R	A	float		
1698	Occurrence Time	1	R		uint16_t	Year	Month
1699		1	R		uint16_t	Day	Hour
169A		1	R		uint16_t	Minute	
169B-169C	CH1 A-phase power maximum monthly demand	2	R	W	float		
169D	Occurrence Time	1	R		uint16_t	Year	Month
169E		1	R		uint16_t	Day	Hour
169F		1	R		uint16_t	Minute	
16A0-16A1	CH1 B-phase power maximum monthly demand	2	R	W	float		
16A2	Occurrence Time	1	R		uint16_t	Year	Month
16A3		1	R		uint16_t	Day	Hour
16A4		1	R		uint16_t	Minute	
16A5-16A6	CH1 C-phase power maximum monthly demand	2	R	W	float		
16A7	Occurrence Time	1	R		uint16_t	Year	Month
16A8		1	R		uint16_t	Day	Hour
16A9		1	R		uint16_t	Minute	
16AA-16AB	CH1 Total power maximum monthly demand	2	R	W	float		
16AC	Occurrence Time	1	R		uint16_t	Year	Month
16AD		1	R		uint16_t	Day	Hour
16AE		1	R		uint16_t	Minute	
16AF-16B0	CH2 A-phase current maximum monthly demand	2	R	A	float		
16B1	Occurrence Time	1	R		uint16_t	Year	Month
16B2		1	R		uint16_t	Day	Hour
16B3		1	R		uint16_t	Minute	
16B4-16B5	CH2 B-phase current maximum monthly demand	2	R	A	float		
16B6	Occurrence Time	1	R		uint16_t	Year	Month
16B7		1	R		uint16_t	Day	Hour
16B8		1	R		uint16_t	Minute	
16B9-16BA	CH2 C-phase current maximum monthly demand	2	R	A	float		
16BB	Occurrence Time	1	R		uint16_t	Year	Month
16BC		1	R		uint16_t	Day	Hour
16BD		1	R		uint16_t	Minute	
16BE-16BF	CH2 A-phase power maximum	2	R	W	float		

	monthly demand						
16C0	Occurrence Time	1	R		uint16_t	Year	Month
16C1		1	R		uint16_t	Day	Hour
16C2		1	R		uint16_t	Minute	
16C3-16C4	CH2 B-phase power maximum monthly demand	2	R	W	float		
16C5	Occurrence Time	1	R		uint16_t	Year	Month
16C6		1	R		uint16_t	Day	Hour
16C7		1	R		uint16_t	Minute	
16C8-16C9	CH2 C-phase power maximum monthly demand	2	R	W	float		
16CA	Occurrence Time	1	R		uint16_t	Year	Month
16CB		1	R		uint16_t	Day	Hour
16CC		1	R		uint16_t	Minute	
16CD-16CE	CH2 Total power maximum monthly demand	2	R	W	float		
16CF	Occurrence Time	1	R		uint16_t	Year	Month
16D0		1	R		uint16_t	Day	Hour
16D1		1	R		uint16_t	Minute	
16D2-16D3	CH3 A-phase current maximum monthly demand	2	R	A	float		
16D4	Occurrence Time	1	R		uint16_t	Year	Month
16D5		1	R		uint16_t	Day	Hour
16D6		1	R		uint16_t	Minute	
16D7-16D8	CH3 B-phase current maximum monthly demand	2	R	A	float		
16D9	Occurrence Time	1	R		uint16_t	Year	Month
16DA		1	R		uint16_t	Day	Hour
16DB		1	R		uint16_t	Minute	
16DC-16DD	CH3 C-phase current maximum monthly demand	2	R	A	float		
16DE	Occurrence Time	1	R		uint16_t	Year	Month
16DF		1	R		uint16_t	Day	Hour
16E0		1	R		uint16_t	Minute	
16E1-16E2	CH3 A-phase power maximum monthly demand	2	R	W	float		
16E3	Occurrence Time	1	R		uint16_t	Year	Month
16E4		1	R		uint16_t	Day	Hour
16E5		1	R		uint16_t	Minute	
16E6-16E7	CH3 B-phase power maximum monthly demand	2	R	W	float		
16E8	Occurrence Time	1	R		uint16_t	Year	Month
16E9		1	R		uint16_t	Day	Hour
16EA		1	R		uint16_t	Minute	
16EB-16EC	CH3 C-phase power maximum monthly demand	2	R	W	float		

16ED	Occurrence Time	1	R		uint16_t	Year	Month
16EE		1	R		uint16_t	Day	Hour
16EF		1	R		uint16_t	Minute	
16F0-16F1	CH3 Total power maximum monthly demand	2	R	W	float		
16F2	Occurrence Time	1	R		uint16_t	Year	Month
16F3		1	R		uint16_t	Day	Hour
16F4		1	R		uint16_t	Minute	
16F5-16F6	CH4 A-phase current maximum monthly demand	2	R	A	float		
16F7	Occurrence Time	1	R		uint16_t	Year	Month
16F8		1	R		uint16_t	Day	Hour
16F9		1	R		uint16_t	Minute	
16FA-16FB	CH4 B-phase current maximum monthly demand	2	R	A	float		
16FC	Occurrence Time	1	R		uint16_t	Year	Month
16FD		1	R		uint16_t	Day	Hour
16FE		1	R		uint16_t	Minute	
16FF-1700	CH4 C-phase current maximum monthly demand	2	R	A	float		
1701	Occurrence Time	1	R		uint16_t	Year	Month
1702		1	R		uint16_t	Day	Hour
1703		1	R		uint16_t	Minute	
1704-1705	CH4 A-phase power maximum monthly demand	2	R	W	float		
1706	Occurrence Time	1	R		uint16_t	Year	Month
1707		1	R		uint16_t	Day	Hour
1708		1	R		uint16_t	Minute	
1709-170A	CH4 B-phase power maximum monthly demand	2	R	W	float		
170B	Occurrence Time	1	R		uint16_t	Year	Month
170C		1	R		uint16_t	Day	Hour
170D		1	R		uint16_t	Minute	
170E-170F	CH4 C-phase power maximum monthly demand	2	R	W	float		
1710	Occurrence Time	1	R		uint16_t	Year	Month
1711		1	R		uint16_t	Day	Hour
1712		1	R		uint16_t	Minute	
1713-1714	CH4 Total power maximum monthly demand	2	R	W	float		
1715	Occurrence Time	1	R		uint16_t	Year	Month
1716		1	R		uint16_t	Day	Hour
1717		1	R		uint16_t	Minute	

Serial Number	Word Address	Variate	Word Length	R/W	Unit	Data Type	Remark
---------------	--------------	---------	-------------	-----	------	-----------	--------

1718-1719	CH1 Current demand of A-phase current	2	R	A	float		
171A-171B	CH1 Current demand of B-phase current	2	R	A	float		
171C-171D	CH1 Current demand of C-phase current	2	R	A	float		
171E-171F	CH1 Current demand of A-phase power	2	R	W	float		
1720-1721	CH1 Current demand of B-phase power	2	R	W	float		
1722-1723	CH1 Current demand of C-phase power	2	R	W	float		
1724-1725	CH1 Current demand of power	2	R	W	float		
1726-1727	CH2 Current demand of A-phase current	2	R	A	float		
1728-1729	CH2 Current demand of B-phase current	2	R	A	float		
172A-172B	CH2 Current demand of C-phase current	2	R	A	float		
172C-172D	CH2 Current demand of A-phase power	2	R	W	float		
172E-172F	CH2 Current demand of B-phase power	2	R	W	float		
1730-1731	CH2 Current demand of C-phase power	2	R	W	float		
1732-1733	CH2 Current demand of power	2	R	W	float		
1734-1735	CH3 Current demand of A-phase current	2	R	A	float		
1736-1737	CH3 Current demand of B-phase current	2	R	A	float		
1738-1739	CH3 Current demand of C-phase current	2	R	A	float		
173A-173B	CH3 Current demand of A-phase power	2	R	W	float		
173C-173D	CH3 Current demand of B-phase power	2	R	W	float		
173E-173F	CH3 Current demand of C-phase power	2	R	W	float		
1740-1741	CH3 Current demand of power	2	R	W	float		
1742-1743	CH4 Current demand of A-phase current	2	R	A	float		
1744-1745	CH4 Current demand of B-phase current	2	R	A	float		
1746-1747	CH4 Current demand of C-phase current	2	R	A	float		
1748-1749	CH4 Current demand of A-phase power	2	R	W	float		
174A-174B	CH4 Current demand of B-phase power	2	R	W	float		
174C-174D	CH4 Current demand of C-phase power	2	R	W	float		
174E-174F	CH4 Current demand of power	2	R	W	float		

**Total multi-tariff rate energy for loops 1-4 (saved):**

Word Address	Variate	Word Length	R/W	Unit	Data Type	Remark
600-601	CH1 Total multi-tariff rate energy	2	R	kWh	Float	
602-603	CH1 Total multi-tariff rate energy [sharp]	2	R	kWh	Float	
604-605	CH1 Total multi-tariff rate energy [peak]	2	R	kWh	Float	
606-607	CH1 Total multi-tariff rate energy [flat]	2	R	kWh	Float	
608-609	CH1 Total multi-tariff rate energy [valley]	2	R	kWh	Float	
60A-60B	CH2 Total multi-tariff rate energy	2	R	kWh	Float	
60C-60D	CH2 Total multi-tariff rate energy [sharp]	2	R	kWh	Float	
60E-60F	CH2 Total multi-tariff rate energy [peak]	2	R	kWh	Float	
610-611	CH2 Total multi-tariff rate energy [flat]	2	R	kWh	Float	
612-613	CH2 Total multi-tariff rate energy [valley]	2	R	kWh	Float	
614-615	CH3 Total multi-tariff rate energy	2	R	kWh	Float	
616-617	CH3 Total multi-tariff rate energy [sharp]	2	R	kWh	Float	

618-619	CH3 Total multi-tariff rate energy [peak]	2	R	kWh	Float	
61A-61B	CH3 Total multi-tariff rate energy [flat]	2	R	kWh	Float	
61C-61D	CH3 Total multi-tariff rate energy [valley]	2	R	kWh	Float	
61E-61F	CH4 Total multi-tariff rate energy	2	R	kWh	Float	
620-621	CH4 Total multi-tariff rate energy [sharp]	2	R	kWh	Float	
622-623	CH4 Total multi-tariff rate energy [peak]	2	R	kWh	Float	
624-625	CH4 Total multi-tariff rate energy [flat]	2	R	kWh	Float	
626-627	CH4 Total multi-tariff rate energy [valley]	2	R	kWh	Float	

For the multi-tariff rate energy from January to December, refer to the total multi-tariff rate energy of loops 1-4 in the above table:

Word Address	Variate	Word Address	Variate
628-629	CH1 Total multi-tariff rate energy in last January	650-651	CH1 Total multi-tariff rate energy in last February
62A-62B	CH1 Total multi-tariff rate energy in last January [sharp]	652-653	CH1 Total multi-tariff rate energy in last February [sharp]
62C-62D	CH1 Total multi-tariff rate energy in last January [peak]	654-655	CH1 Total multi-tariff rate energy in last February [peak]
62E-62F	CH1 Total multi-tariff rate energy in last January [flat]	656-657	CH1 Total multi-tariff rate energy in last February [flat]
630-631	CH1 Total multi-tariff rate energy in last January [valley]	658-659	CH1 Total multi-tariff rate energy in last February [valley]
632-633	CH2 Total multi-tariff rate energy in last January	65A-65B	CH2 Total multi-tariff rate energy in last February
634-635	CH2 Total multi-tariff rate energy in last January [sharp]	65C-65D	CH2 Total multi-tariff rate energy in last February [sharp]
636-637	CH2 Total multi-tariff rate energy in last January [peak]	65E-65F	CH2 Total multi-tariff rate energy in last February [peak]
638-639	CH2 Total multi-tariff rate energy in last January [flat]	660-661	CH2 Total multi-tariff rate energy in last February [flat]
63A-63B	CH2 Total multi-tariff rate energy in last January [valley]	662-663	CH2 Total multi-tariff rate energy in last February [valley]
63C-63D	CH3 Total multi-tariff rate energy in last January	664-665	CH3 Total multi-tariff rate energy in last February
63E-63F	CH3 Total multi-tariff rate energy in last January [sharp]	666-667	CH3 Total multi-tariff rate energy in last February [sharp]
640-641	CH3 Total multi-tariff rate energy in last January [peak]	668-669	CH3 Total multi-tariff rate energy in last February [peak]
642-643	CH3 Total multi-tariff rate energy in last January [flat]	66A-66B	CH3 Total multi-tariff rate energy in last February [flat]
644-645	CH3 Total multi-tariff rate energy in last January [valley]	66C-66D	CH3 Total multi-tariff rate energy in last February [valley]
646-647	CH4 Total multi-tariff rate energy in last January	66E-66F	CH4 Total multi-tariff rate energy in last February
648-649	CH4 Total multi-tariff rate energy in last January	670-671	CH4 Total multi-tariff rate energy in last February

	[sharp]		February [sharp]
64A-64B	CH4 Total multi-tariff rate energy in last January [peak]	672-673	CH4 Total multi-tariff rate energy in last February [peak]
64C-64D	CH4 Total multi-tariff rate energy in last January [flat]	674-675	CH4 Total multi-tariff rate energy in last February [flat]
64E-64F	CH4 Total multi-tariff rate energy in last January [valley]	676-677	CH4 Total multi-tariff rate energy in last February [valley]
678-679	CH1 Total multi-tariff rate energy in last March	6A0-6A1	CH1 Total multi-tariff rate energy in last April
67A-67B	CH1 Total multi-tariff rate energy in last March [sharp]	6A2-6A3	CH1 Total multi-tariff rate energy in last April [sharp]
67C-67D	CH1 Total multi-tariff rate energy in last March [peak]	6A4-6A5	CH1 Total multi-tariff rate energy in last April [peak]
67E-67F	CH1 Total multi-tariff rate energy in last March [flat]	6A6-6A7	CH1 Total multi-tariff rate energy in last April [flat]
680-681	CH1 Total multi-tariff rate energy in last March [valley]	6A8-6A9	CH1 Total multi-tariff rate energy in last April [valley]
682-683	CH2 Total multi-tariff rate energy in last March	6AA-6AB	CH2 Total multi-tariff rate energy in last April
684-685	CH2 Total multi-tariff rate energy in last March [sharp]	6AC-6AD	CH2 Total multi-tariff rate energy in last April [sharp]
686-687	CH2 Total multi-tariff rate energy in last March [peak]	6AE-6AF	CH2 Total multi-tariff rate energy in last April [peak]
688-689	CH2 Total multi-tariff rate energy in last March [flat]	6B0-6B1	CH2 Total multi-tariff rate energy in last April [flat]
68A-68B	CH2 Total multi-tariff rate energy in last March [valley]	6B2-6B3	CH2 Total multi-tariff rate energy in last April [valley]
68C-68D	CH3 Total multi-tariff rate energy in last March	6B4-6B5	CH3 Total multi-tariff rate energy in last April
68E-68F	CH3 Total multi-tariff rate energy in last March [sharp]	6B6-6B7	CH3 Total multi-tariff rate energy in last April [sharp]
690-691	CH3 Total multi-tariff rate energy in last March [peak]	6B8-6B9	CH3 Total multi-tariff rate energy in last April [peak]
692-693	CH3 Total multi-tariff rate energy in last March [flat]	6BA-6BB	CH3 Total multi-tariff rate energy in last April [flat]
694-695	CH3 Total multi-tariff rate energy in last March [valley]	6BC-6BD	CH3 Total multi-tariff rate energy in last April [valley]
696-697	CH4 Total multi-tariff rate energy in last March	6BE-6BF	CH4 Total multi-tariff rate energy in last April
698-699	CH4 Total multi-tariff rate energy in last March [sharp]	6C0-6C1	CH4 Total multi-tariff rate energy in last April [sharp]
69A-69B	CH4 Total multi-tariff rate energy in last March [peak]	6C2-6C3	CH4 Total multi-tariff rate energy in last April [peak]
69C-69D	CH4 Total multi-tariff rate energy in last March [flat]	6C4-6C5	CH4 Total multi-tariff rate energy in last April [flat]
69E-69F	CH4 Total multi-tariff rate energy in last March [valley]	6C6-6C7	CH4 Total multi-tariff rate energy in last April [valley]
6C8-6C9	CH1 Total multi-tariff rate energy in last May	6F0-6F1	CH1 Total multi-tariff rate energy in last June
6CA-6CB	CH1 Total multi-tariff rate energy in last May [sharp]	6F2-6F3	CH1 Total multi-tariff rate energy in last June [sharp]

6CC-6CD	CH1 Total multi-tariff rate energy in last May [peak]	6F4-6F5	CH1 Total multi-tariff rate energy in last June [peak]
6CE-6CF	CH1 Total multi-tariff rate energy in last May [flat]	6F6-6F7	CH1 Total multi-tariff rate energy in last June [flat]
6D0-6D1	CH1 Total multi-tariff rate energy in last May [valley]	6F8-6F9	CH1 Total multi-tariff rate energy in last June [valley]
6D2-6D3	CH2 Total multi-tariff rate energy in last May	6FA-6FB	CH2 Total multi-tariff rate energy in last June
6D4-6D5	CH2 Total multi-tariff rate energy in last May [sharp]	6FC-6FD	CH2 Total multi-tariff rate energy in last June [sharp]
6D6-6D7	CH2 Total multi-tariff rate energy in last May [peak]	6FE-6FF	CH2 Total multi-tariff rate energy in last June [peak]
6D8-6D9	CH2 Total multi-tariff rate energy in last May [flat]	700-701	CH2 Total multi-tariff rate energy in last June [flat]
6DA-6DB	CH2 Total multi-tariff rate energy in last May [valley]	702-703	CH2 Total multi-tariff rate energy in last June [valley]
6DC-6DD	CH3 Total multi-tariff rate energy in last May	704-705	CH3 Total multi-tariff rate energy in last June
6DE-6DF	CH3 Total multi-tariff rate energy in last May [sharp]	706-707	CH3 Total multi-tariff rate energy in last June [sharp]
6E0-6E1	CH3 Total multi-tariff rate energy in last May [peak]	708-709	CH3 Total multi-tariff rate energy in last June [peak]
6E2-6E3	CH3 Total multi-tariff rate energy in last May [flat]	70A-70B	CH3 Total multi-tariff rate energy in last June [flat]
6E4-6E5	CH3 Total multi-tariff rate energy in last May [valley]	70C-70D	CH3 Total multi-tariff rate energy in last June [valley]
6E6-6E7	CH4 Total multi-tariff rate energy in last May	70E-70F	CH4 Total multi-tariff rate energy in last June
6E8-6E9	CH4 Total multi-tariff rate energy in last May [sharp]	710-711	CH4 Total multi-tariff rate energy in last June [sharp]
6EA-6EB	CH4 Total multi-tariff rate energy in last May [peak]	712-713	CH4 Total multi-tariff rate energy in last June [peak]
6EC-6ED	CH4 Total multi-tariff rate energy in last May [flat]	714-715	CH4 Total multi-tariff rate energy in last June [flat]
6EE-6EF	CH4 Total multi-tariff rate energy in last May [valley]	716-717	CH4 Total multi-tariff rate energy in last June [valley]
718-719	CH1 Total multi-tariff rate energy in last July	740-741	CH1 Total multi-tariff rate energy in last August
71A-71B	CH1 Total multi-tariff rate energy in last July [sharp]	742-743	CH1 Total multi-tariff rate energy in last August [sharp]
71C-71D	CH1 Total multi-tariff rate energy in last July [peak]	744-745	CH1 Total multi-tariff rate energy in last August [peak]
71E-71F	CH1 Total multi-tariff rate energy in last July [flat]	746-747	CH1 Total multi-tariff rate energy in last August [flat]
720-721	CH1 Total multi-tariff rate energy in last July [valley]	748-749	CH1 Total multi-tariff rate energy in last August [valley]
722-723	CH2 Total multi-tariff rate energy in last July	74A-74B	CH2 Total multi-tariff rate energy in last August
724-725	CH2 Total multi-tariff rate energy in last July [sharp]	74C-74D	CH2 Total multi-tariff rate energy in last August [sharp]
726-727	CH2 Total multi-tariff rate energy in last July	74E-74F	CH2 Total multi-tariff rate energy in last August

	[peak]		[peak]
728-729	CH2 Total multi-tariff rate energy in last July [flat]	750-751	CH2 Total multi-tariff rate energy in last August [flat]
72A-72B	CH2 Total multi-tariff rate energy in last July [valley]	752-753	CH2 Total multi-tariff rate energy in last August [valley]
72C-72D	CH3 Total multi-tariff rate energy in last July	754-755	CH3 Total multi-tariff rate energy in last August
72E-72F	CH3 Total multi-tariff rate energy in last July [sharp]	756-757	CH3 Total multi-tariff rate energy in last August [sharp]
730-731	CH3 Total multi-tariff rate energy in last July [peak]	758-759	CH3 Total multi-tariff rate energy in last August [peak]
732-733	CH3 Total multi-tariff rate energy in last July [flat]	75A-75B	CH3 Total multi-tariff rate energy in last August [flat]
734-735	CH3 Total multi-tariff rate energy in last July [valley]	75C-75D	CH3 Total multi-tariff rate energy in last August [valley]
736-737	CH4 Total multi-tariff rate energy in last July	75E-75F	CH4 Total multi-tariff rate energy in last August
738-739	CH4 Total multi-tariff rate energy in last July [sharp]	760-761	CH4 Total multi-tariff rate energy in last August [sharp]
73A-73B	CH4 Total multi-tariff rate energy in last July [peak]	762-763	CH4 Total multi-tariff rate energy in last August [peak]
73C-73D	CH4 Total multi-tariff rate energy in last July [flat]	764-765	CH4 Total multi-tariff rate energy in last August [flat]
73E-73F	CH4 Total multi-tariff rate energy in last July [valley]	766-767	CH4 Total multi-tariff rate energy in last August [valley]
768-769	CH1 Total multi-tariff rate energy in last September	790-791	CH1 Total multi-tariff rate energy in last October
76A-76B	CH1 Total multi-tariff rate energy in last September [sharp]	792-793	CH1 Total multi-tariff rate energy in last October [sharp]
76C-76D	CH1 Total multi-tariff rate energy in last September [peak]	794-795	CH1 Total multi-tariff rate energy in last October [peak]
76E-76F	CH1 Total multi-tariff rate energy in last September [flat]	796-797	CH1 Total multi-tariff rate energy in last October [flat]
770-771	CH1 Total multi-tariff rate energy in last September [valley]	798-799	CH1 Total multi-tariff rate energy in last October [valley]
772-773	CH2 Total multi-tariff rate energy in last September	79A-79B	CH2 Total multi-tariff rate energy in last October
774-775	CH2 Total multi-tariff rate energy in last September [sharp]	79C-79D	CH2 Total multi-tariff rate energy in last October [sharp]
776-777	CH2 Total multi-tariff rate energy in last September [peak]	79E-79F	CH2 Total multi-tariff rate energy in last October [peak]
778-779	CH2 Total multi-tariff rate energy in last September [flat]	7A0-7A1	CH2 Total multi-tariff rate energy in last October [flat]
77A-77B	CH2 Total multi-tariff rate energy in last September [valley]	7A2-7A3	CH2 Total multi-tariff rate energy in last October [valley]
77C-77D	CH3 Total multi-tariff rate energy in last September	7A4-7A5	CH3 Total multi-tariff rate energy in last October
77E-77F	CH3 Total multi-tariff rate energy in last	7A6-7A7	CH3 Total multi-tariff rate energy in last October

	September [sharp]		[sharp]
780-781	CH3 Total multi-tariff rate energy in last September [peak]	7A8-7A9	CH3 Total multi-tariff rate energy in last October [peak]
782-783	CH3 Total multi-tariff rate energy in last September [flat]	7AA-7AB	CH3 Total multi-tariff rate energy in last October [flat]
784-785	CH3 Total multi-tariff rate energy in last September [valley]	7AC-7AD	CH3 Total multi-tariff rate energy in last October [valley]
786-787	CH4 Total multi-tariff rate energy in last September	7AE-7AF	CH4 Total multi-tariff rate energy in last October
788-789	CH4 Total multi-tariff rate energy in last September [sharp]	7B0-7B1	CH4 Total multi-tariff rate energy in last October [sharp]
78A-78B	CH4 Total multi-tariff rate energy in last September [peak]	7B2-7B3	CH4 Total multi-tariff rate energy in last October [peak]
78C-78D	CH4 Total multi-tariff rate energy in last September [flat]	7B4-7B5	CH4 Total multi-tariff rate energy in last October [flat]
78E-78F	CH4 Total multi-tariff rate energy in last September [valley]	7B6-7B7	CH4 Total multi-tariff rate energy in last October [valley]
7B8-7B9	CH1 Total multi-tariff rate energy in last November	7E0-7E1	CH1 Total multi-tariff rate energy in last December
7BA-7BB	CH1 Total multi-tariff rate energy in last November [sharp]	7E2-7E3	CH1 Total multi-tariff rate energy in last December [sharp]
7BC-7BD	CH1 Total multi-tariff rate energy in last November [peak]	7E4-7E5	CH1 Total multi-tariff rate energy in last December [peak]
7BE-7BF	CH1 Total multi-tariff rate energy in last November [flat]	7E6-7E7	CH1 Total multi-tariff rate energy in last December [flat]
7C0-7C1	CH1 Total multi-tariff rate energy in last November [valley]	7E8-7E9	CH1 Total multi-tariff rate energy in last December [valley]
7C2-7C3	CH2 Total multi-tariff rate energy in last November	7EA-7EB	CH2 Total multi-tariff rate energy in last December
7C4-7C5	CH2 Total multi-tariff rate energy in last November [sharp]	7EC-7ED	CH2 Total multi-tariff rate energy in last December [sharp]
7C6-7C7	CH2 Total multi-tariff rate energy in last November [peak]	7EE-7EF	CH2 Total multi-tariff rate energy in last December [peak]
7C8-7C9	CH2 Total multi-tariff rate energy in last November [flat]	7F0-7F1	CH2 Total multi-tariff rate energy in last December [flat]
7CA-7CB	CH2 Total multi-tariff rate energy in last November [valley]	7F2-7F3	CH2 Total multi-tariff rate energy in last December [valley]
7CC-7CD	CH3 Total multi-tariff rate energy in last November	7F4-7F5	CH3 Total multi-tariff rate energy in last December
7CE-7CF	CH3 Total multi-tariff rate energy in last November [sharp]	7F6-7F7	CH3 Total multi-tariff rate energy in last December [sharp]
7D0-7D1	CH3 Total multi-tariff rate energy in last November [peak]	7F8-7F9	CH3 Total multi-tariff rate energy in last December [peak]
7D2-7D3	CH3 Total multi-tariff rate energy in last November [flat]	7FA-7FB	CH3 Total multi-tariff rate energy in last December [flat]
7D4-7D5	CH3 Total multi-tariff rate energy in last	7FC-7FD	CH3 Total multi-tariff rate energy in last

	November [valley]		December [valley]
7D6-7D7	CH4 Total multi-tariff rate energy in last November	7FE-7FF	CH4 Total multi-tariff rate energy in last December
7D8-7D9	CH4 Total multi-tariff rate energy in last November [sharp]	800-801	CH4 Total multi-tariff rate energy in last December [sharp]
7DA-7DB	CH4 Total multi-tariff rate energy in last November [peak]	802-803	CH4 Total multi-tariff rate energy in last December [peak]
7DC-7DD	CH4 Total multi-tariff rate energy in last November [flat]	804-805	CH4 Total multi-tariff rate energy in last December [flat]
7DE-7DF	CH4 Total multi-tariff rate energy in last November [valley]	806-807	CH4 Total multi-tariff rate energy in last December [valley]

### CH1 extreme value and occurrence time

Word Address	Variate	Word Length	R/W	Unit	Data Type	Remark	
900-901	This month A-phase voltage maximum value	2	R	V	float		
902	This month A-phase voltage maximum value and occurrence time	1	R		uint16_t	Year	Month
903		1	R		uint16_t	Day	Hour
904		1	R		uint16_t	Minute	Second
905-909	This month B-phase voltage maximum value and occurrence time	5	R				
90A-90E	This month C-phase voltage maximum value and occurrence time	5	R				
90F-913	This month AB line voltage maximum value and occurrence time	5	R				
914-918	This month BC line voltage maximum value and occurrence time	5	R				
919-91D	This month CA line voltage maximum value and occurrence time	5	R				
91E-922	This month A-phase voltage minimum value and occurrence time	5	R				
923-927	This month B-phase voltage minimum value and occurrence time	5	R				
928-92C	This month C-phase voltage minimum value and occurrence time	5	R				
92D-931	This month AB line voltage minimum value and occurrence time	5	R				
932-936	This month BC line voltage minimum value and occurrence time	5	R				
937-93B	This month CA line voltage minimum value and occurrence time	5	R				
9B4-9B5	This month CH1 A-phase current maximum value	2	R	A	float		
9B6	This month occurrence time of CH1A current maximum value	1	R		uint16_t	Year	Month
9B7		1	R		uint16_t	Day	Hour
9B8		1	R		uint16_t	Minute	Second
9B9-9BD	This month CH1 B-phase current maximum	5	R				

	value						
9BE-9C2	This month CH1 C-phase current maximum value	5	R				
9C3-9C7	This month CH1 Zero sequence current maximum value	5	R				
9C8-9CC	This month CH1 A-phase active power maximum value	5	R				
9CD-9D1	This month CH1 B-phase active power maximum value	5	R				
9D2-9D6	This month CH1 C-phase active power maximum value	5	R				
9D7-9DB	This month CH1 active power maximum value	5	R				
9DC-9E0	This month CH1 A-phase reactive power maximum value	5	R				
9E1-9E5	This month CH1 B-phase reactive power maximum value	5	R				
9E6-9EA	This month CH1 C-phase reactive power maximum value	5	R				
9EB-9EF	This month CH1 reactive power maximum value	5	R				
9F0-9F4	This month CH1 A-phase apparent power maximum value	5	R				
9F5-9F9	This month CH1 B-phase apparent power maximum value	5	R				
9FA-9FE	This month CH1 C-phase apparent power maximum value	5	R				
9FF-A03	This month CH1 apparent power maximum value	5	R				
A04-A08	This month CH1 A-phase power factor maximum value	5	R				
A09-A0D	This month CH1 B-phase power factor maximum value	5	R				
A0E-A12	This month CH1 C-phase power factor maximum value	5	R				
A13-A17	This month CH1 power factor maximum value	5	R				
A18-A1C	This month CH1 load rate maximum value	5	R				
A86-A87	This month CH1 A-phase current minimum value	2	R	A	float		
A88	This month occurrence time of CH1 A current minimum value	1	R		uint16_t	Year	Month
A89		1	R		uint16_t	Day	Hour
A8A		1	R		uint16_t	Minute	Second
A8B-A8F	This month CH1 B-phase current minimum value	5	R				
A90-A94	This month CH1 C-phase current minimum value	5	R				
A95-A99	This month CH1 Zero sequence current	5	R				

	minimum value						
A9A-A9E	This month CH1 A-phase active power minimum value	5	R				
A9F-AA3	This month CH1 B-phase active power minimum value	5	R				
AA4-AA8	This month CH1 C-phase active power minimum value	5	R				
AA9-AAD	This month CH1 active power minimum value	5	R				
AAE-AB2	This month CH1 A-phase reactive power minimum value	5	R				
AB3-AB7	This month CH1 B-phase reactive power minimum value	5	R				
AB8-ABC	This month CH1 C-phase reactive power minimum value	5	R				
ABD-AC1	This month CH1 reactive power minimum value	5	R				
AC2-AC6	This month CH1 A-phase apparent power minimum value	5	R				
AC7-ACB	This month CH1 B-phase apparent power minimum value	5	R				
ACC-AD0	This month CH1 C-phase apparent power minimum value	5	R				
AD1-AD5	This month CH1 apparent power minimum value	5	R				
AD6-ADA	This month CH1 A-phase power factor minimum value	5	R				
ADB-ADF	This month CH1 B-phase power factor minimum value	5	R				
AE0-AE4	This month CH1 C-phase power factor minimum value	5	R				
AE5-AE9	This month CH1 power factor minimum value	5	R				
AEA-AEE	This month CH1 load rate minimum value	5	R				
95A-95B	Last month A-phase voltage maximum value	2	R	V	float		
95C	Last month occurrence time of A-phase current maximum value	1	R		uint16_t	Year	Month
95D		1	R		uint16_t	Day	Hour
95E		1	R		uint16_t	Minute	Second
95F-963	Last month B-phase voltage maximum value	5	R				
964-968	Last month C-phase voltage maximum value	5	R				
969-96D	Last month AB line voltage maximum value	5	R				
96E-972	Last month BC line voltage maximum value	5	R				
973-977	Last month CA line voltage maximum value	5	R				
978-97C	Last month A-phase voltage minimum value	5	R				
97D-981	Last month B-phase voltage minimum value	5	R				
982-986	Last month C-phase voltage minimum value	5	R				
987-98B	Last month AB line voltage minimum value	5	R				
98C-990	Last month BC line voltage minimum value	5	R				

991-995	Last month CA line voltage minimum value	5	R				
A1D-A1E	Last month CH1 A-phase current maximum value	2	R	A	float		
A1F	Last month occurrence time of CH1 A current maximum value	1	R		uint16_t	Year	Month
A20		1	R		uint16_t	Day	Hour
A21		1	R		uint16_t	Minute	Second
A22-A26	Last month CH1 B-phase current maximum value	5	R				
A27-A2B	Last month CH1 C-phase current maximum value	5	R				
A2C-A30	Last month CH1 Zero sequence current maximum value	5	R				
A31-A35	Last month CH1 A-phase active power maximum value	5	R				
A36-A3A	Last month CH1 B-phase active power maximum value	5	R				
A3B-A3F	Last month CH1 C-phase active power maximum value	5	R				
A40-A44	Last month CH1 active power maximum value	5	R				
A45-A49	Last month CH1 A-phase reactive power maximum value	5	R				
A4A-A4E	Last month CH1 B-phase reactive power maximum value	5	R				
A4F-A53	Last month CH1 C-phase reactive power maximum value	5	R				
A54-A58	Last month CH1 reactive power maximum value	5	R				
A59-A5D	Last month CH1 A-phase apparent power maximum value	5	R				
A5E-A62	Last month CH1 B-phase apparent power maximum value	5	R				
A63-A67	Last month CH1 C-phase apparent power maximum value	5	R				
A68-A6C	Last month CH1 apparent power maximum value	5	R				
A6D-A71	Last month CH1 A-phase power factor maximum value	5	R				
A72-A76	Last month CH1 B-phase power factor maximum value	5	R				
A77-A7B	Last month CH1 C-phase power factor maximum value	5	R				
A7C-A80	Last month CH1 power factor maximum value	5	R				
A81-A85	Last month CH1 load rate maximum value	5	R				
AEF-AF0	Last month CH1 A-phase current minimum value	2	R	A	float		
AF1	Last month occurrence time of CH1 A-phase	1	R		uint16_t	Year	Month

AF2	current minimum value	1	R		uint16_t	Day	Hour
AF3		1	R		uint16_t	Minute	Second
AF4-AF8	Last month CH1 B-phase current minimum value	5	R				
AF9-AFD	Last month CH1 C-phase current minimum value	5	R				
AFE-B02	Last month CH1 Zero sequence current minimum	5	R				
B03-B07	Last month CH1 A-phase active power minimum value	5	R				
B08-B0C	Last month CH1 B-phase active power minimum value	5	R				
B0D-B11	Last month CH1 C-phase active power minimum value	5	R				
B12-B16	Last month CH1 active power minimum value	5	R				
B17-B1B	Last month CH1 A-phase reactive power minimum value	5	R				
B1C-B20	Last month CH1 B-phase reactive power minimum value	5	R				
B21-B25	Last month CH1 C-phase reactive power minimum value	5	R				
B26-B2A	Last month CH1 reactive power minimum value	5	R				
B2B-B2F	Last month CH1 A-phase apparent power minimum value	5	R				
B30-B34	Last month CH1 B-phase apparent power minimum value	5	R				
B35-B39	Last month CH1 C-phase apparent power minimum value	5	R				
B3A-B3E	Last month CH1 apparent power minimum value	5	R				
B3F-B43	Last month CH1 A-phase power factor minimum value	5	R				
B44-B48	Last month CH1 B-phase power factor minimum value	5	R				
B49-B4D	Last month CH1 C-phase power factor minimum value	5	R				
B4E-B52	Last month CH1 power factor minimum value	5	R				
B53-B57	Last month CH1 load rate minimum value	5	R				

The extreme value and occurrence time of CH2-CH3 refer to the table above for the extreme value and occurrence time of CH1:

Word Address	Variate	Word Address	Variate
D00-D01	This month CH2 A-phase current maximum value	1000-1001	This month CH3 A-phase current maximum value
D02	This month occurrence time of CH2 A	1002	This month occurrence time of CH3 A

D03	current maximum value	1003	current maximum value
D04		1004	
D05-D09	This month CH2 B-phase current maximum value	1005-1009	This month CH3 B-phase current maximum value
D0A-D0E	This month CH2 C-phase current maximum value	100A-100E	This month CH3 C-phase current maximum value
D0F-D13	This month CH2 Zero sequence current maximum value	100F-1013	This month CH3 Zero sequence current maximum value
D14-D18	This month CH2 A-phase active power maximum value	1014-1018	This month CH3 A-phase active power maximum value
D19-D1D	This month CH2 B-phase active power maximum value	1019-101D	This month CH3 B-phase active power maximum value
D1E-D22	This month CH2 C-phase active power maximum value	101E-1022	This month CH3 C-phase active power maximum value
D23-D27	This month CH2 active power maximum value	1023-1027	This month CH3 active power maximum value
D28-D2C	This month CH2 A-phase reactive power maximum value	1028-102C	This month CH3 A-phase reactive power maximum value
D2D-D31	This month CH2 B-phase reactive power maximum value	102D-1031	This month CH3 B-phase reactive power maximum value
D32-D36	This month CH2 C-phase reactive power maximum value	1032-1036	This month CH3 C-phase reactive power maximum value
D37-D3B	This month CH2 reactive power maximum value	1037-103B	This month CH3 reactive power maximum value
D3C-D40	This month CH2 A-phase apparent power maximum value	103C-1040	This month CH3 A-phase apparent power maximum value
D41-D45	This month CH2 B-phase apparent power maximum value	1041-1045	This month CH3 B-phase apparent power maximum value
D46-D4A	This month CH2 C-phase apparent power maximum value	1046-104A	This month CH3 C-phase apparent power maximum value
D4B-D4F	This month CH2 apparent power maximum value	104B-104F	This month CH3 apparent power maximum value
D50-D54	This month CH2 A-phase power factor maximum value	1050-1054	This month CH3 A-phase power factor maximum value
D55-D59	This month CH2 B-phase power factor maximum value	1055-1059	This month CH3 B-phase power factor maximum value
D5A-D5E	This month CH2 C-phase power factor maximum value	105A-105E	This month CH3 C-phase power factor maximum value
D5F-D63	This month CH2 power factor maximum value	105F-1063	This month CH3 power factor maximum value
D64-D68	This month CH2 load rate maximum value	1064-1068	This month CH3 load rate maximum value
DD2-DD3	This month CH2 A-phase current minimum value	10D2-10D3	This month CH3 A-phase current minimum value
DD4	This month occurrence time of CH2 A current minimum value	10D4	This month occurrence time of CH3 A current minimum value
DD5		10D5	
DD6		10D6	

DD7-DDB	This month CH2 B-phase current minimum value	10D7-10DB	This month CH3 B-phase current minimum value
DDC-DE0	This month CH2 C-phase current minimum value	10DC-10E0	This month CH3 C-phase current minimum value
DE1-DE5	This month CH2 Zero sequence current minimum value	10E1-10E5	This month CH3 Zero sequence current minimum value
DE6-DEA	This month CH2 A-phase active power minimum value	10E6-10EA	This month CH3 A-phase active power minimum value
DEB-E21	This month CH2 B-phase active power minimum value	10EB-113C	This month CH3 B-phase active power minimum value
DF0-E26	This month CH2 C-phase active power minimum value	10F0-113D	This month CH3 C-phase active power minimum value
DF5-E2B	This month CH2 active power minimum value	10F5-113E	This month CH3 active power minimum value
DFA-E30	This month CH2 A-phase reactive power minimum value	10FA-113F	This month CH3 A-phase reactive power minimum value
DFF-E35	This month CH2 B-phase reactive power minimum value	10FF-1144	This month CH3 B-phase reactive power minimum value
E04-E3A	This month CH2 C-phase reactive power minimum value	1104-1149	This month CH3 C-phase reactive power minimum value
E09	This month CH2 reactive power minimum value	1109-114E	This month CH3 reactive power minimum value
EOE	This month CH2 A-phase apparent power minimum value	110E-1153	This month CH3 A-phase apparent power minimum value
E13	This month CH2 B-phase apparent power minimum value	1113-1158	This month CH3 B-phase apparent power minimum value
E18	This month CH2 C-phase apparent power minimum value	1118-115D	This month CH3 C-phase apparent power minimum value
E1D-E21	This month CH2 apparent power minimum value	111D-1121	This month CH3 apparent power minimum value
E22-E26	This month CH2 A-phase power factor minimum value	1122-1126	This month CH3 apparent power minimum value
E27-E2B	This month CH2 B-phase power factor minimum value	1127-112B	This month CH3 A-phase power factor minimum value
E2C-E30	This month CH2 C-phase power factor minimum value	112C-1130	This month CH3 B-phase power factor minimum value
E31-E35	This month CH2 power factor minimum value	1131-1135	This month CH3 C-phase power factor minimum value
E36-E3A	This month CH2 load rate minimum value	1136-113A	This month CH3 load rate minimum value
D69-D6A	Last month CH2 A-phase current maximum value	1069-106A	Last month CH3 A-phase current maximum value
D6B	Last month occurrence time of CH2 A current maximum value	106B	Last month occurrence time of CH3 A current maximum value
D6C		106C	
D6D		106D	
D6E-D72	Last month CH2 B-phase current maximum value	106E-1072	Last month CH3 B-phase current maximum value

D73-D77	Last month CH2 C-phase current maximum value	1073-1077	Last month CH3 C-phase current maximum value
D78-D7C	Last month CH2 Zero sequence current maximum value	1078-107C	Last month CH3 Zero sequence current maximum value
D7D-D81	Last month CH2 A-phase active power maximum value	107D-1081	Last month CH3 A-phase active power maximum value
D82-D86	Last month CH2 B-phase active power maximum value	1082-1086	Last month CH3 B-phase active power maximum value
D87-D8B	Last month CH2 C-phase active power maximum value	1087-108B	Last month CH3 C-phase active power maximum value
D8C-D90	Last month CH2 active power maximum value	108C-1090	Last month CH3 active power maximum value
D91-D95	Last month CH2 A-phase reactive power maximum value	1091-1095	Last month CH3 A-phase reactive power maximum value
D96-D9A	Last month CH2 B-phase reactive power maximum value	1096-109A	Last month CH3 B-phase reactive power maximum value
D9B-D9F	Last month CH2 C-phase reactive power maximum value	109B-109F	Last month CH3 C-phase reactive power maximum value
DA0-DA4	Last month CH2 reactive power maximum value	10A0-10A4	Last month CH3 reactive power maximum value
DA5-DA9	Last month CH2 A-phase apparent power maximum value	10A5-10A9	Last month CH3 A-phase apparent power maximum value
DAA-DAE	Last month CH2 B-phase apparent power maximum value	10AA-10AE	Last month CH3 B-phase apparent power maximum value
DAF-DB3	Last month CH2 C-phase apparent power maximum value	10AF-10B3	Last month CH3 C-phase apparent power maximum value
DB4-DB8	Last month CH2 apparent power maximum value	10B4-10B8	Last month CH3 apparent power maximum value
DB9-DBD	Last month CH2 A-phase power factor maximum value	10B9-10BD	Last month CH3 A-phase power factor maximum value
DBE-DC2	Last month CH2 B-phase power factor maximum value	10BE-10C2	Last month CH3 B-phase power factor maximum value
DC3-DC7	Last month CH2 C-phase power factor maximum value	10C3-10C7	Last month CH3 C-phase power factor maximum value
DC8-DCC	Last month CH2 power factor maximum value	10C8-10CC	Last month CH3 power factor maximum value
DCD-DD1	Last month CH2 load rate maximum value	10CD-10D1	Last month CH3 load rate maximum value
E3B-E3C	Last month CH2 A-phase current minimum value	113B-113C	Last month CH3 A-phase current minimum value
E3D	Last month occurrence time of CH2 A current minimum value	113D	Last month occurrence time of CH3 A current minimum value
E3E		113E	
E3F		113F	
E40-E44	Last month CH2 B-phase current minimum value	1140-1144	Last month CH3 B-phase current minimum value
E45-E49	Last month CH2 C-phase current minimum value	1145-1149	Last month CH3 C-phase current minimum value

E4A-E4E	Last month CH2 Zero sequence current minimum value	114A-114E	Last month CH3 Zero sequence current minimum value
E4F-E53	Last month CH2 A-phase active power minimum value	114F-1153	Last month CH3 A-phase active power minimum value
E54-E58	Last month CH2 B-phase active power minimum value	1154-1158	Last month CH3 B-phase active power minimum value
E59-E5D	Last month CH2 C-phase active power minimum value	1159-115D	Last month CH3 C-phase active power minimum value
E5E-E62	Last month CH2 active power minimum value	115E-1162	Last month CH3 active power minimum value
E63-E67	Last month CH2 A-phase reactive power minimum value	1163-1167	Last month CH3 A-phase reactive power minimum value
E68-E6C	Last month CH2 B-phase reactive power minimum value	1168-116C	Last month CH3 B-phase reactive power minimum value
E6D-E71	Last month CH2 C-phase reactive power minimum value	116D-1171	Last month CH3 C-phase reactive power minimum value
E72-E76	Last month CH2 reactive power minimum value	1172-1176	Last month CH3 reactive power minimum value
E77-E7B	Last month CH2 A-phase apparent power minimum value	1177-117B	Last month CH3 A-phase apparent power minimum value
E7C-E80	Last month CH2 B-phase apparent power minimum value	117C-1180	Last month CH3 B-phase apparent power minimum value
E81-E85	Last month CH2 C-phase apparent power minimum value	1181-1185	Last month CH3 C-phase apparent power minimum value
E86-E8A	Last month CH2 apparent power minimum value	1186-118A	Last month CH3 apparent power minimum value
E8B-E8F	Last month CH2 A-phase power factor minimum value	118B-118F	Last month CH3 A-phase power factor minimum value
E90-E94	Last month CH2 B-phase power factor minimum value	1190-1194	Last month CH3 B-phase power factor minimum value
E95-E99	Last month CH2 C-phase power factor minimum value	1195-1199	Last month CH3 C-phase power factor minimum value
E9A-E9E	Last month CH2 power factor minimum value	119A-119E	Last month CH3 power factor minimum value
E9F-EA3	Last month CH2 load rate minimum value	119F-11A3	Last month CH3 load rate minimum value
1300-1301	This month CH4 A-phase current maximum value	13D2-13D3	This month CH4 A-phase current minimum value
1302	This month occurrence time of CH4 A current maximum value	13D4	This month occurrence time of CH4 A current minimum value
1303		13D5	
1304		13D6	
1305-1309	This month CH4 B-phase current maximum value	13D7-13DB	This month CH4 B-phase current minimum value
130A-130E	This month CH4 C-phase current maximum value	13DC-13E0	This month CH4 C-phase current minimum value
130F-1313	This month CH4 Zero sequence current maximum value	13E1-13E5	This month CH4 Zero sequence current minimum value

1314-1318	This month CH4 A-phase active power maximum value	13E6-13EA	This month CH4 A-phase active power minimum value
1319-131D	This month CH4 B-phase active power maximum value	13EB-1462	This month CH4 B-phase active power minimum value
131E-1322	This month CH4 C-phase active power maximum value	13F0-1467	This month CH4 C-phase active power minimum value
1323-1327	This month CH4 active power maximum value	13F5-146C	This month CH4 active power minimum value
1328-132C	This month CH4 A-phase reactive power maximum value	13FA-1471	This month CH4 A-phase reactive power minimum value
132D-1331	This month CH4 B-phase reactive power maximum value	13FF-1476	This month CH4 B-phase reactive power minimum value
1332-1336	This month CH4 C-phase reactive power maximum value	1404-147B	This month CH4 C-phase reactive power maximum value
1337-133B	This month CH4 reactive power maximum value	1409-1480	This month CH4 reactive power minimum value
133C-1340	This month CH4 A-phase apparent power maximum value	140E-1485	This month CH4 A-phase apparent power minimum value
1341-1345	This month CH4 B-phase apparent power maximum value	1413-148A	This month CH4 B-phase apparent power minimum value
1346-134A	This month CH4 C-phase apparent power maximum value	1418-148F	This month CH4 C-phase apparent power minimum value
134B-134F	This month CH4 apparent power maximum value	141D-1421	This month CH4 apparent power minimum value
1350-1354	This month CH4 A-phase power factor maximum value	1422-1426	This month CH4 A-phase power factor minimum value
1355-1359	This month CH4 B-phase power factor maximum value	1427-142B	This month CH4 B-phase power factor minimum value
135A-135E	This month CH4 C-phase power factor maximum value	142C-1430	This month CH4 C-phase power factor minimum value
135F-1363	This month CH4 power factor maximum value	1431-1435	This month CH4 power factor minimum value
1364-1368	This month CH4 load rate maximum value	1436-143A	This month CH4 load rate minimum value
1369-136A	Last month CH4 A-phase current maximum value	143B-143C	Last month CH4 A-phase current minimum value
136B	Last month occurrence time of CH4 A current maximum value	143D	Last month occurrence time of CH4 A current minimum value
136C		143E	
136D		143F	
136E-1372	Last month CH4 B-phase current maximum value	1440-1444	Last month CH4 B-phase current minimum value
1373-1377	Last month CH4 C-phase current maximum value	1445-1449	Last month CH4 C-phase current minimum value
1378-137C	Last month CH4 Zero sequence current maximum value	144A-144E	Last month CH4 Zero sequence current minimum value
137D-1381	Last month CH4 A-phase active power maximum value	144F-1453	Last month CH4 A-phase active power minimum value

1382-1386	Last month CH4 B-phase active power maximum value	1454-1458	Last month CH4 B-phase active power minimum value
1387-138B	Last month CH4 C-phase active power maximum value	1459-145D	Last month CH4 C-phase active power minimum value
138C-1390	Last month CH4 active power maximum value	145E-1462	Last month CH4 active power minimum value
1391-1395	Last month CH4 A-phase reactive power maximum value	1463-1467	Last month CH4 A-phase reactive power minimum value
1396-139A	Last month CH4 B-phase reactive power maximum value	1468-146C	Last month CH4 B-phase reactive power minimum value
139B-139F	Last month CH4 C-phase reactive power maximum value	146D-1471	Last month CH4 C-phase reactive power minimum value
13A0-13A4	Last month CH4 reactive power maximum value	1472-1476	Last month CH4 reactive power minimum value
13A5-13A9	Last month CH4 A-phase apparent power maximum value	1477-147B	Last month CH4 A-phase apparent power minimum value
13AA-13AE	Last month CH4 B-phase apparent power maximum value	147C-1480	Last month CH4 B-phase apparent power minimum value
13AF-13B3	Last month CH4 C-phase apparent power maximum value	1481-1485	Last month CH4 C-phase apparent power minimum value
13B4-13B8	Last month CH4 apparent power maximum value	1486-148A	Last month CH4 apparent power minimum value
13B9-13BD	Last month CH4 A-phase power factor maximum value	148B-148F	Last month CH4 A-phase power factor minimum value
13BE-13C2	Last month CH4 B-phase power factor maximum value	1490-1494	Last month CH4 B-phase power factor minimum value
13C3-13C7	Last month CH4 C-phase power factor maximum value	1495-1499	Last month CH4 C-phase power factor minimum value
13C8-13CC	Last month CH4 power factor maximum value	149A-149E	Last month CH4 power factor minimum value
13CD-13D1	Last month CH4 load rate maximum value	149F-14A3	Last month CH4 load rate minimum value

## 6.2 Energy freeze address table

Device Address	Function Code	Start Address		Read Length		Check Digit	
		20	00	00	44	crc1	crc2
adr	03	20	00	00	44	crc1	crc2
<b>Note: The starting address is different and the read freezing date is different; Read length cannot be changed.</b>							
Send: adr 03 20 00 00 00 44 crc1 crc2							
Receive: adr 03 88 xx xx xx xx xx xx xx xx xx xx xx xx xx....crc1 crc2							

The return data address is as follows:

Byte[0]	adr		Byte[67-70]	Freeze CH2 active flat power	float
Byte[1]	0x03		Byte[71-74]	Freeze CH2 active valley power	float
Byte[2]	0x88		Byte[75-78]	Freeze CH3 positive active power	float

Byte[3-4]	Year/Month	uint16_t	Byte[79-82]	Freeze CH3 negative active power	float
Byte[5-6]	Day /Hour	uint16_t	Byte[83-86]	Freeze CH3 positive reactive power	float
Byte[7-8]	Minute/Second	uint16_t	Byte[87-90]	Freeze CH3 negative reactive power	float
Byte[9-10]	Reserved	uint16_t	Byte[91-94]	Freeze CH3 active sharp power	float
Byte[11-14]	Freeze CH1 positive active power	float	Byte[95-98]	Freeze CH3 active peak power	float
Byte[15-18]	Freeze CH1 negative active power	float	Byte[99-102]	Freeze CH3 active flat power	float
Byte[19-22]	Freeze CH1 positive reactive power	float	Byte[103-106]	Freeze CH3 active valley power	float
Byte[23-26]	Freeze CH1 negative reactive power	float	Byte[107-110]	Freeze CH4 positive active power	float
Byte[27-30]	Freeze CH1 active sharp power	float	Byte[111-114]	Freeze CH4 negative active power	float
Byte[31-34]	Freeze CH1 active peak power	float	Byte[115-118]	Freeze CH4 positive reactive power	float
Byte[35-38]	Freeze CH1 active flat power	float	Byte[119-122]	Freeze CH4 negative reactive power	float
Byte[39-42]	Freeze CH1 active valley power	float	Byte[123-126]	Freeze CH4 active sharp power	float
Byte[43-46]	Freeze CH2 positive active power	float	Byte[127-130]	Freeze CH4 active peak power	float
Byte[47-50]	Freeze CH2 negative active power	float	Byte[131-134]	Freeze CH4 active flat power	float
Byte[51-54]	Freeze CH2 positive reactive power	float	Byte[135-138]	Freeze CH4 active valley power	float
Byte[55-58]	Freeze CH2 negative reactive power	float	Byte[139]	crc1	uint8_t
Byte[59-62]	Freeze CH2 active sharp power	float	Byte[140]	crc2	uint8_t
Byte[63-66]	Freeze CH2 active peak power	float			

The specific address is as follows:

Start Address	Freeze Position	Start Address	Freeze Position	Start Address	Freeze Position	Start Address	Freeze Position
2000	Last 1 day	2007	Last 8 days	200F	Last 16 days	2017	Last 24 days
2001	Last 2 days	2008	Last 9 days	2010	Last 17 days	2018	Last 25 days
2002	Last 3 days	2009	Last 10 days	2011	Last 18 days	2019	Last 26 days
2003	Last 4 days	200A	Last 11 days	2012	Last 19 days	201A	Last 27 days
2004	Last 5 days	200B	Last 12 days	2013	Last 20 days	201B	Last 28 days
2005	Last 6 days	200C	Last 13 days	2014	Last 21 days	201C	Last 29 days
2006	Last 7 days	200D	Last 14 days	2015	Last 22 days	201D	Last 30 days

2007	Last 8 days	200E	Last 15 days	2016	Last 23 days	201E	Last 31 days
------	-------------	------	--------------	------	--------------	------	--------------

### 6.3 Data record address table

Device Address	Function Code	Start Address		Data Length		Check Digit	
adr	03	21	00	00	08	crc1	crc2

Note: Different starting addresses **correspond to different records**; **Read length cannot be changed.**

Send: 01 03 21 00 00 08 crc1 crc2

Receive: 01 03 10 FF 00 80 81 00 00 13 08 1D 10 12 22 00 00 00 00 25 92

The return data address is as follows:

Hi	Lo	Hi	Lo	Hi	Lo	Hi	Lo	Hi	Lo	Hi	Lo	Hi	Lo	Hi	Lo	
0x00:DO0	Alarm Type	bit7	Switch number			Year	Month	Day	Hour	Minute	Second	Alarm value				
0x01:DO1		0: DO														0x00+num:
0xFF:		1: DI														branch part
event logging		bit0														0x80+num:
		1: close	main part													
		0: open														

The specific event logging address is as follows:

0x2100	Article 1	0x2128	Article 41	0x2150	Article 81	0x2178	Article 121	0x21A0	Article 161
0x2101	Article 2	0x2129	Article 42	0x2151	Article 82	0x2179	Article 122	0x21A1	Article 162
0x2102	Article 3	0x212A	Article 43	0x2152	Article 83	0x217A	Article 123	0x21A2	Article 163
0x2103	Article 4	0x212B	Article 44	0x2153	Article 84	0x217B	Article 124	0x21A3	Article 164
0x2104	Article 5	0x212C	Article 45	0x2154	Article 85	0x217C	Article 125	0x21A4	Article 165
0x2105	Article 6	0x212D	Article 46	0x2155	Article 86	0x217D	Article 126	0x21A5	Article 166
0x2106	Article 7	0x212E	Article 47	0x2156	Article 87	0x217E	Article 127	0x21A6	Article 167
0x2107	Article 8	0x212F	Article 48	0x2157	Article 88	0x217F	Article 128	0x21A7	Article 168
0x2108	Article 9	0x2130	Article 49	0x2158	Article 89	0x2180	Article 129	0x21A8	Article 169
0x2109	Article 10	0x2131	Article 50	0x2159	Article 90	0x2181	Article 130	0x21A9	Article 170
0x210A	Article 11	0x2132	Article 51	0x215A	Article 91	0x2182	Article 131	0x21AA	Article 171
0x210B	Article 12	0x2133	Article 52	0x215B	Article 92	0x2183	Article 132	0x21AB	Article 172
0x210C	Article 13	0x2134	Article 53	0x215C	Article 93	0x2184	Article 133	0x21AC	Article 173
0x210D	Article 14	0x2135	Article 54	0x215D	Article 94	0x2185	Article 134	0x21AD	Article 174
0x210E	Article 15	0x2136	Article 55	0x215E	Article 95	0x2186	Article 135	0x21AE	Article 175
0x210F	Article 16	0x2137	Article 56	0x215F	Article 96	0x2187	Article 136	0x21AF	Article 176
0x2110	Article 17	0x2138	Article 57	0x2160	Article 97	0x2188	Article 137	0x21B0	Article 177
0x2111	Article 18	0x2139	Article 58	0x2161	Article 98	0x2189	Article 138	0x21B1	Article 178
0x2112	Article 19	0x213A	Article 59	0x2162	Article 99	0x218A	Article 139	0x21B2	Article 179
0x2113	Article 20	0x213B	Article 60	0x2163	Article 100	0x218B	Article 140	0x21B3	Article 180
0x2114	Article 21	0x213C	Article 61	0x2164	Article 101	0x218C	Article 141	0x21B4	Article 181
0x2115	Article 22	0x213D	Article 62	0x2165	Article 102	0x218D	Article 142	0x21B5	Article 182
0x2116	Article 23	0x213E	Article 63	0x2166	Article 103	0x218E	Article 143	0x21B6	Article 183
0x2117	Article 24	0x213F	Article 64	0x2167	Article 104	0x218F	Article 144	0x21B7	Article 184
0x2118	Article 25	0x2140	Article 65	0x2168	Article 105	0x2190	Article 145	0x21B8	Article 185
0x2119	Article 26	0x2141	Article 66	0x2169	Article 106	0x2191	Article 146	0x21B9	Article 186
0x211A	Article 27	0x2142	Article 67	0x216A	Article 107	0x2192	Article 147	0x21BA	Article 187
0x211B	Article 28	0x2143	Article 68	0x216B	Article 108	0x2193	Article 148	0x21BB	Article 188
0x211C	Article 29	0x2144	Article 69	0x216C	Article 109	0x2194	Article 149	0x21BC	Article 189

0x211D	Article 30	0x2145	Article 70	0x216D	Article 110	0x2195	Article 150	0x21BD	Article 190
0x211E	Article 31	0x2146	Article 71	0x216E	Article 111	0x2196	Article 151	0x21BE	Article 191
0x211F	Article 32	0x2147	Article 72	0x216F	Article 112	0x2197	Article 152	0x21BF	Article 192
0x2120	Article 33	0x2148	Article 73	0x2170	Article 113	0x2198	Article 153	0x21C0	Article 193
0x2121	Article 34	0x2149	Article 74	0x2171	Article 114	0x2199	Article 154	0x21C1	Article 194
0x2122	Article 35	0x214A	Article 75	0x2172	Article 115	0x219A	Article 155	0x21C2	Article 195
0x2123	Article 36	0x214B	Article 76	0x2173	Article 116	0x219B	Article 156	0x21C3	Article 196
0x2124	Article 37	0x214C	Article 77	0x2174	Article 117	0x219C	Article 157	0x21C4	Article 197
0x2125	Article 38	0x214D	Article 78	0x2175	Article 118	0x219D	Article 158	0x21C5	Article 198
0x2126	Article 39	0x214E	Article 79	0x2176	Article 119	0x219E	Article 159	0x21C6	Article 199
0x2127	Article 40	0x214F	Article 80	0x2177	Article 120	0x219F	Article 160	0x21C7	Article 200

## 7 Common Troubleshooting

### Analysis and troubleshooting of common faults

Fault Content	Analysis	Remark
No display when power on	Check whether the power supply voltage is within the operating voltage range.	
Incorrect readings of voltage, current, energy, etc.	Check whether the voltage-to-current ratio setting is correct. Check whether the wiring mode setting is consistent with the actual. Check whether the voltage transformer and current transformer are in good condition.	
Incorrect power or power factor	Check whether the wiring mode setting is consistent with the actual. Check whether the voltage and current phase sequence is correct. Check whether the wiring is correct.	
Abnormal communication	Check whether the address, baud rate, check digit, etc. in the communication settings are consistent with the host computer. Check whether the RS485 converter is normal. The communication terminal should be connected in parallel with a resistance of more than 120 ohms. Check whether the wiring is correct.	

Headquarter: Acrel Co., Ltd.

Address: 253 Yulv Road, Jiading District, Shanghai

Telephone: 0086-21-69158338 0086-21-69156052 0086-21-59156392 0086-21-69156971

Fax: 0086-21-69158303

Website: [www.acrel-electric.com](http://www.acrel-electric.com)

Email: [ACREL001@vip.163.com](mailto:ACREL001@vip.163.com)

ZIP code: 201801

Manufacturing base: Jiangsu Acrel Electrical Manufacturing Co., LTD.

Address: No.5 Dongmeng Road, Nanzha Street, Jiangyin City

Telephone: 0086-510-86179966

Fax: 0086-510-86179975

Website: [www.jsacrel.com](http://www.jsacrel.com)

Email: [sales@email.acrel.cn](mailto:sales@email.acrel.cn)

ZIP code: 214405