

ATP 系列无线测温集中采集触摸屏
ATP series wireless temperature measurement
centralized collection touch screen

安装使用说明书 V1.2
Installation Instruction V1.2

申 明

DECLARATION

版权所有，未经本公司之书面许可，此手册中任何段落，章节内容均不得被摘抄、拷贝或以任何形式复制、传播，否则一切后果由违者自负。

本公司保留一切法律权利。

All rights reserved. No part of this publication may be reproduced, stored in a retrieval system, or transmitted in any form by any means, electronic, mechanical photocopying, recording, or otherwise without prior permission of our company. The violator will bear the dependent legal responsibility.

We reserve all the rights.

本公司保留对本手册所描述之产品规格进行修改的权利，恕不另行通知。

订货前，请垂询当地代理商以获悉本产品的最新规格。

We reserve all the rights to revise product specification without notice. Please consult local agent to get the latest information of our products specification

1 安装使用指南

1 Installation Guide

1.1 产品概述

1.1 Product Introduction

ATP 系列无线测温集中采集触摸屏适用于高压开关柜触点及接点、刀闸开关、高压电缆中间头、干式变压器、低压大电流等设备的温度监测。该触摸屏可以与无线测温收发器搭配使用，实现 240 个无线测温传感器数据采集，匹配的传感器包括 ATE100M、ATE100、ATE200、ATE100P、ATE200P、ATE400 等。无线温度传感器与收发器交换通过无线信号传送，不会影响系统的绝缘性能，使用更安全。装置具有隔离彻底、安装方便、抗干扰能力强、工作可靠等特点，解决了高电压状态下的接触式温度监测的安全问题。

ATP series wireless temperature measurement centralized collection touch is applicable to temperature monitoring of contacts points and connection points of High-Voltage Switchgear, knife switch and middle head of high voltage cable、dry-type transformer、Low voltage and high current and other equipment.The touch screen can be used with wireless temperature measurement transceiver to realize data acquisition of 240 wireless temperature measurement sensors, including ATE 100M, ATE100, ATE200, ATE100P, ATE200P, ATE400, etc.Wireless temperature sensor and transceiver exchange through wireless signal transmission, will not affect the insulation performance of the system and use safer.The device has the characteristics of complete isolation, convenient installation, strong anti-interference ability and reliable operation, which solves the safety problem of contact temperature monitoring under high voltage state.

1.2 主要技术指标

1.2 Technical Features

表 1 ATP 系列无线测温集中采集触摸屏技术指标

Table 1 technical indicators of ATP series wireless temperature measurement centralized collection touch

项目 Items	指标 Features
触摸屏型号 Type of touch screen	ATP007,ATP010
工作电源 Power source	DC 24V (±10%) , 15W

测温点数 Points of temperature		240 点 240 points
测温范围 Range of temperature		-50℃~125℃
温度精度 Precision		±1℃
传感器电池寿命 Battery life		≥5 年 ≥5 years
通讯 communication	接口 Interface	RS485/以太网 RS485/Ethernet
	协议 Protocol	Modbus-RTU/ Modbus-TCP
环境要求	工作温度 Temperature	0℃~50℃
	相对湿度 Humidity	≤95%
	海拔高度 Altitude	≤3000m
有源无线测温传 感器 Active wired temperature sensor	有源传感器型号 Active sensor type	ATE100M、ATE100、ATE200
	无线频率 Wireless frequency	470MHz
	通讯距离 Communication distance	空旷 150m 150m in open area
	采样频率 Sampling frequency	25s
	发射频率 Transmission frequency	25s-5min
	工作电源 Power source	电池 battery
	安装方式 Installation	磁吸式/螺栓式/表带式 Magnetic / bolted /Belt
	测温范围 Range of temperature	-50℃~+125℃
	精度 Precision	±1℃

	应用范围 Application	高低压柜内电气接头 Joints in high or low voltage switchgears
	电池寿命 Battery life	≥5 年 ≥5 years
无源无线测温传感器 Passive wireless temperature sensor	无源传感器型号 Passive sensor type	ATE400
	无线频率 Wireless frequency	470MHz
	通讯距离 Communication distance	空旷 150m 150m in open area
	采样频率 Sampling frequency	15s
	发射频率 Transmitting frequency	15s
	工作电源 Power source	感应取电, 启动电流>5A CT-powered, starting current≥5A
	安装方式 Installation	合金片固定 alloy chip fixing
	传感器探头 Sensor probe	合金底座 Alloy base
	测温范围 Range of temperature	50℃~125℃
	精度 Precision	±1℃
	应用范围 Application	高低压柜内电气接头 Joints in high or low voltage switchgears
户外无线温度传感器 Outdoor wireless temperature sensor	有源传感器型号 Active sensor type	ATE100P、ATE200P
	无线频率 Wireless frequency	470MHz
	通讯距离 Communication distance	空旷 150m 150m in open area
	采样频率 Sampling frequency	25s
	发射频率 Transmitting frequency	25s-5min

	工作电源 Power source	电池 Battery
	安装方式 Installation	螺栓式/表带式 bolted /Belt
	测温范围 Range of temperature	-50℃~+150℃
	精度 Precision	±0.5℃
	应用范围 Application	电气接头 Voltage switchgears
	电池寿命 Battery life	≥5年 ≥5 years
	防护等级 Protection level	IP68

1.3 产品拓扑图

1.3 Product topology

1.3.1 搭配 ATC450-C 方案

1.3.1 With ATC450-C scheme

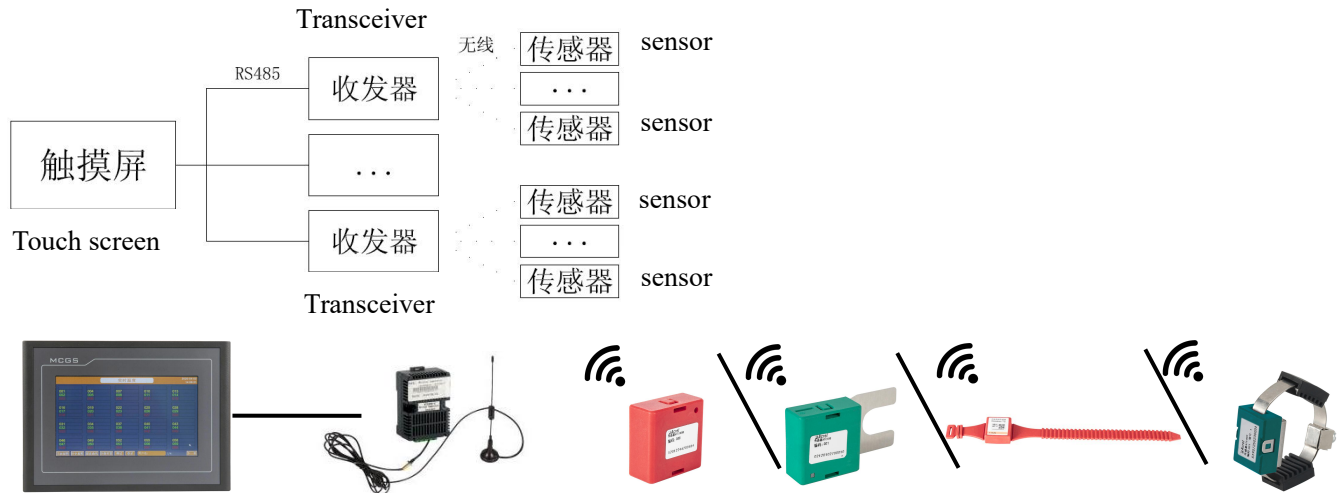

名称 Name	型号 Type	数量 Number
触摸屏 Touch screen	ATP007/ATP010	1
无线温度收发器 Wireless temperature transceiver	ATC450-C	4
无线测温传感器 Wireless temperature transceiver	ATE100M/ATE100/ATE200/ATE100P/ATE200P/ATE400	240

1.3.2 搭配 ATC600 方案

1.3.2 With ATC600 scheme

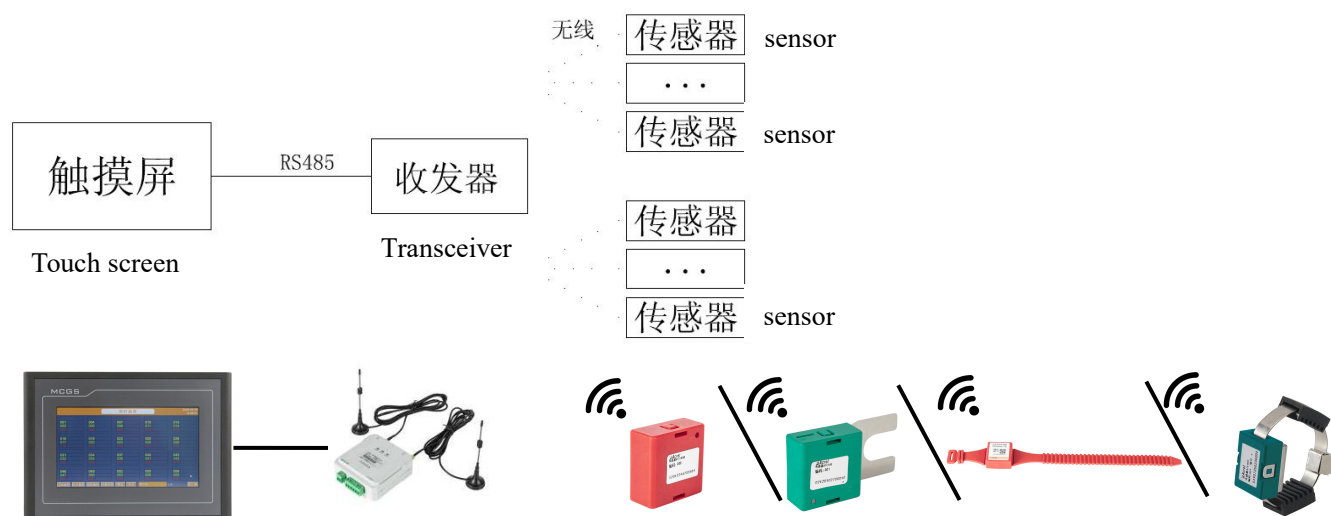

名称 Name	型号 Type	数量 Number
触摸屏 Touch screen	ATP007/ATP010	1
无线温度收发器 Wireless temperature transceiver	ATC600-C	1
中继收发器 Relay transceiver	ATC600-Z	N
无线测温传感器 Wireless temperature transceiver	ATE100M/ATE100/ATE200/ATE100P/ATE200P/ATE400	240

1.4 产品安装

1.4 Product Installation

1.4.1 触摸屏安装方法

1.4.1 Installation method of touch screen

ATP 系列无线测温系统使用的触摸屏采用面板嵌入式安装，产品尺寸及安装开孔尺寸如图 1.1、图 1.2 所示。安装方法见图 1.3。

Touch screen ATP series wireless temperature measurement system uses panel embedded installation. The product size and installation hole size are shown in Figure 1.1 and Figure 1.2. The installation method is shown in Figure 1.3



图 1.1 ATP007 触摸屏开孔尺寸 (单位 mm)

Figure 1.1 hole size of atp007 touch screen (unit: mm)

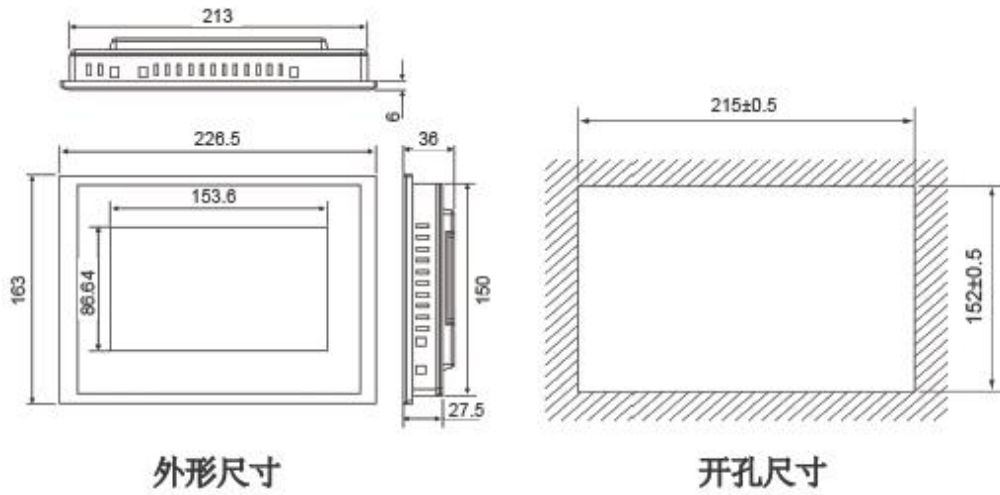

图 1.2 ATP010 触摸屏开孔尺寸 (单位 mm)

Figure 1.2 hole size of atp010 touch screen (unit: mm)

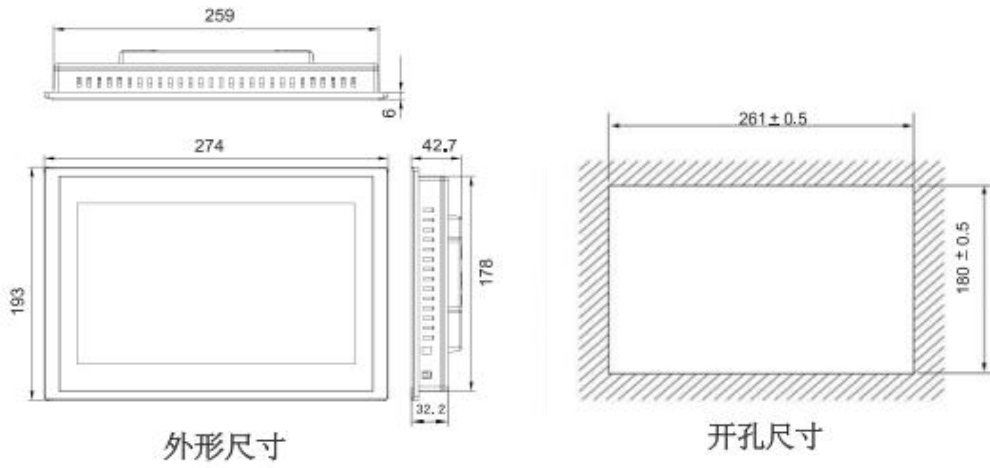

图 1.3 触摸屏安装方法

Figure 1.3 installation method of touch screen

1.4.2 无线温度收发器的安装

1.4.2 Installation of wireless temperature transceiver

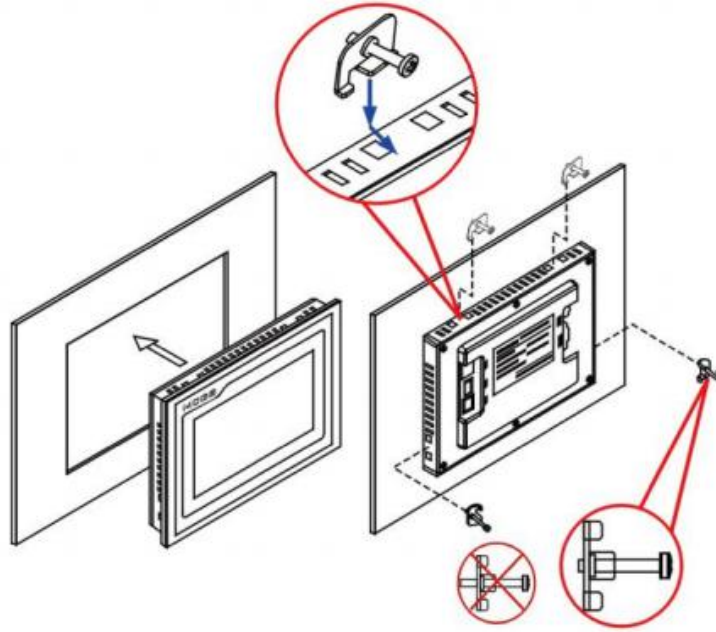
无线测温收发器，可以采用导轨（DIN35mm）安装方式，也可以使用螺栓固定方式，如图 1.4、图 1.5 所示。

The wireless temperature measurement transceiver can be installed by guide rail (din35mm) or bolt fixing method, as shown in Figure 1.4 and Figure 1.5.



图 1.4 ATC450-C 无线温度收发器外形及安装示例

Figure 1.4 appearance and installation example of wireless temperature transceiver

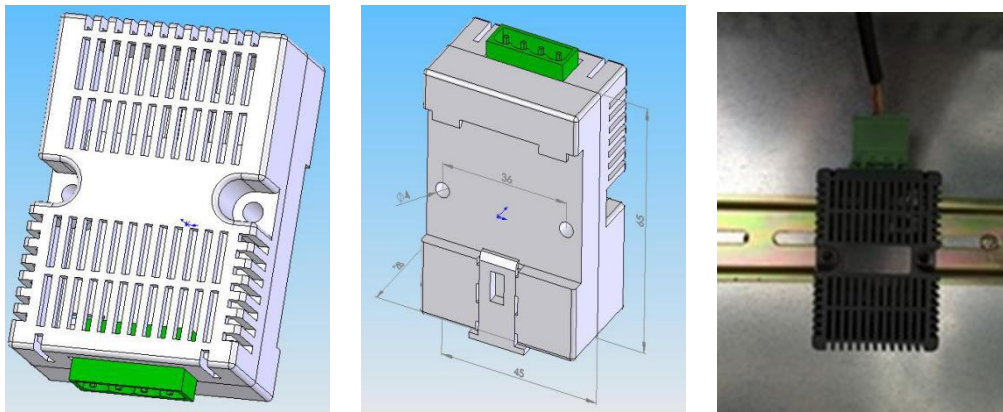

图 1.5 ATC600 无线温度收发器外形及安装示例

Figure 1.5 appearance and installation example of wireless temperature transceiver

1.4.3 无线温度传感器的安装

1.4.3 Installation of wireless temperature sensor

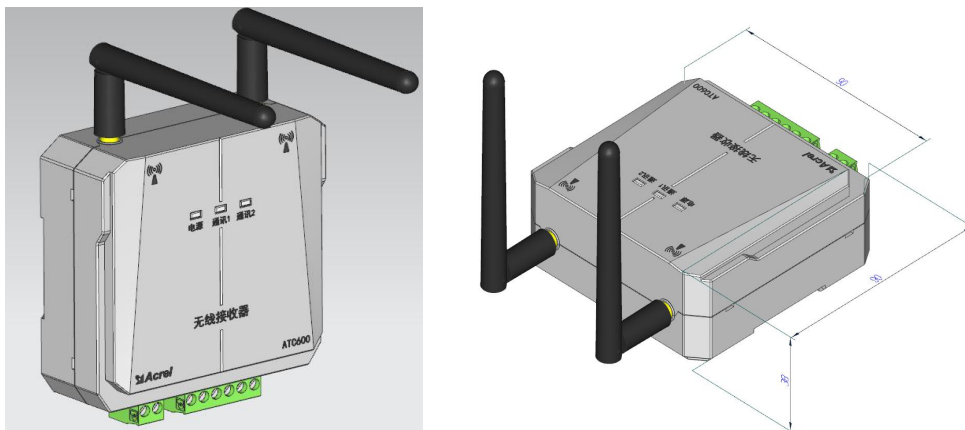
无线温度传感器共有多种型号，分别对应磁吸固定、螺栓固定、表带固定、合金片固定等安装方式。

Wireless temperature sensor has a variety of models, part are magnetic absorption fixation, bolt fixation, strap fixation, alloy plate fixation and other installation method.



图 1.6 表带式无线温度传感器 ATE200/200P

Figure 1.6 Belt wireless temperature sensor ATE200/ATE200P

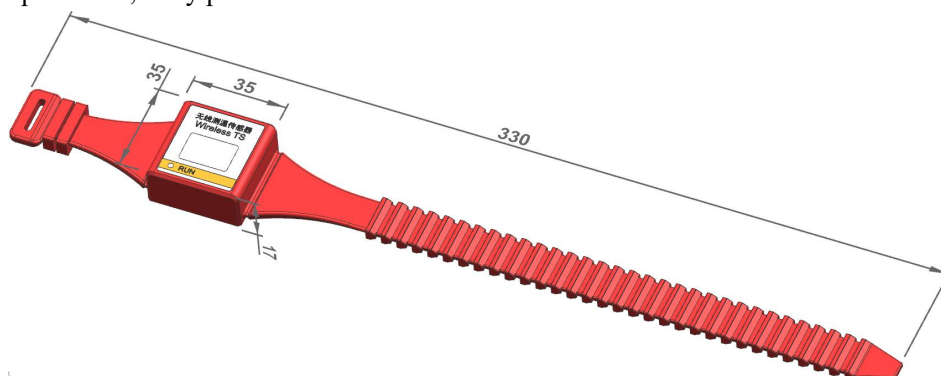

图 1.7 磁吸式无线温度传感器 ATE100M

Figure 1.7 Magnetic wireless temperature sensor ATE100M

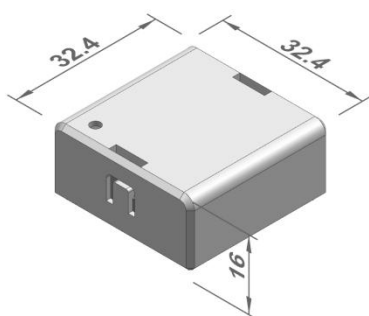

图 1.8 螺栓式无线温度传感器 ATE100/100P

Figure 1.8 Bolted wireless temperature sensor ATE100/100P

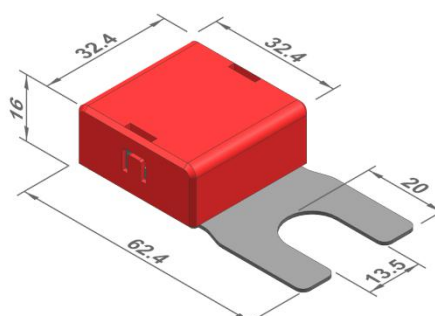

图 1.9 无源无线温度传感器 ATE400

Figure 1.9 passive wireless temperature sensor ATE400

1.5 触摸屏背部端子图

1.5 back terminal diagram of touch screen

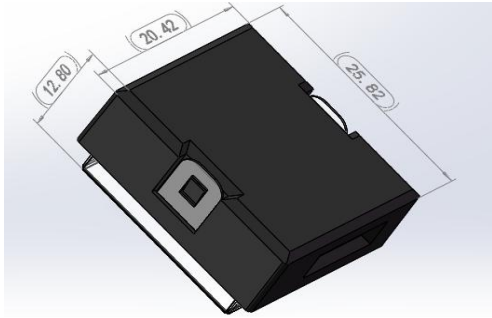

图 1.10 触摸屏背部端子

Figure 1.10 back terminal of touch screen

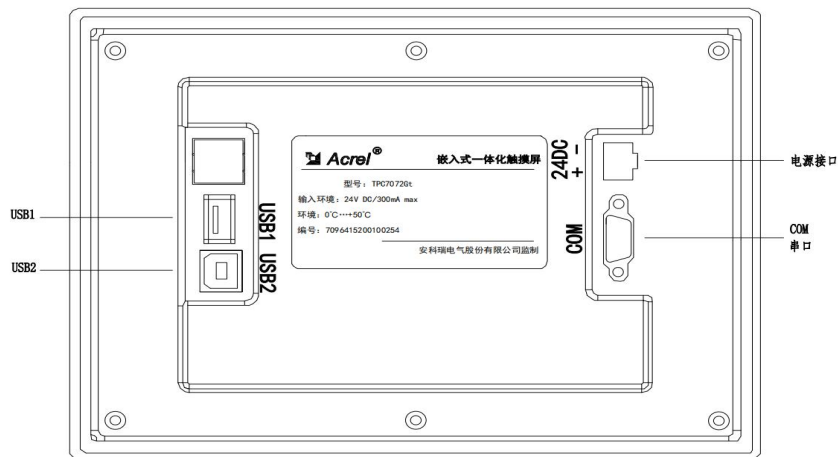
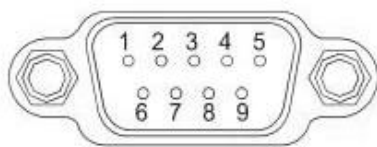

串口引脚定义

接口	PIN	引脚定义
COM1	2	RS232 RXD
	3	RS232 TXD
	5	GND
COM2	7	RS485 +
	8	RS485 -
COM3	4	RS485 +
	9	RS485 -

图 1.11 串口引脚定义

Figure 1.11 serial port pin definition

触摸屏出厂配置有一根转接线(INC0702Z), 其中红、蓝 (7-8) 是下行, 和模块的 485 相连, 绿、白 (4-9) 上行, 转动环用。

The touch screen factory is equipped with an adapter line (inc0702z), in which the red and blue (7-8) are downlink, connected with the 485 of the module, the green and white (4-9) are uplink, and used for the rotary ring.

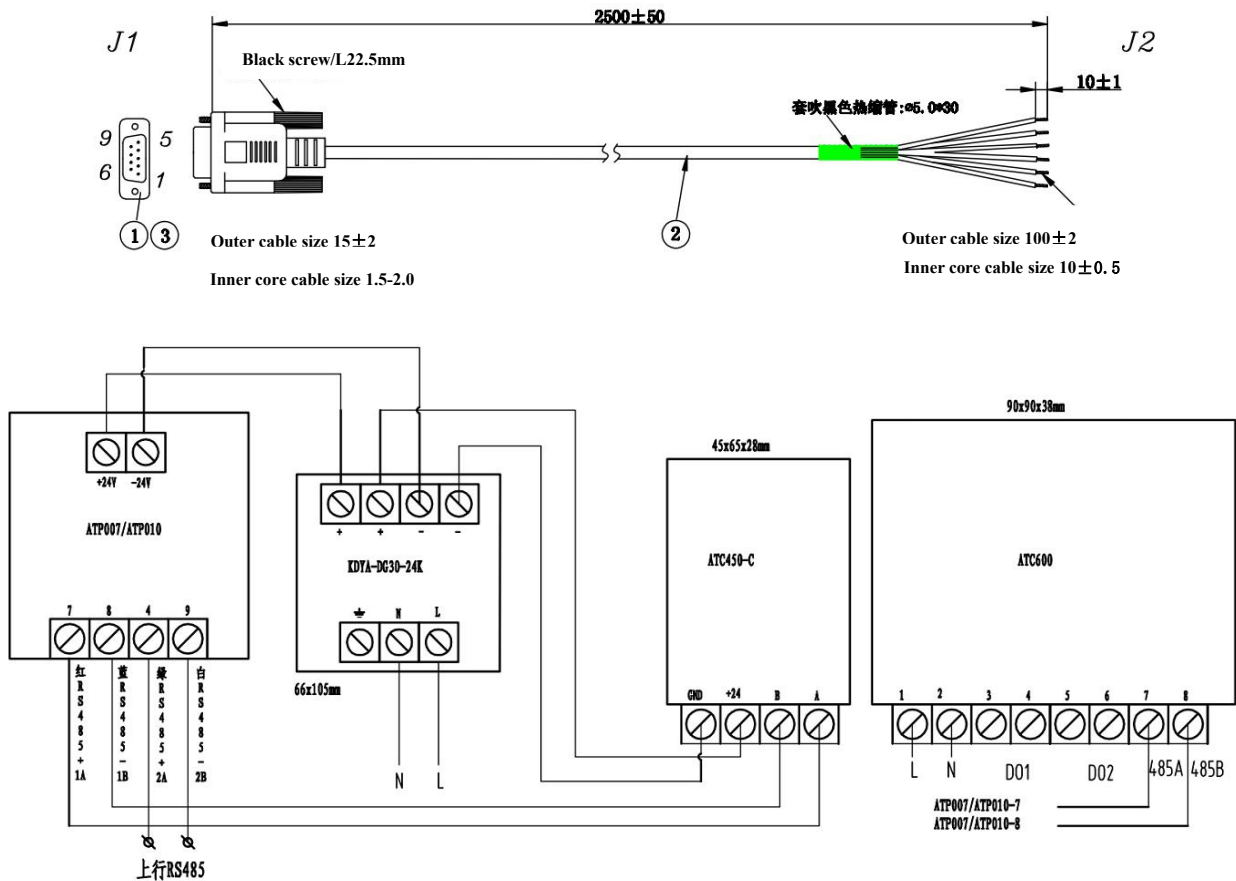

2 产品操作指南

2 Product operation guide

安装好触摸显示屏及无线温度收发器，并连接好两者之间的通讯线缆，然后通过电源转换器给两者接通 DC 24V 的工作电源。打开测温点处的无线温度传感器的开关，触摸屏即可接收并显示各温度传感器节点的温度。

Install the touch screen and wireless temperature transceiver, and connect the communication cable between them, and then connect them with DC 24V working power through the power converter. Turn on the switch of the wireless temperature sensor at the temperature measuring point, and the touch screen can receive and display the temperature of each temperature sensor.

2.1 温度显示

2.1 temperature display

触摸屏上电进入工作状态后，默认即为“实时温度”界面，再此界面可观察到各节点采集的温度值。

After the touch screen is powered on and enters the working state, the default is the "real time temperature" interface, and then the temperature value collected by each point can be monitored on this interface.





图 2.1 实时温度界面

Figure 2.1 real time temperature interface

2.2 定值设置

2.2 setting value

用户“登录”（“用户”默认登录密码为 0008，可通过登录界面修改密码）后，可以通过“参数设置”菜单设置无线温度传感器组的高温告警值和名称，当测得温度值超出设定值时，触摸屏显示告警并且蜂鸣器鸣叫；同时可以设置中英文语言切换。**设置好参数之后，一定要点击“保存设置”按钮，否则设置的值不成功。**

After the user "logs in" (the default login password of "user" is 0008, and the password can be modified through the login interface), the high temperature alarm value and name of the wireless temperature sensor group can be set through the "parameter setting" menu. When the measured temperature value exceeds the set value, the touch screen will display the alarm and the buzzer will beep, and Chinese and English language switching can be set. **After setting the parameters, be sure to click the "Save Settings" button, otherwise the set value will be lost.**



图 2.2 登录管理界面

Figure 2.2 login management interface

参数设置											
2020-01-19 16:37:48											
节点高温定值设置											
点号	1/2/3	4/5/6	7/8/9	10/11/12	13/14/15	16/17/18	19/20/21	22/23/24	25/26/27	28/29/30	
+0	80℃	80℃	80℃	80℃	80℃	80℃	80℃	80℃	80℃	80℃	
+30	80℃	80℃	80℃	80℃	80℃	80℃	80℃	80℃	80℃	80℃	
+60	80℃	80℃	80℃	80℃	80℃	80℃	80℃	80℃	80℃	80℃	
+90	80℃	80℃	80℃	80℃	80℃	80℃	80℃	80℃	80℃	80℃	
+120	80℃	80℃	80℃	80℃	80℃	80℃	80℃	80℃	80℃	80℃	
+150	80℃	80℃	80℃	80℃	80℃	80℃	80℃	80℃	80℃	80℃	
+180	80℃	80℃	80℃	80℃	80℃	80℃	80℃	80℃	80℃	80℃	
+210	80℃	80℃	80℃	80℃	80℃	80℃	80℃	80℃	80℃	80℃	
设备地址	1										
实时温度							1/3	下一页	保存设置		



图 2.3 参数设置

Figure 2.3 parameter setting

2.3 报警信息

2.3 alarm information

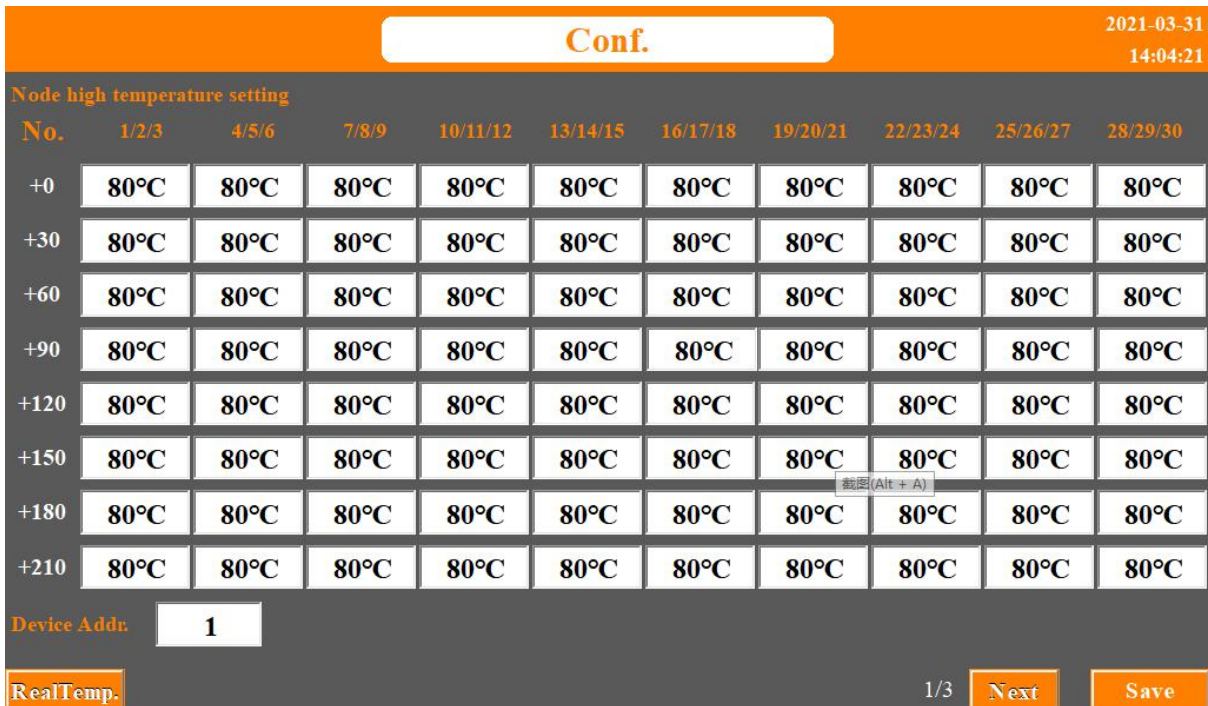
进入“当前报警”界面，显示的是当前告警发生情况，如图 2.4；若要查看所有历史告警，进入“历史报警”界面。在“当前报警”界面查看实时发生的报警，有报警时，此界面显示出报警提示，并且蜂鸣器鸣叫，在蜂鸣器鸣叫时，点击确认报警，蜂鸣器会停止鸣叫，同时报警提示的字颜色会变为蓝色，当报警故障消除后，报警提示会消失。

Enter the "current alarm" interface to display the current alarm occurrence, as shown in Figure 2.4; to view all historical alarms, enter the "historical alarm" interface. Check the real-time alarm in the "current alarm" interface. When alarming, the interface will display the warning tips and the buzzer will beep. When the buzzer beeps, click to confirm the alarm and the buzzer will stop. At the same time, the color of the warning tips will change to blue. When the alarm fault is removed, the warning tips will disappear.



图 2.4 当前报警
Figure 2.4 current alarm

2.4 温度曲线

2.4 temperature curve

进入“温度曲线”界面，每一个页面存有 12 条曲线，共 20 页。每 1 小时记录一次温度，可以存储 100 天。具体曲线要求可在屏上自行调节。

Enter the "temperature curve" interface, each page has 12 curves, a total of 20 pages. The temperature is recorded every hour and can be stored for 100 days. The specific curve requirements can be adjusted on the screen.



图 2.5 温度曲线

图 2.5 temperature curve

3 通讯指南

3 Communication Examples

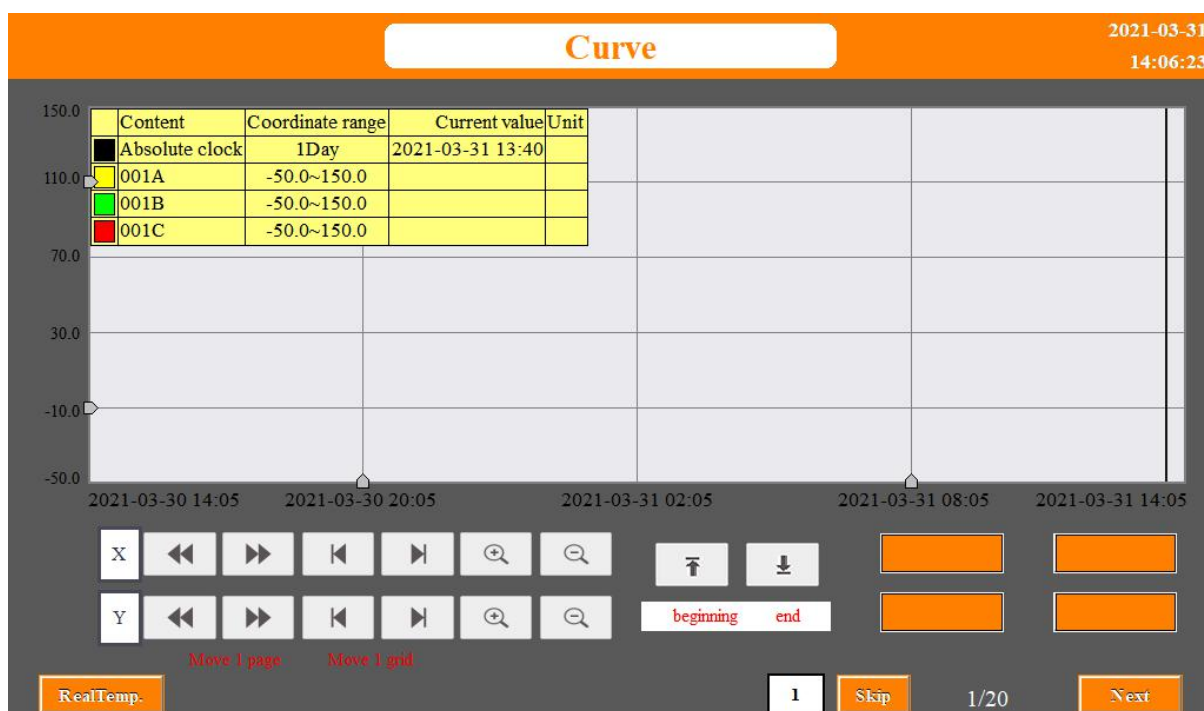
在本章主要讲述如何利用软件通过通讯口来读取无线测温节点温度。本章内容的掌握需要您具有 MODBUS 协议的知识储备并且通读了本册其他章节所有内容，对本产品功能和应用概念有较全面的了解。

In this chapter, we mainly describe how to use software to read the temperature of wireless temperature measurement point through communication port. The master of this chapter requires you to have the knowledge reserve of Modbus protocol and read through all the other chapters of this instructions. You have a comprehensive understanding of the function and application concept of this product.

本章内容包括：通讯应用格式详解，本机的应用细节及参量地址表。

The content of this chapter includes: detailed explanation of communication application format, application details of this machine and parameter address table.

3.1 通讯格式详解

本节所举实例将尽可能的使用如下表所示的格式，数据为十六进制。

The examples in this section will use the format shown in the following table as much as possible, the number is hexadecimal.

3.1.1 读取数据（功能码 04H（只读寄存器）/03H（读写寄存器））

3.1.1 Read State (Function code 04H (Read only register) /03H (Read write register))

此功能允许用户获得设备采集与记录的数据及系统参数。主机一次请求的数据个数没有限制，但不能超出定义的地址范围。

This function allows the user to get the data measured and system parameters recorded by slave. There is no limit of data length for asking data, but it cannot exceed the range of defined address.

例如，主机发送查询数据帧：

For example, master send data frame:

地址 Addr	功能码 Fun	起始地址 Register Addr		寄存器数量 Register Count		CRC16 校验码 CRC 16	
		高 Hi	低 Lo	高 Hi	低 Lo	高 Hi	低 Lo
01H	03H	00H	30H	00H	03H	05H	C4H

装置返回响应数据帧：

Slave answer data frame:

地址 Addr	功能码 Fun	字节数 Byte	数据 1 Data 1	数据 2 Data 2	数据 3 Data 3	CRC16 校验码 CRC 16
------------	------------	-------------	----------------	----------------	----------------	---------------------

		count	高 Hi	低 Lo	高 Hi	低 Lo	高 Hi	低 Lo	高 Hi	低 Lo
01H	03H	06H	00H	00H	00H	00H	00H	00H	21H	75H

3.1.2 预置单个寄存器（功能码 06H）

3.1.3 Preset Single Register (Function code 06H)

此功能码允许用户改变单个寄存器的内容，可通过此功能码将工作参数写入装置。

User can write active parameter into the single register with this function code.

例如，主机发送：

For example, master send data frame:

地址 Addr	功能码 Fun	寄存器地址 Register Addr		预置值 Value		CRC16 校验码 CRC16	
		高 Hi	低 Lo	高 Hi	低 Lo	高 Hi	低 Lo
01H	06H	00H	03H	03H	E8H	74H	79H

装置返回响应数据帧：

Slave answer data frame:

地址 Addr	功能码 Fun	寄存器地址 Register Addr		预置值 Value		CRC16 校验码 CRC 16	
		高 Hi	低 Lo	高 Hi	低 Lo	高 Hi	低 Lo
01H	06H	00H	03H	03H	E8H	74H	79H

3.1.3 预置多个寄存器（功能码 10H）

3.1.3 Preset Multi Registers (Function code 10H)

此功能码允许用户改变多个寄存器的内容，可通过此功能码将工作参数写入装置。

User can write active parameter into the multi registers with this function code.

例如，主机发送：

For example, master send data

地址 Addr	功能码 Fun	起始地址 Register Addr		寄存器数 Register Count		字节数 Byte Count	预置值 1 Value 1		预置值 2 Value 1		CRC16	
		高 Hi	低 Lo	高 Hi	低 Lo		高 Hi	低 Lo	高 Hi	低 Lo	高 Hi	低 Lo
01H	10H	00H	03H	00H	02H	04H	00H	28H	00H	64H	59H	32H

装置返回响应数据帧：

Slave answer data frame:

地址 Addr	功能码 Fun	起始地址 Register Addr		寄存器数量 Register Count		CRC16 校验码 CRC16	
------------	------------	-----------------------	--	-------------------------	--	--------------------	--

		高字节 Hi	低字节 Lo	高字节 Hi	低字节 Lo	高字节 Hi	低字节 Lo
01H	10H	00H	03H	00H	02H	B1H	C8H

3.2 通讯地址表

3.2 Communication address list

地址 Addr	参数 Parameter	属性 Attribute	数值范围 Range	数据类型 Data type
0000H	通讯地址 Addr	R/W	001~247	UWord
0001H	预留 Reserved	R		UWord
0002H	告警状态 Alarm status	R	0, 无温度越线; 1, 温度越线告警。 0, No temperature over; 1, Temperature over line alarm.	UWord
0003H	收发器环境温度 Transceiver ambient temperature	R	-50~85(°C) (×10 整数传输) -50~85(°C) (× 10 integer transmission)	Word
0004H 00F3H	传感器温度值 Sensor temperature value	R	-50~125(°C), (×10 整数传输), 共 240 个 -50~125(°C)(× 10 integer transmission), 240 in total	Word
00F4H 01E3H	传感器 ID sensor ID	R	每个传感器的 ID 应该不同, 共 240 个 Each sensor ID should be different, 240 in total	UWord
01E4H 01F2H	无线温度传感器 在线状态 Online status of wireless temperature sensor	R	位数据, bit0~bit239 分别对应 1~240 号传感器 在线状态; 0——离线, 1——在线。 Bit data, bit0 ~ bit239 correspond to the online status of sensors 1 ~ 240 respectively; 0 - offline, 1 - online.	UWord
01F3H 0201H	无线温度传感器 电池状态 Wireless temperature sensor battery status	R	位数据, bit0~bit239 分别对应 1~240 号传感器 电池状态; 0——正常, 1——低压。 Bit data, bit0 ~ bit239 correspond to the battery status of sensors 1 ~ 240 respectively; 0 - normal, 1 - low voltage.	UWord
0202H 0251H	无线温度传感器高 温定值 Wireless temperature sensor temperature value	R/W	-50~125(°C), 共 80 个(每个定值对应 3 路传感器) -50~125 (°C), a total of 80 (each constant value corresponds to 3 sensors)	Word

注: [1] R—只读; R/W—可读, 可写。

Note: [1] r-read-only; R / w-read-write.

3.3 通讯设置

3.3 communication settings

如需所有数据传入后台监控系统,则要设置正确的通讯地址,默认通讯地址为 1,波特率为 9600,通讯地址的设定在“参数设置界”面中,在“转发数据地址”输入框内,修改成相应的地址,然后点击“保存设置”,否则掉电后会恢复到默认地址 1。

If you need all the data to be transferred into the background monitoring system, you need to set the correct communication address. The default communication address is 1, and the baud rate is 9600. The communication address is set in the "parameter setting interface". In the "forward data address" input box, modify it to the corresponding address, and then click "Save Settings". Otherwise, it will return to the default address 1 after power failure.

总部：安科瑞电气股份有限公司

Headquarter: Acrel Co., LTD.

地址：上海市嘉定区育绿路 253 号

Address: No.253 Yulv Road Jiading District, Shanghai, China.

电话：0086-21-69158300 0086-21-69156052 0086-21-59156392 0086-21-69156971

TEL.: 0086-21-69158300 0086-21-69156052 0086-21-59156392 0086-21-69156971

传真：0086-21-69158303

Fax: 0086-21-69158303

网址：www.acrel-electric.com

Web-site: www.acrel-electric.com

邮箱：ACREL008@vip.163.com

Email: ACREL008@vip.163.com

邮编：201801

Postcode: 201801

生产基地：江苏安科瑞电器制造有限公司

Manufacturer: Jiangsu Acrel Electrical Manufacturing Co., LTD.

地址：江苏省江阴市南闸街道东盟工业园区东盟路 5 号

Address: No.5 Dongmeng Road Dongmeng Industrial Park, Nanzha Street, Jiangyin

电话（传真）：0086-510-86179970

TEL./Fax: 0086-510-86179970

网址：www.jsacrel.com

Web-site: www.jsacrel.com

邮箱：JY-ACREL001@vip.163.com

Email: JY-ACREL001@vip.163.com

邮编：214405

Postcode: 214405